



---

## Instruction Manual

---

### Neutron survey meter

NSN31047 - YYYYY-S

NSN31047 - YY1YY-S

NSN31047 - Y1YYY-S

NSN31047 - Y11YY-S

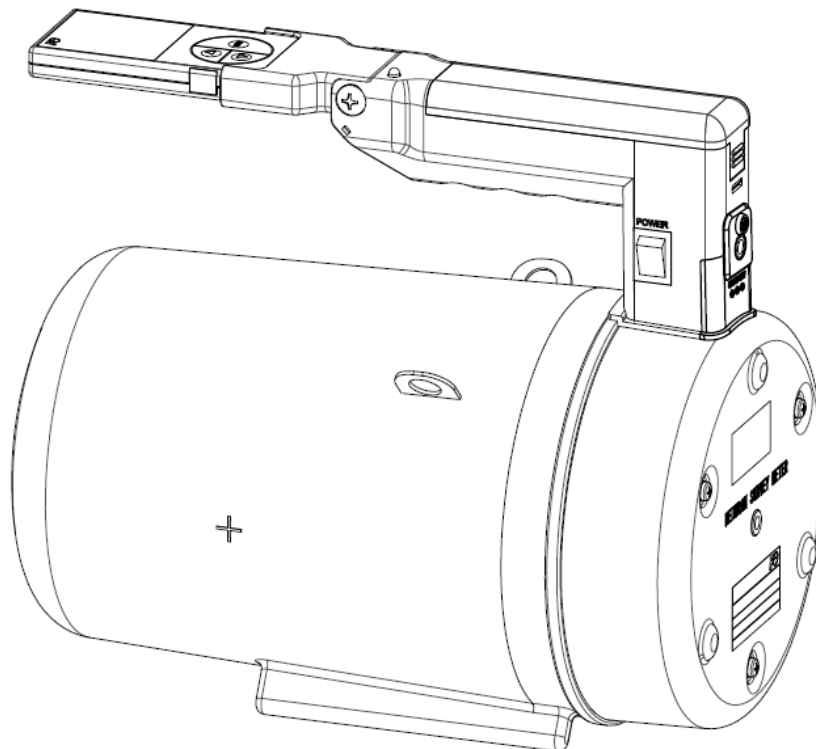

Nov. 2024

## FOREWORD

Thank you for purchasing the FUJI ELECTRIC's **NSN3** neutron survey meter. This manual describes the operation, features and parts of the survey meter. Please read the manual carefully to ensure the correct operation before use.

In case of a product failure, please contact our sales representative or agency with detailed information including the instrument status, problem specification, model and product serial number. Please enclose any pictures or diagrams in order to facilitate our understanding of the problem.

The unauthorized user, repairing or modifying may result in electrical shock hazards, incorrect operation and may void warranty. FUJI ELECTRIC will not be responsible for any deaths and injuries sustained due to the unauthorized repair.

## Product Package Contents

This package contains the items listed in the table below. Please confirm before use.

Item	Quantity	Remarks
<b>NSN3</b> Neutron survey meter	1	One USB connector Includes a button-type battery
Instruction manual	1	This document
Test report	1	
AA alkaline batteries	6	
Shoulder belt	1	

## Optional Accessories

The following optional accessories are available.

Please contact our sales representative or agency.

Item	Quantity	Remarks
AC adapter	1	12V DC
AA Ni-MH rechargeable batteries	6	BK-3MCC/2C (3 packs)
Battery charger	1	K-KJ85MCC40
Maintenance software	1	Includes USB cable and manual
Fiberboard box for transportation	1	590mm(L) x 390mm(W) x 310mm(H) Includes inner materials
Transportation case	1	Pelican 1600 Includes inner materials

# For Your Safety

Read the following safety precautions in order to use the product safely and prevent personal injury and product damage. Read the complete Instruction Manual for further information before using the product. Please note that the contents of this Manual may change due to the product modification without notice.

	Safety Precautions
 <b>Attention</b>	<ul style="list-style-type: none"><li>- The <b>NSN3</b> is a precision instrument and should be handled with care.</li><li>- Do not drop or subject the survey meter to impact.</li><li>- Keep the instrument in a plastic bag for protection against organic solvents, water droplets, moisture, dust and contamination.</li><li>- The instrument should always be handled with clean, dry hands.</li><li>- If it is contaminated with dirt, clean the survey meter by wiping it with a dry cloth.</li><li>- Do not use the survey meter in an environment with high-frequency noise.</li><li>- Pay careful attention when using it near the following devices:<ol style="list-style-type: none"><li>1. Cell phones (aka. Mobile phones)</li><li>2. Smart phones (i.e. iPhone, BlackBerry, etc.)</li><li>3. PHS handsets</li><li>4. High power transceivers (or similar devices)</li><li>5. Microwave ovens</li><li>6. Radars</li><li>7. Welding machines</li><li>8. Any other spark discharging or high-intensity, radio-wave emitting devices</li></ol></li></ul> <p>(Note: Keep the instrument at least 50 cm away from the PHS terminals, cell phones and smart phones.)</p>

	Safety Precautions
 <b>Attention</b>	<ul style="list-style-type: none"> <li>- When the "low battery" indicator appears, replace old batteries with the new ones immediately. If you are using Ni-MH rechargeable batteries, remove and recharge the batteries with the designated charger. Replace the batteries when they are fully charged.</li> <li>- Replace primary batteries with standard AA alkaline batteries.</li> <li>- To prevent short outs, protect exposed terminals with insulating tape prior to disposal. Failure to do so may cause excessive heat generation, rupturing or combustion leading to personal death, injury and fire.</li> <li>- Safely dispose of used batteries by following the instructions at your local government.</li> <li>- For secondary batteries, use the standard Ni-MH rechargeable batteries.</li> <li>- Do not mix the battery types (the standard AA alkaline with Ni-MH batteries).</li> <li>- Do not throw the instrument or batteries into the fire.</li> <li>- Do not disassemble the instrument.</li> <li>- For the survey meter disposal, please contact our sales representative or agency.</li> </ul>

# Material Safety

The **NSN3** detector of contains flammable gas. Follow the attentions below.



## Attention

- Flammable gas is used in the detector.
- Do not use the product near fire.
- Do not throw the product into an open fire.
- Do not expose the product to shock or impact.
- Do not drop the survey meter. As this will damage the detector and flammable gas may leak, leading to fire or explosion.
- If you have any questions, contact our sales representative or agency.

The **NSN3** does not contain harmful substances.

- RoHS (2011/65/EU)

# Disposal of Electronic Equipment

Dispose this product as an industrial waste.

Always follow the instructions at your local government regarding waste disposal.

If you have question, contact our representative or agency.

# Contents

1. General .....	8
2. Product type code.....	8
3. Specifications.....	9
4. Parts and features .....	11
4.1 Configuration.....	11
4.2 Display unit.....	14
4.3 Description of the displays .....	16
5. Operation .....	18
5.1 Dose rate measurement and time constant setting.....	23
5.2 Accumulated dose measurement .....	25
5.3 Time setting (Accumulation) .....	28
5.4 Backlight setting (Power-Saving mode).....	30
5.5 Buzzer (monitoring sound).....	33
5.6 Trend data storage cycle.....	35
5.7 Date & time setting.....	38
5.8 Copy of trend data.....	41
5.9 Maintenance.....	44
6. Maintenance .....	46
6.1 Maintenance and inspection procedures .....	46
6.2 Replacement parts .....	48
6.3 Battery replacement.....	49
6.4 Handle replacement.....	50
7. Time constant table .....	54
8. Troubleshooting .....	55
9. Appendix A     Characteristic for neutrons and gamma-rays.....	57
9.1 Relative error of indication .....	57
9.2 Energy characteristics.....	58
9.3 Response for photon radiation.....	60
9.4 Angular dependence .....	60
10. Appendix B    Error code .....	61
11. Appendix C    Confirmation of dose rate response .....	62
12. Appendix D    Transportation.....	67
12.1 Packing method .....	68
12.2 Transportation method .....	71
12.3 Special permit .....	72

## 1. General

This equipment is the portable neutron survey meter, to measure the neutron dose rate and the accumulated dose at neutron fields in nuclear facilities or accelerator facilities. Lightweight and high sensitivity have been achieved by adopting the organic mixed gas counter.

The measurement values are displayed on the screen. In addition, the count monitor beeps and the LED flashes indicating counting activity.

The **NSN3** operates on six standard AA alkaline or the optional AA Ni-MH rechargeable batteries. An AC adapter is also available as an option.

By using the USB connector, the data can be transmitted to the PC and the real time dose rate and accumulated dose are displayed on the PC by utilizing the optional maintenance software.

## 2. Product type code

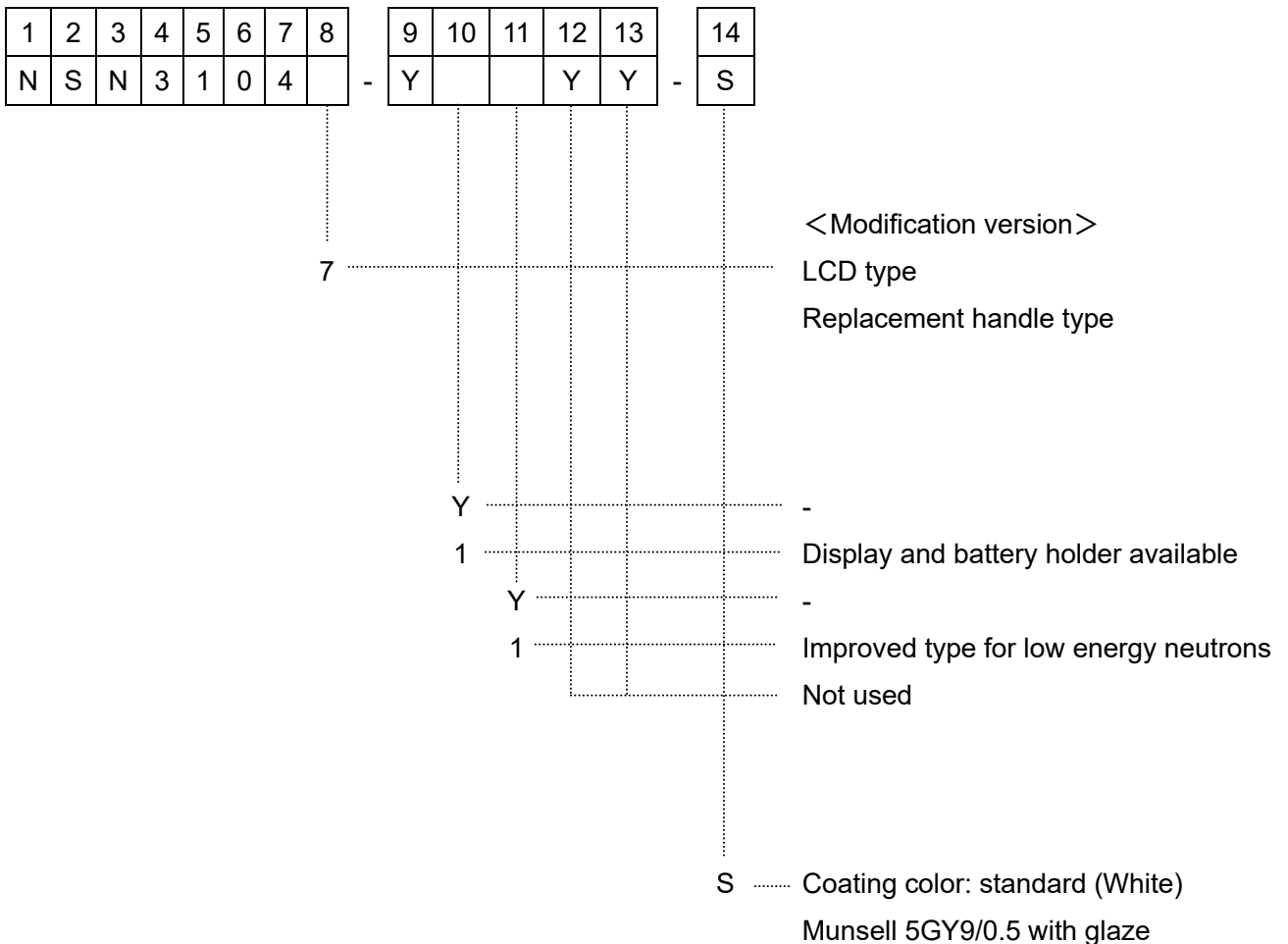

### 3. Specifications

No.	Item	Specification
1	Radiation detected	Neutron (Excluding pulsed neutron)
2	Energy range	0.025eV to 15MeV
3	Detector	Organic mixed gas counter
4	Moderator	NSN31047-YYYYY-S : Not used NSN31047-Y1YYY-S : Not used NSN31047-YY1YY-S : Polyethylene NSN31047-Y11YY-S : Polyethylene
5	1cm dose equivalent rate Effective measurement range	5 decades 1 $\mu\text{Sv h}^{-1}$ to 99.99 $\text{mSv h}^{-1}$
6	1cm dose equivalent Effective measurement range	6 decades 0.1 $\mu\text{Sv}$ to 99.99 $\text{mSv}$
7	Measurement accuracy (for dose rate)	$\pm 20\%$ or less at 10 $\mu\text{Sv h}^{-1}$
8	Measurement accuracy (for accumulate dose)	$\pm 20\%$ or less at 1 $\mu\text{Sv}$
9	Energy dependency	Compliance with response curve of ICRP pub. 74 H*(10)
10	Angular dependence	$\pm 25\%$ (0 deg. to $\pm 90$ deg., $^{252}\text{Cf}$ or Am-Be)
11	Dose rate characteristic	$\pm 20\%$ (ref. 10 $\mu\text{Sv h}^{-1}$ )
12	Gamma ray sensitivity	Up to 10 $\text{mSv h}^{-1}$ : 1 % or less for $^{137}\text{Cs}$
13	Time constant switching	Selectable from "Long(L)" "Medium(M)" "Short(S)" "Auto(A)". Time constant is also selectable depending on dose rate
14	Measurement range switching	Automatic switching ( $\mu\text{Sv h}^{-1} \leftrightarrow \text{mSv h}^{-1}$ )
15	Display	LCD type (NHV10043)
16	Indicator	Maximum 5 decades Dose rate : 0.00~999.99 $\mu\text{Sv h}^{-1}$ 1.00~99.99 $\text{mSv h}^{-1}$ Accumulate dose : 0.00~999.99 $\mu\text{Sv}$ 1.00~99.99 $\text{mSv}$
17	Preset time for continuous measurement of accumulated dose	Settable from 1 to 9999 min in steps of 1 min.
18	Trend data function	<ul style="list-style-type: none"> <li>• Automatic storage of dose rate at fixed time interval (up to 1200 data)</li> <li>• Time intervals of 0sec, 10sec, 20sec, 30sec, 1min, 2min, 5min and 10min are available. Default setting is 5 min. (If 0sec is selected, this trend data storage is not working.)</li> <li>• Recording items : Serial No., Measured day/time, dose rate, Accum. dose, unit, Time intervals (period), counts, battery voltage, high voltage setting value (For change of time intervals for recording and readout of trend data, "Communication software (another sale)" is needed.)</li> </ul>
19	PC connection	Serial data communication using USB port

No.	Item	Specification
20	Power source	(1) Primary battery (6 ordinary AA alkaline batteries) (2) Secondary battery (6 ordinary AA Ni-MH batteries) (3) Commercial AC source (with AC adaptor)
21	Monitor beep	ON / OFF
22	Check functions	(1) Battery level  AC adaptor  Battery level 4 : Ample charge.  Battery level 3 : Medium charge.  Battery level 2 : Low charge.  Battery level 1 : Battery level very low. <p style="text-align: right;">Charge the battery in the 30 min.</p>  Battery level 0 : Battery level zero. <p style="text-align: right;">Change the battery.</p> (2) High dose rate Blink 99.99
23	Battery life	12 hr or more
24	Operating temperature	-10 to + 45 deg
25	Operating humidity	35 % to 90 % (non-condensing)
26	Power consumption	Typ. 80mA
27	Size	W150mm x H250mm x L300mm
28	Mass	NSN31047-YYYYY-S : 2.5 kg approx. NSN31047-Y1YYY-S : 2.5 kg approx. NSN31047-YY1YY-S : 3.5 kg approx. NSN31047-Y11YY-S : 3.5 kg approx.
29	Warranty period	1 year from purchase date unless warranty period is agreed on the contract.
30	Life	10 years approx. (operation at background level)
31	Accessories	- Instruction manual (TN5A2571) ..... 1 - Test report ..... 1 - AA alkaline batteries ..... 6 - Shoulder belt..... 1
32	Option (Another sales)	Please contact our sales representative or agency for the details. - AC adaptor (100 to 240V AC, 12V DC) : LTE65ES-S2 conversion plug : TR-AD4W - AA Ni-MH rechargeable batteries : BK-3MCC/2C (3packs) - Charger for AA Ni-MH rechargeable batteries : K-KJ85MCC40 - Maintenance software : TQ504309P24 - USB cable (A-minB) : TQ504315P1 - Transportation case : Pelican 1600 - Fiberboard box for transportation : 590mm(L)x390mm(W)x310mm(H)

## 4. Parts and features

This Section describes parts and features of the **NSN3**.

### 4.1 Configuration

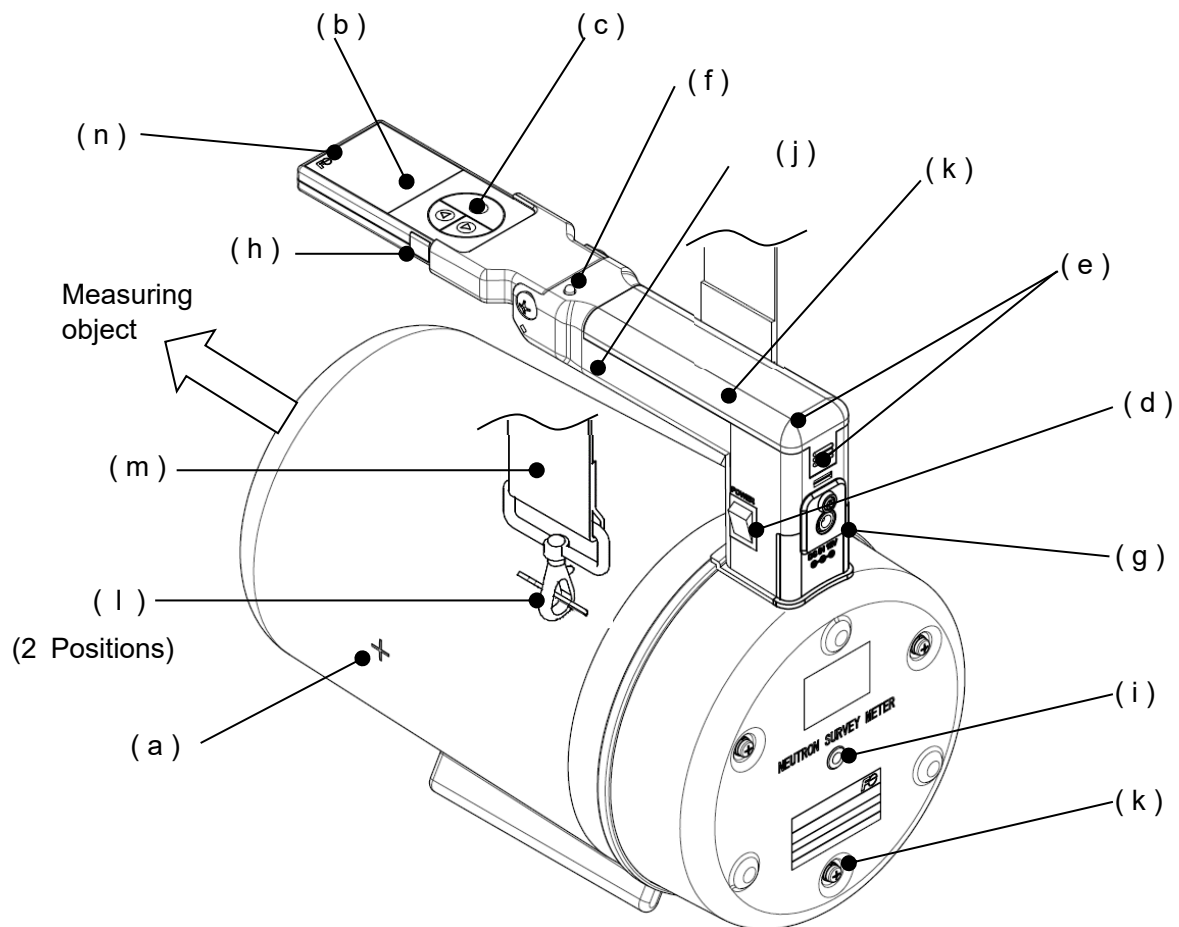

#### (a) Detector body

Detects neutrons. Point the detector to the object to be measured.

#### (b) Display

The organic electroluminescence display screen displays measurement values and various status.

 <b>Attention</b>	Always turn OFF the <b>NSN3</b> before inserting or extracting the Display Unit to avoid incorrect operation.
---	---

### (c) Operating pad

Use the operating pad to switch between various functions. Refer to the section 4.3 for details on display unit.

### (d) Power switch

Press down the “|” to turn ON.

Press down the “O” to turn OFF.

### (e) Battery compartment

Pressing down on point A, slide the battery cover upward (in the direction indicated by the arrow) to remove the cover.

In case of NSN31047-Y11YY-S and NSN31047-Y1YYY-S, loosen the screw at point B by hand.

Insert six batteries according to the polarity (+,-) marks inside the Battery compartment. Refer to the section 6.3 for details on "Battery replacement".

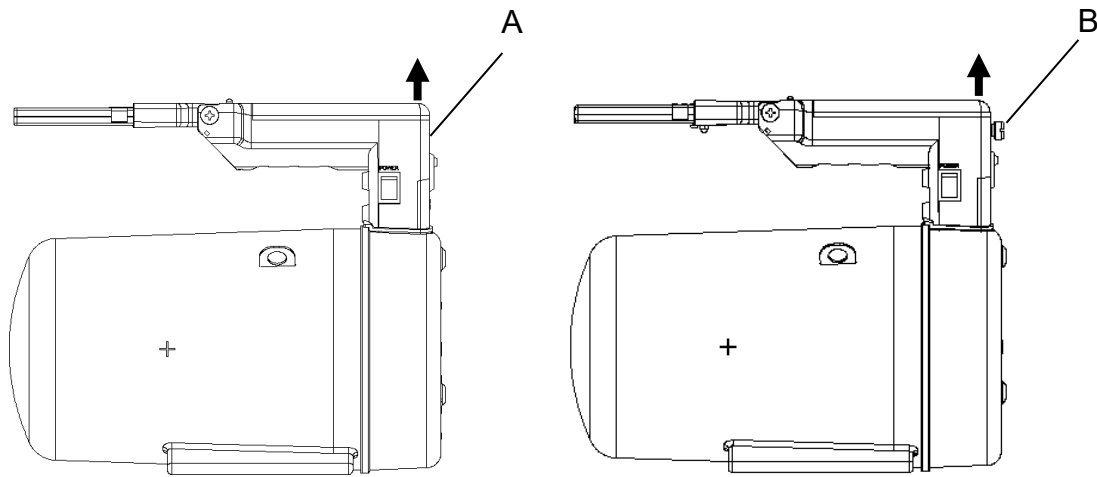

NSN31047-YYYYY-S

NSN31047-YY1YY-S

NSN31047-Y11YY-S

NSN31047-Y1YYY-S



#### Attention

- Always turn OFF the **NSN3** before replacing batteries.
- Insert new batteries, observing the polarity marks (+/-) inside the battery compartment.
- Use only standard AA alkaline batteries or Ni-MH rechargeable batteries.
- When replacing batteries with standard AA alkaline batteries, use six new batteries.
- When replacing the AA Ni-MH rechargeable batteries, use six fully recharged batteries.
- Always follow the instructions at your local government when disposing the used batteries.

**(f) LED (Red)**

- Flashes in response to detection count. The light is continuously on when a high dose rate is detected.

**(g) Power jack**

- Use only FUJI ELECTRIC approved AC adapter (optional) designated for the **NSN3**. Failure to do this may result in a malfunction or excessive heat generation.

 <p><b>Attention</b></p>	<p>Use only the designated charger for recharging AA Ni-MH batteries. When recharging Ni-MH batteries, open the battery cover and remove all the batteries.</p> <p>Refer to the section 6.3 for details on the "Battery replacement".</p>
---	---

**(h) USB connector**

- The USB connector is used for data transfer. Remove the protecting rubber cover and attach the optional USB cable to connect the **NSN3** to the PC. Do not touch the USB connector as dirt or dust could cause transmission failure. Replace the rubber cover when not in use to protect the connector from dust and water.

**(i) Tapped hole for tripod**

- Screw a commercially available camera tripod into.

**(j) Handle**

- Use the handle for hand carry.

**(k) Screw for fastening case cap**

- Unscrew only at the time of maintenance. Do not open the case unnecessarily. The penetration of foreign materials or water into internal circuit may cause malfunction.

**(l) Shoulder belt clasps**

- Use the Belt Clasps to join the ends of the Shoulder Belt to the **NSN3** at 2 points.

**(m) Shoulder belt**

- At the time of carrying the survey meter, attach the Belt to the **NSN3** with its clasps. refer to (l).

**(n) Display holder**

- For display drop prevention at type of NSN31047-Y11YY-S and NSN31047-Y1YYY-S.

## 4.2 Display unit

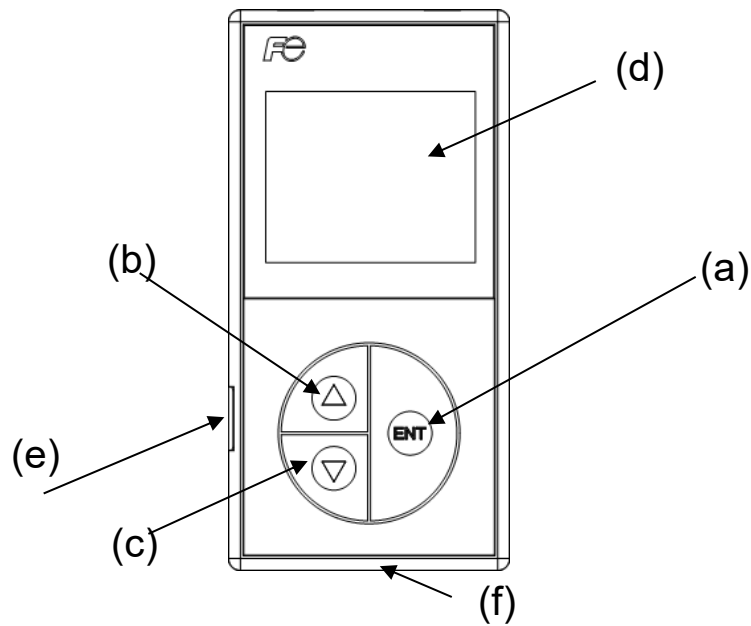

### (a) ENT key

- Use the "ENT" key to display setup values/setup screen while the dose rate is displayed.
- The "ENT" key is also used to cancel or confirm various parameters.

### (b) Δ key

- Use the "Δ" key to move the cursor up to the next selection. The "Δ" key is also used to START, STOP, or RESET the accumulation process in the accumulation mode.
- By pressing the "Δ" key in the measurement mode, each display is shown in the following order:

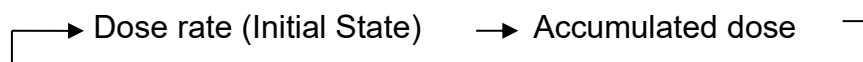

### (c) ▽ key

- Use the "▽" key to move the cursor down to the next selection. The "▽" key is also used to START, STOP, or RESET the accumulation process in the accumulation mode.
- By pressing the "▽" key in the measurement mode, each display is shown in the following order:

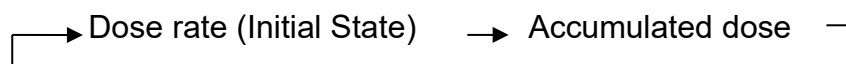

**(d) Display**

- The organic electroluminescence display screen displays the measurement values and the various statuses.

**(e) USB connector**

- The **NSN3** can be connected to the PC by attaching the optional USB cable to the connector. remove the protective rubber cover and then attach the cable.
- The optional maintenance software is required for the data communication with the PC.

**(f) Communication connector**

- Use the connector to connect the display unit to the main body.

## 4.3 Description of the displays

### 4.3.1 Display (Dose rate)

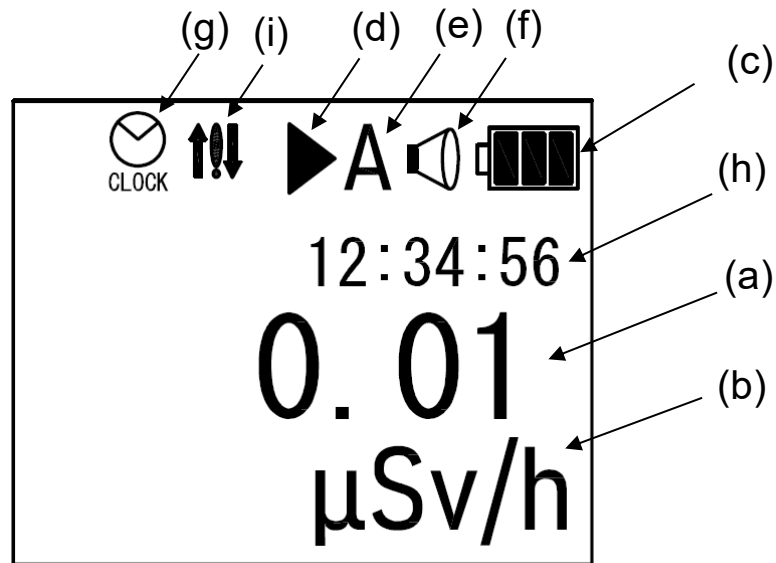

**(a) Dose rate value**

- Displays Dose Rate Value in digital format.

**(b) Unit**

- Displays selected unit: " $\mu\text{Sv/h}$ " or " $\text{mSv/h}$ ".

**(c) Battery Indicator**

- Indicates the battery level. Replace the standard AA alkaline batteries immediately when the " " indicator appears, indicating that the battery level is low. When using Ni-MH rechargeable batteries, recharge the batteries with the designated charger (optional). Refer to the section 6.3 for details on the "Battery replacement" when replacing AA alkaline batteries or recharging Ni-MH batteries.

**(d) Accumulated dose mark**

- Indicates that the **NSN3** is accumulating dose values. When dose values are not being accumulated, "||" is displayed.

**(e) Time constant**

- Indicates selected time constant: A, L, M, or S. Refer to section 5.1 for Time constant setting and the section 7 for details on the "Time constant".

**(f) Buzzer indicator**

- Indicates whether the count monitoring sound is ON/OFF.

**(g) Clock display**

- Indicates that time display (clock) is displayed at position (h).

**(h) Time display (clock)**

- Displays the current time (Hours: Minutes: Seconds).

**(i) Communication error**

- Indicates communication error between the display and the detector board. Refer to the section 10 for details on the "Error code".

### 4.3.2 Display (Accumulated dose)

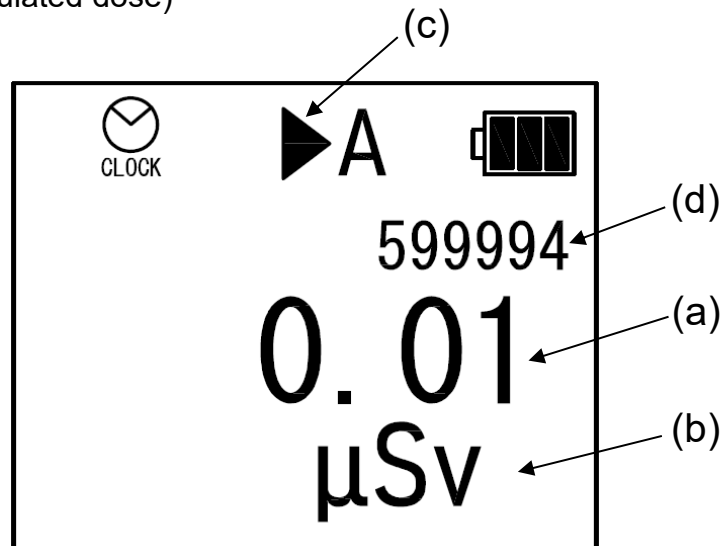

**(a) Accumulated dose**

- Displays accumulated dose value in digital format.

**(b) Unit**

- Displays selected unit: "μSv" or "mSv".

**(c) Accumulation indicator**

- Indicates that the **NSN3** is accumulating the dose values. When the dose values are not being accumulated, "||" is displayed.

**(d) Time display (Remaining time in seconds)**

- Displays remaining measurement time. Refer to the section 5.3 "Time setting (Accumulation)" for details on the "Accum. time".

### 4.3.3 USB cable connection

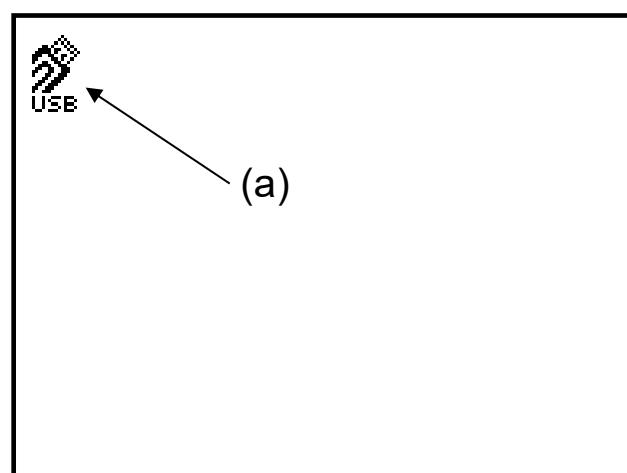

**(a) USB cable indicator**

- Indicates that the display unit is connected to the PC using the USB connector.

## 5. Operation

The operational flow of the **NSN3** is as follows:

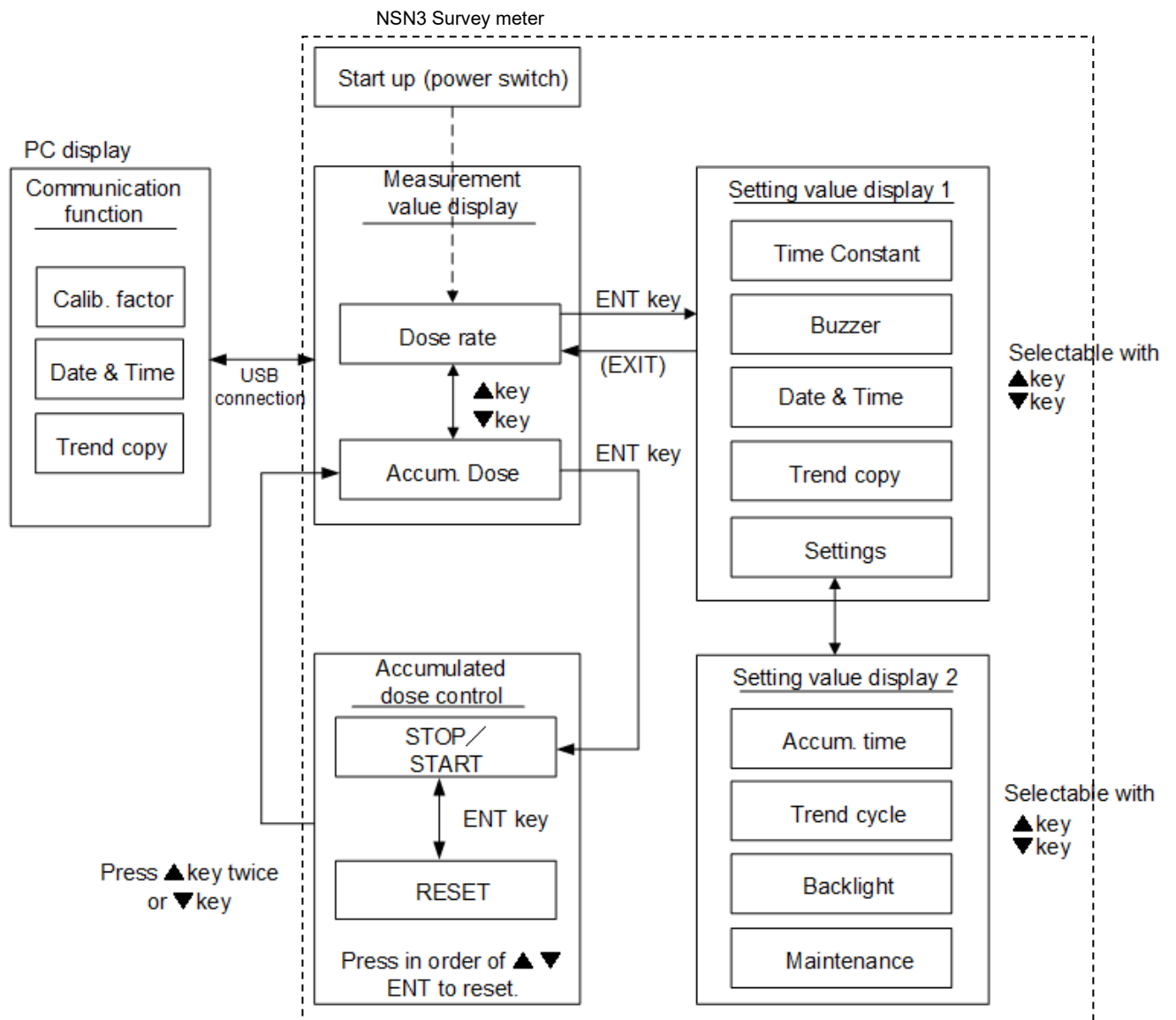

NOTE: When the **NSN3** operates in the measurement mode, the following values can be measured.

Dose rate and accumulated dose, while the data is being transferred to the PC using the USB connector or while trend data is being copied to the display unit Memory, the above data cannot be measured.

The **NSN3** operates in the following four modes:

- Measurement mode      —→ (1)
- Configuration mode    —→ (2)
- Communication mode    —→ (3)
- Accumulation mode     —→ (4)

### (1) Measurement mode

In the measurement mode, the **NSN3** continuously measures the dose rate.

In addition, the **NSN3** displays the followings:

- Dose rate
- Accumulated dose

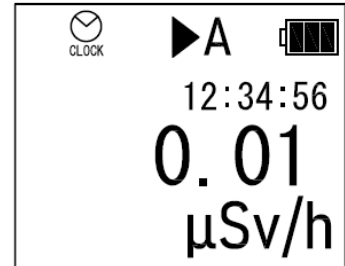

Display sample of measurement mode

### (2) Configuration mode

Parameters such as calibration constant, time constant, buzzer ON/OFF, date and time, copying of the trend data (\*), time (Accumulation), trend data storage cycle, and display brightness can be changed in this Mode.

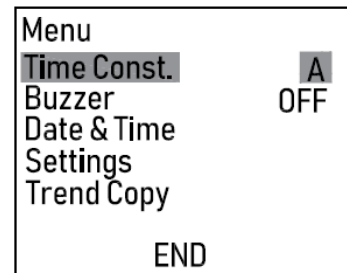

Display sample of configuration mode

**Note (\*):** The latest trend data is copied from the main body into the built-in memory of the display unit.

### (3) Communication mode

This function automatically begins when connecting the survey meter to the PC. The setting values displayed on the PC screen can be changed and the transferred trend data (\*) can be saved in the PC.

**Note (\*):** The updated trend data is transmitted from the main body to the PC. When the main body is turned OFF or the display unit is removed from the main body, the data recorded in the display unit memory is transferred to the PC.

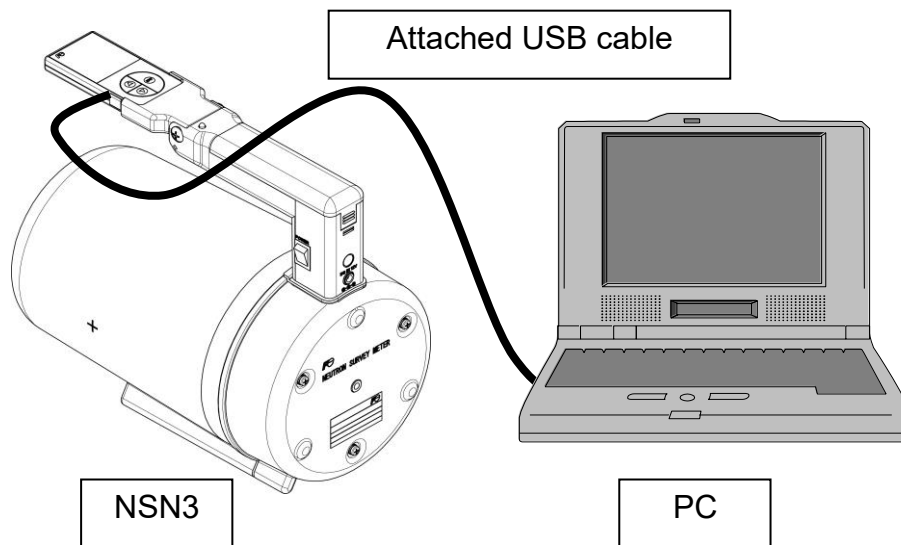

System configuration for the data transfer

### 4) Accumulation mode

- Press the "△" key or the "▽" key to switch between the screens of the dose rate and the accumulated dose

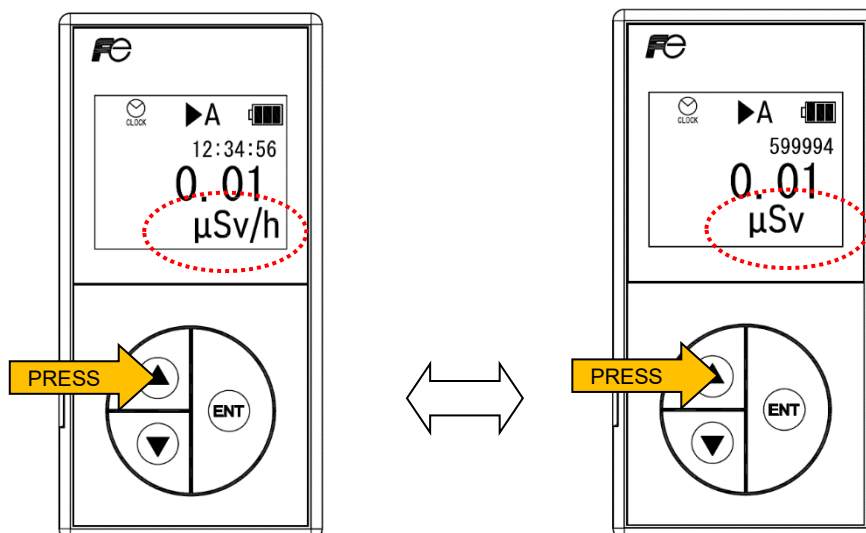

Switching between the dose rate screen and the accumulated dose screen

- Start, stop or reset the accumulation process by pressing the "ENT" key to select "START", "STOP" or "RESET?".

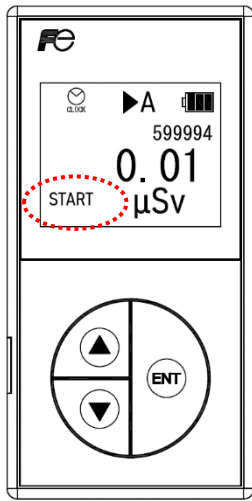

Selecting the "START"

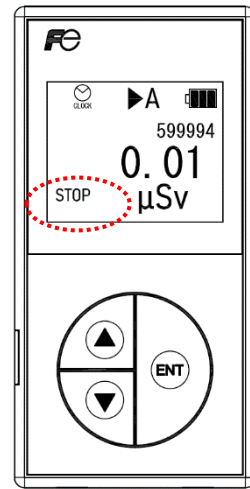

Selecting the "STOP"

Press the "ENT" key.

While the accumulation process has not been performed or stopped, either of the "START" or the "RESET?" appears on the screen by pressing the "ENT" key.

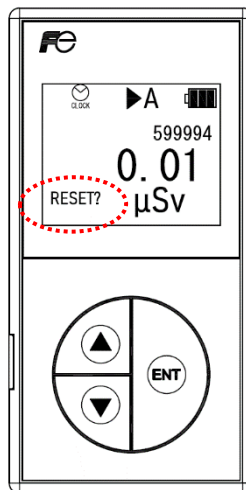

Selecting the "RESET?"

Press the "ENT" key.

While the accumulation process has been performed, either of the "STOP" or the "RESET?" appears on the screen by pressing the "ENT" key.

- To set the selection, press the keys in the order of "△", "▽" and "ENT".

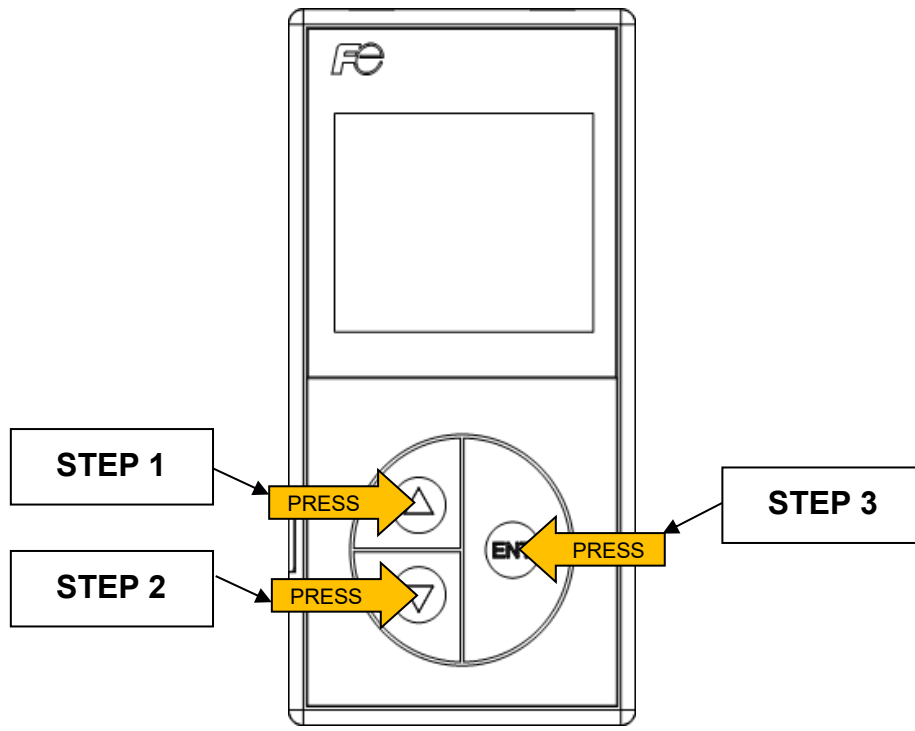

Setting the Selection

When restarting the Accumulation Process, perform the aforementioned procedures.

## 5.1 Dose rate measurement and time constant setting

The dose rate measurement is a basic function of the **NSN3**. By turning on the instrument, the dose rate measurement begins in the measurement mode.

- It takes approximately two seconds for the survey meter to power up. Once the survey meter is ready, the display lights up.
- If more accurate dose rates are required, allow the survey meter to be stable for 3 times the specified time constant and then check the reading. Refer to the section 7 for the details on the "Time constant".
- At the time of Start-Up, the previous buzzer setup (ON/OFF) remains the same.
- In order to set the other parameters, while in the dose rate screen, press the "ENT" key until the "Menu" is displayed.

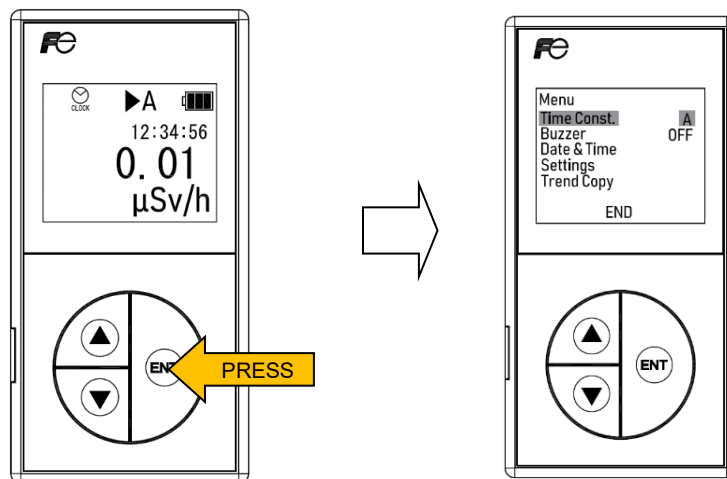

Switching to the "Menu" screen

- To set the time constant:
  - Press the " $\Delta$ " key or the " $\nabla$ " key to select the "Time Const." under the "Menu".

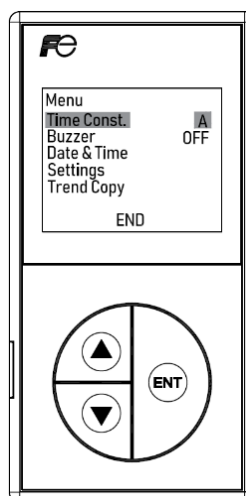

Selecting the "Time Const."

- Press the "ENT" key to select "S", "M", "L" or "A". This will automatically confirm the selection. Refer to the section 7 for details on the "Time constant".

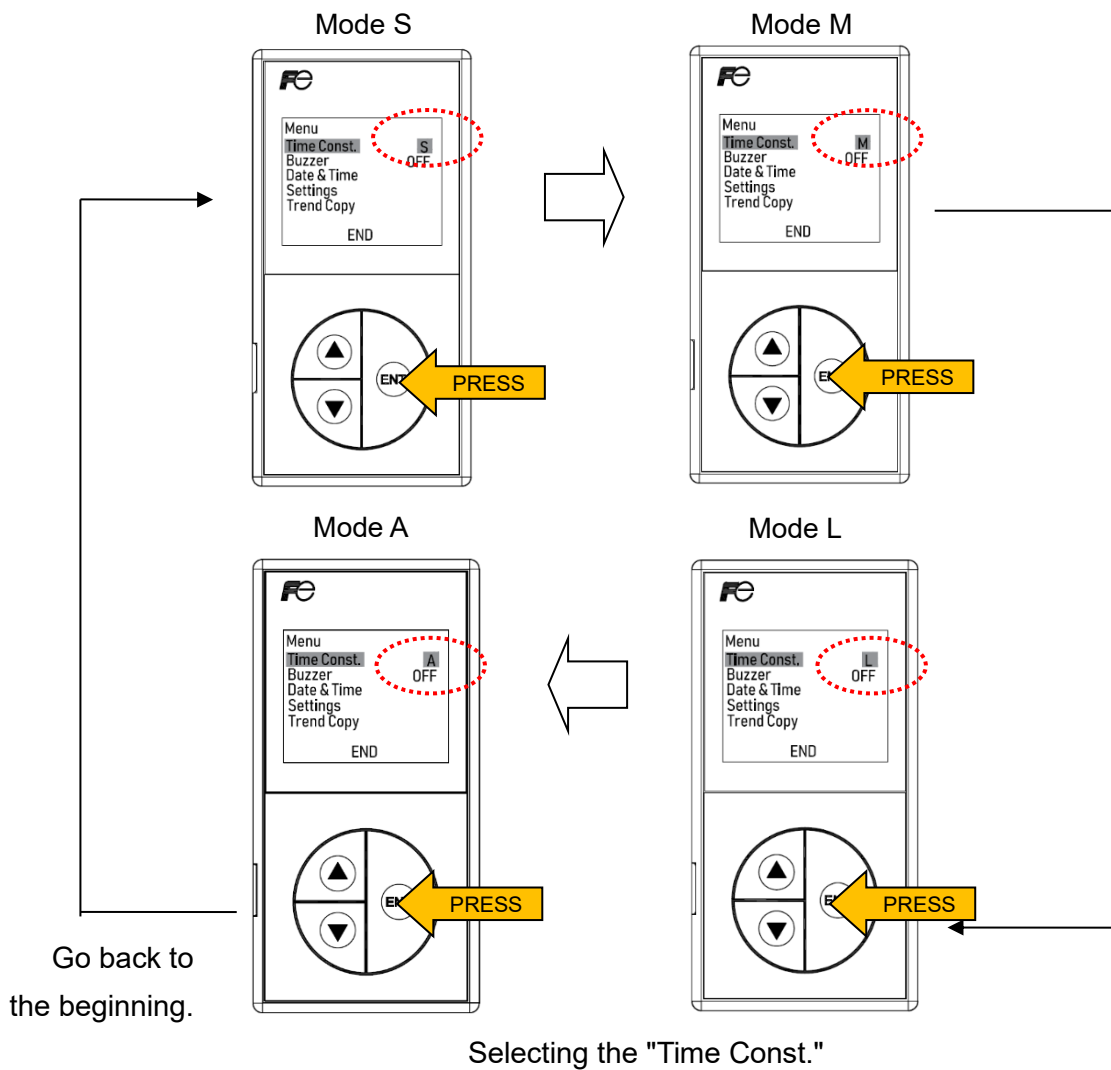

- To display the dose rate screen, press the " $\Delta$ " key or the " $\nabla$ " key to select "END" at the bottom of the screen and then press the "ENT" key.

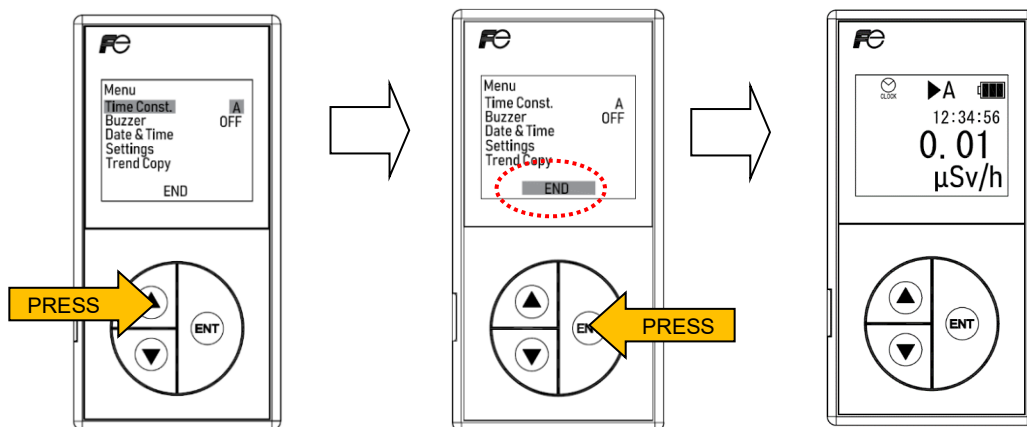

Displaying the dose rate screen

## 5.2 Accumulated dose measurement

Once the switch of the **NSN3** is turned ON, the dose rate screen will be shown.

Then press either the " $\Delta$ " key or the " $\nabla$ " key. It would appear the accumulated dose screen.

The accumulation process will start automatically.

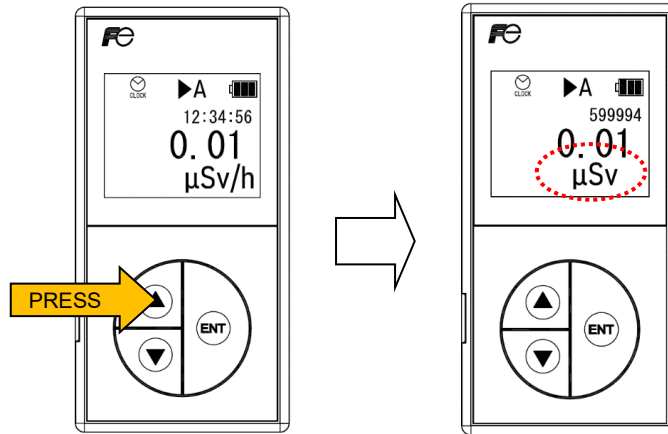

Displaying the accumulated dose screen

- To stop the accumulation process:

- Press the "ENT" key during the accumulation process and then confirm that "STOP" appears in the lower left corner of the screen.

- Press the keys in the order of " $\Delta$ ", " $\nabla$ ", and "ENT".

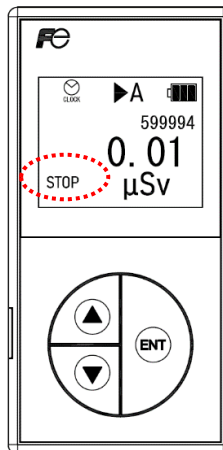

Selecting the "STOP"

- To restart the accumulation process:
  - Press the "ENT" key and then confirm that "START" appears in the lower left corner of the screen.
  - Press the keys in the order of "△", "▽", and "ENT".

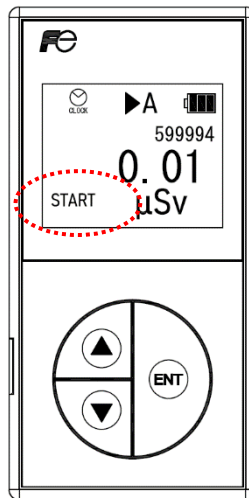

Selecting the "START"

- To reset the accumulation process:
  - Press the "ENT" key twice during the accumulation process then confirm that "RESET?" appears in the lower left corner of the screen.

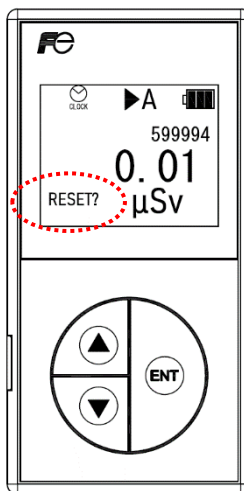

Selecting the "RESET?"

- Press the keys in the order of "△", "▽", and "ENT".  
The accumulated dose and the remaining time are reset.

- To start the accumulation process of dose values:
  - Press the "ENT" key and then confirm that "START" appears in the lower left corner of the screen.
  - Press the keys in the order of "  $\Delta$  ", "  $\nabla$  ", and "ENT".

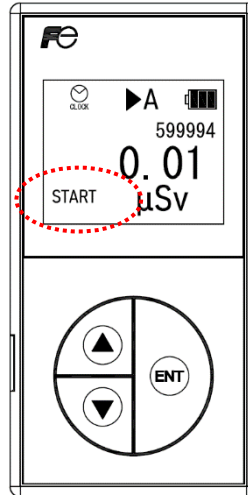

Selecting the "START"

### 5.3 Time setting (Accumulation)

- To display the "Menu", press the "ENT" key while in the dose rate screen shown.

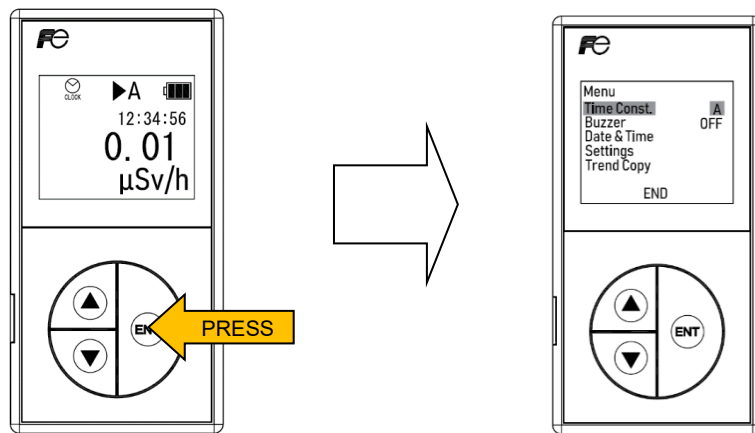

Displaying the "Menu" screen

- Press the "△" key or the "▽" key to select the "Settings" under the "Menu" and then press the "ENT" key.

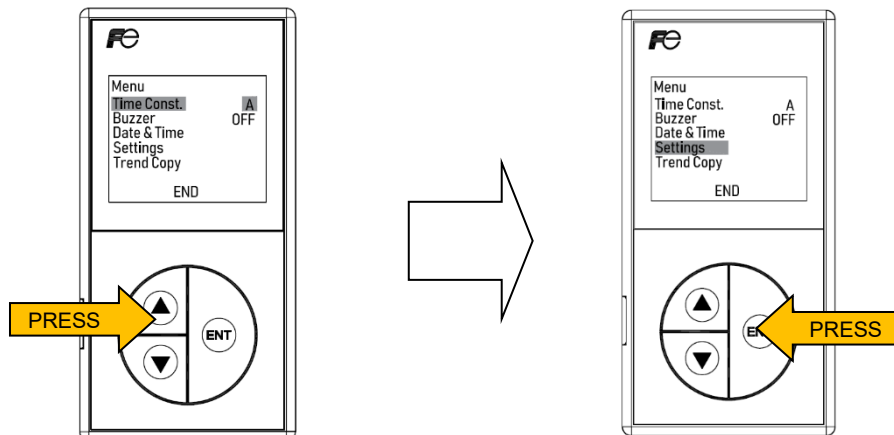

Selecting the "Settings"

- Press the "△" key or the "▽" key to select "Accum. time" and then press the "ENT" key to move the cursor to the first digit (in minutes).

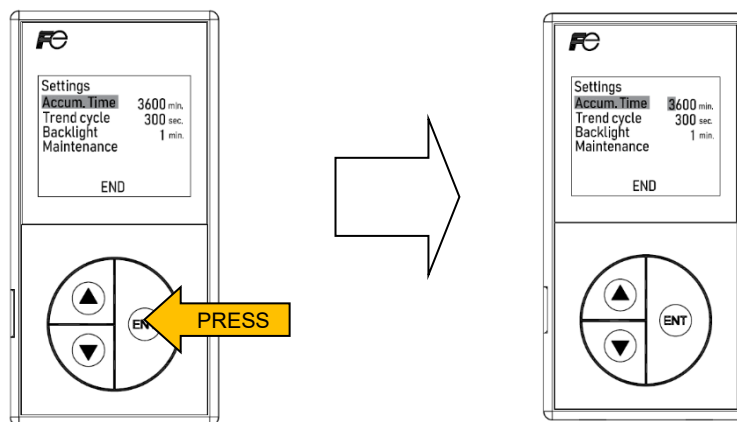

Selecting the "Accum. time"

- Press the "ENT" key to move the cursor to the preferred digit and press the "△" key or the "▽" key to select preferred value.

- After changing the time, press the "ENT" key to move the cursor to the last digit and then press the "ENT" key again. Confirm that the "SET" appears and press the "ENT" key

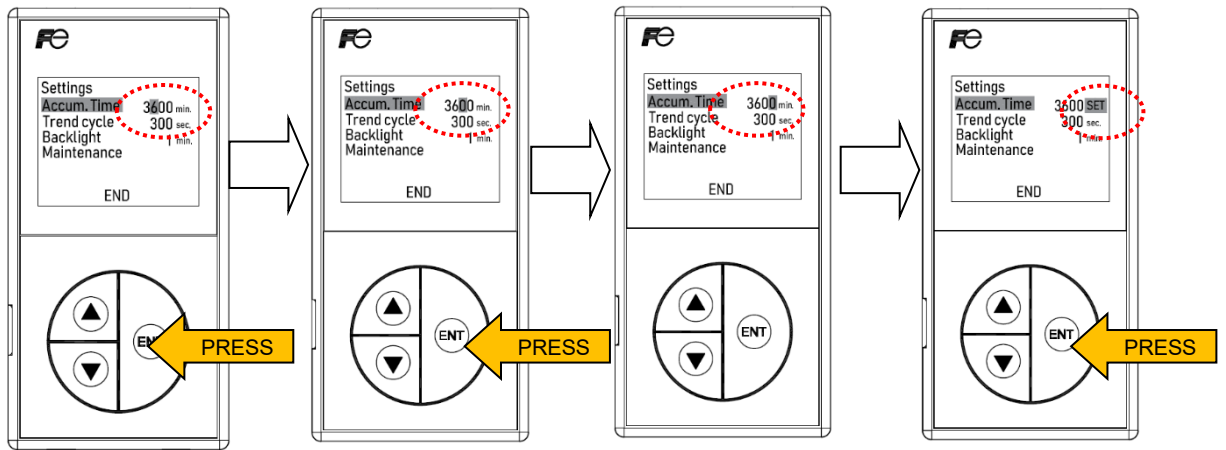

Setting the "Accum. time"

- To switch back to the "Menu", press the "△" key or the "▽" key to select "END" at the bottom of the screen and then press the "ENT" key.

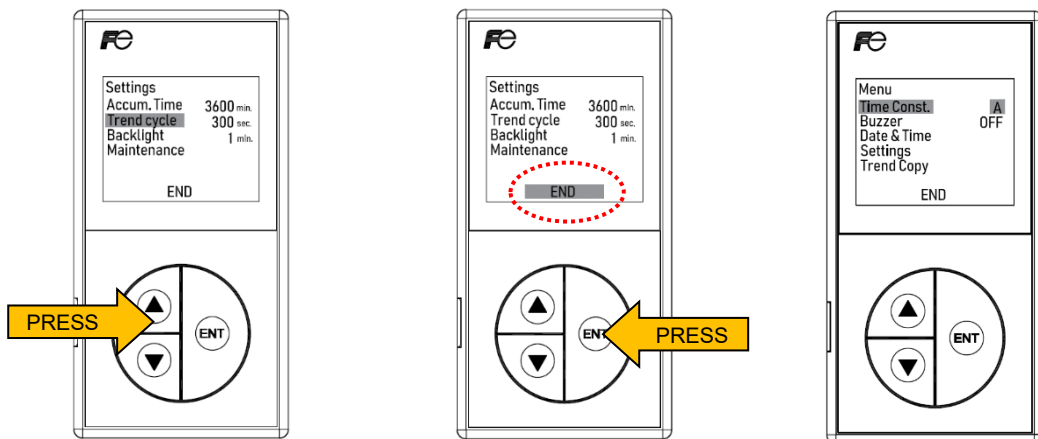

Switching back to the "Menu" screen

- To display the dose rate screen, press the "△" key or the "▽" key to select "END" and then press the "ENT" key.

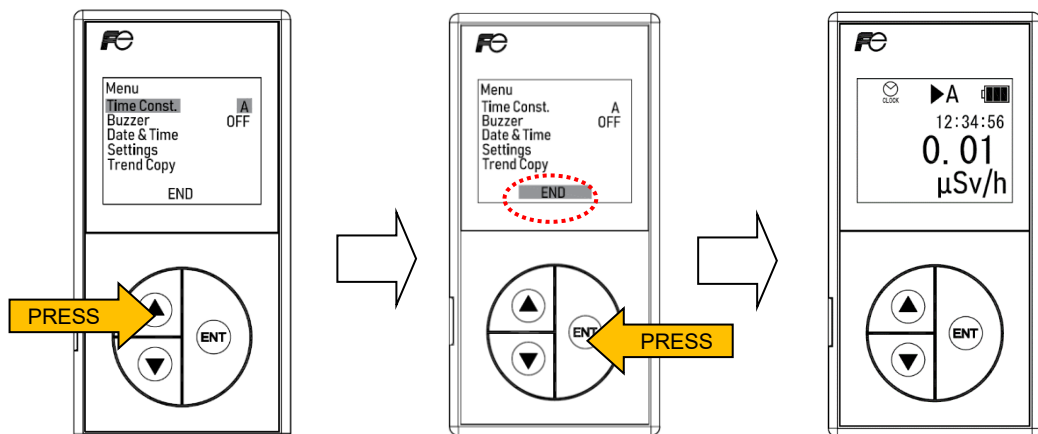

Displaying the dose rate screen

## 5.4 Backlight setting (Power-Saving mode)

To save battery life, the Display Backlight automatically turns OFF when there has been no key activity for a certain amount of time depending on the setting (1 min./5min.).

- To display the "Menu", press the "ENT" key while in the dose rate screen shown.

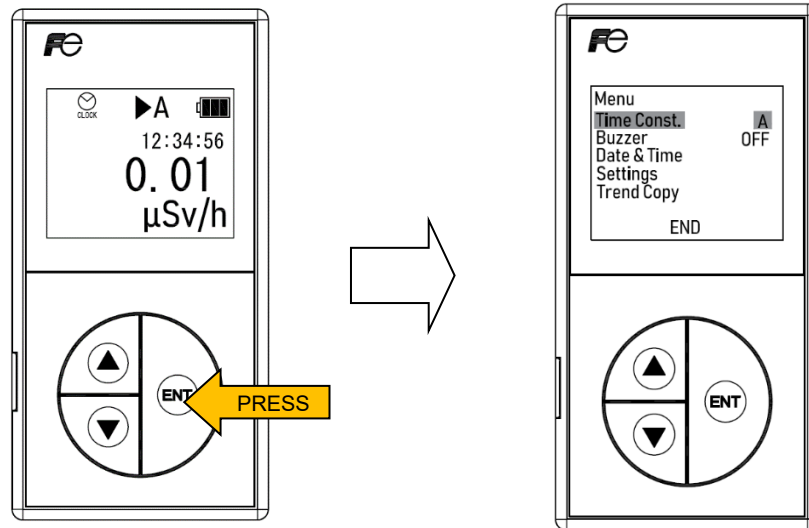

Displaying the "Menu" screen

- Press the "△" key or the "▽" key to select the "Settings" under the "Menu" and then press the "ENT" key.

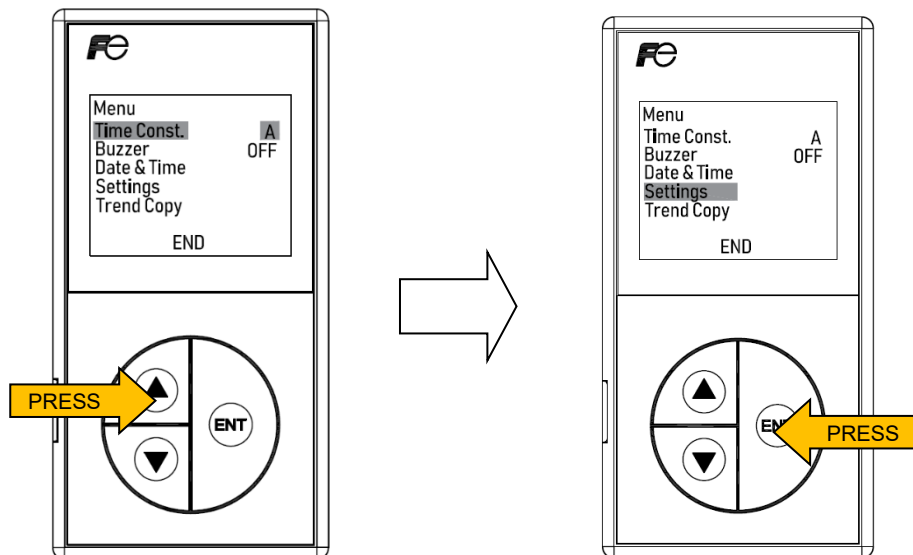

Selecting the "Settings"

- Press the "△" key or the "▽" key to select the "Backlight".

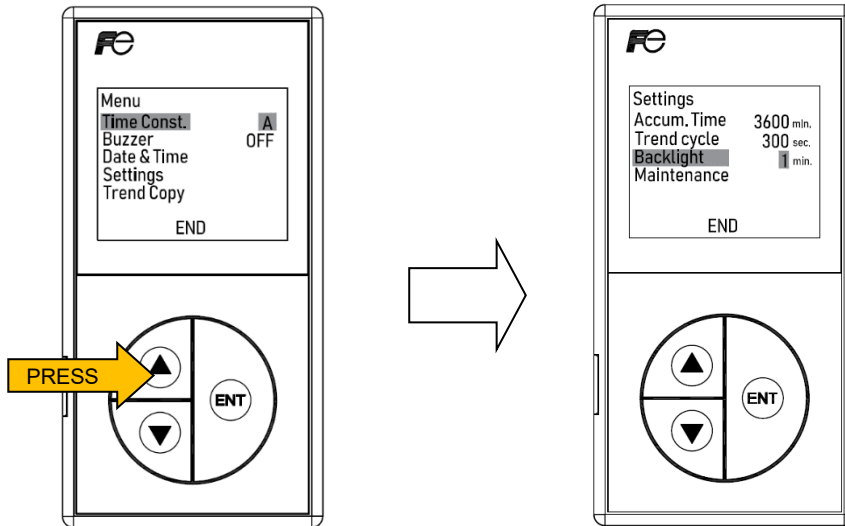

Selecting the "Backlight"

- By pressing the "ENT" key, each selection is displayed in the following order:

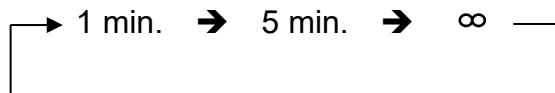

" ∞ " indicates that the display backlight will always be on.

- Press the "ENT" key to select "1 min.", "5 min." or " ∞ ". This will automatically confirm the selection.

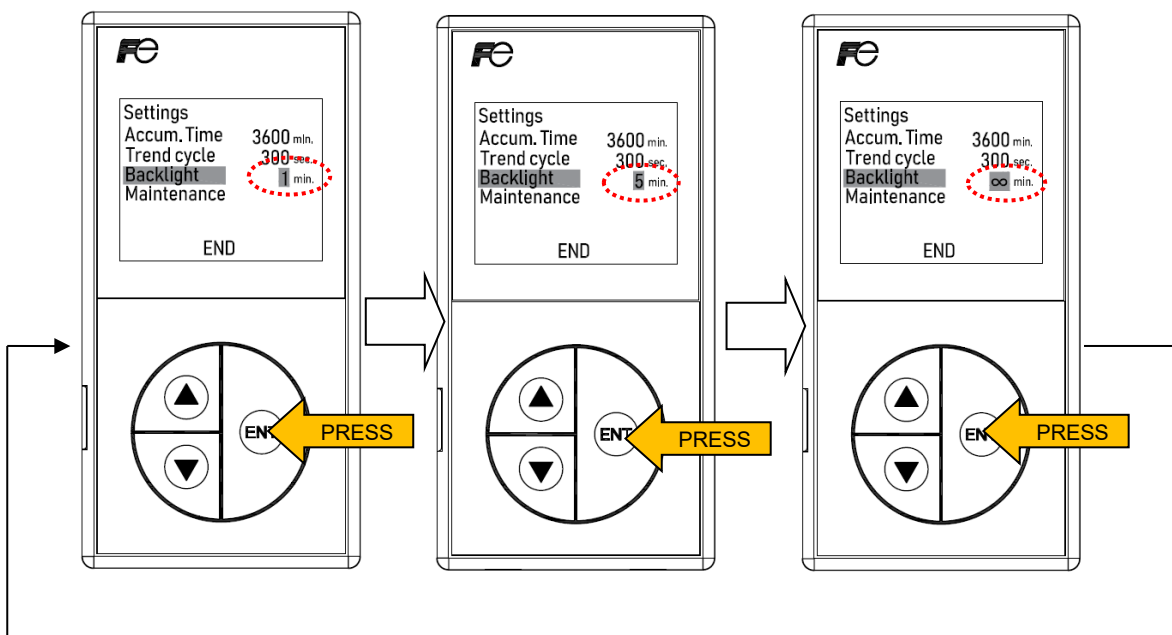

Go back to the beginning.

Selecting the "Backlight"

- To switch back to the "Menu", press the "△" key or the "▽" key to select "END" at the bottom of the screen and press the "ENT" key.

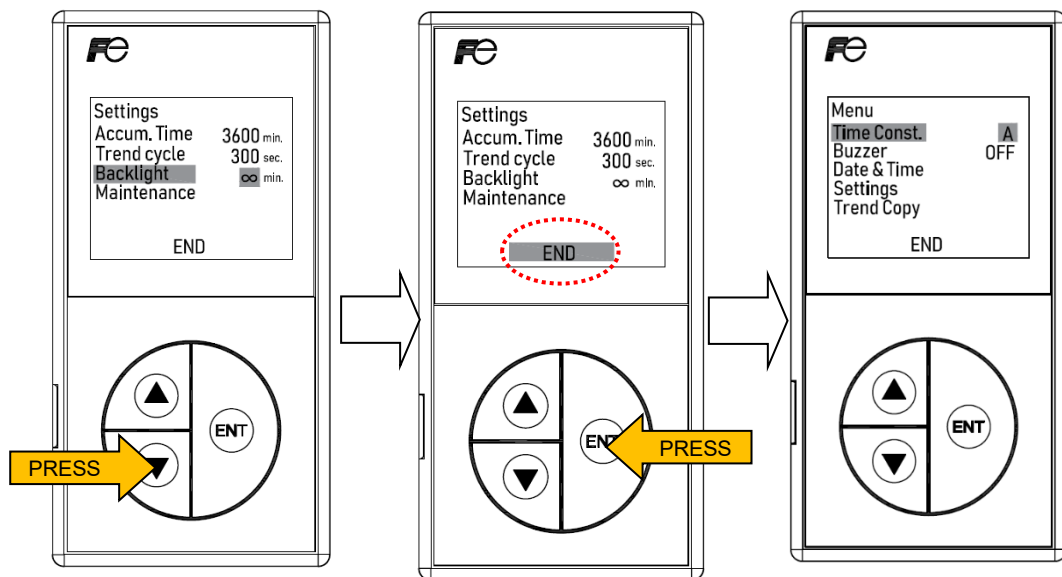

Switching back to the "Menu" screen

- To display to the dose rate screen, press the "△" key or "▽" key to select "END" and then press the "ENT" key.

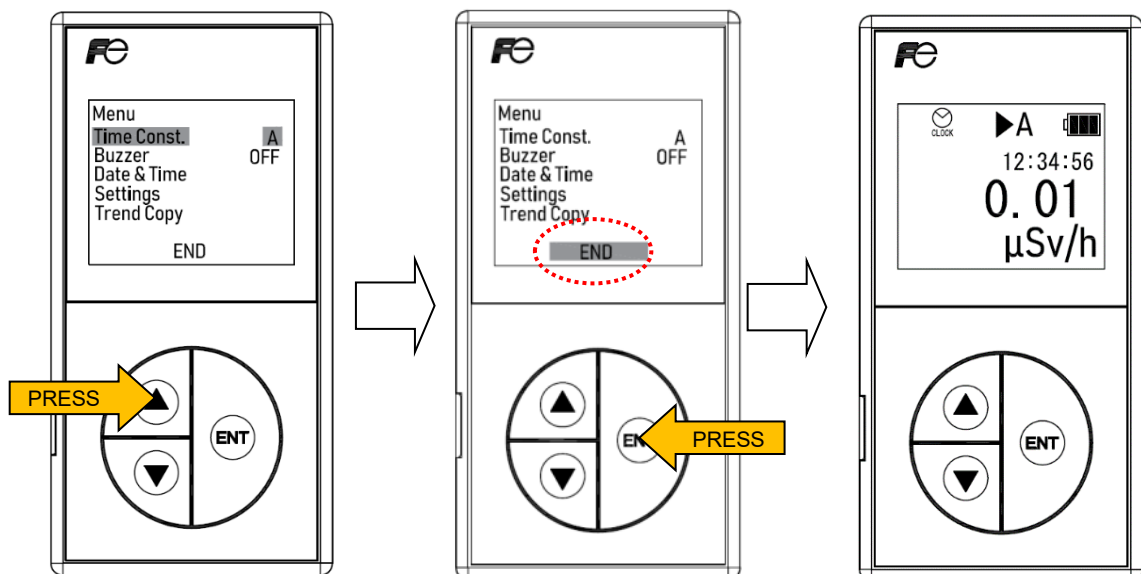

Displaying the dose rate screen

- While in the power saving mode, press the "△" key, the "▽" key or the "ENT" key to turn ON the display backlight.

## 5.5 Buzzer (monitoring sound)

The "Buzzer" (Monitoring sound) can be turned ON/OFF depending on the environmental factors.

- To display the "Menu", press the "ENT" key while in the dose rate screen shown.

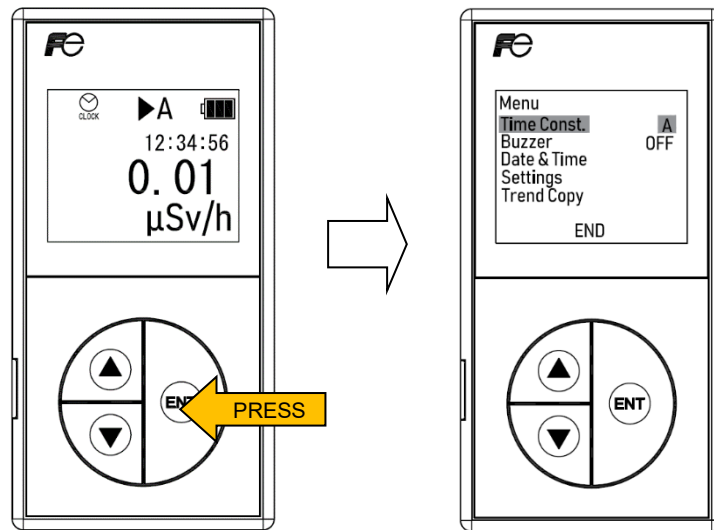

Displaying the "Menu" screen

- Press the "△" key or the "▽" key to select the "Buzzer".

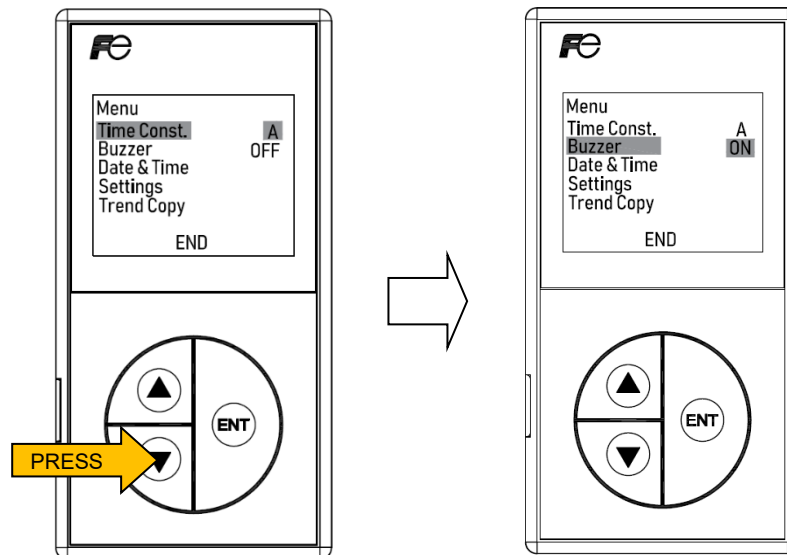

Selecting the "Buzzer"

- Press the "ENT" key to select "ON" or "OFF". This will automatically confirm the selection.

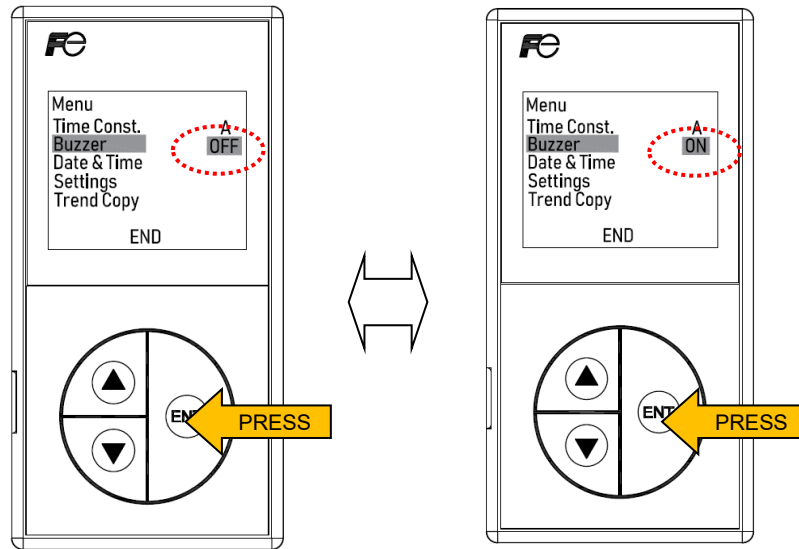

Selecting the "Buzzer"

When the buzzer is turned "ON", the "  indicator is displayed on the measurement screen and monitoring sound activates.

- To display the dose rate screen, press the "△" key or the "▽" key to select "END" and then press the "ENT" key.

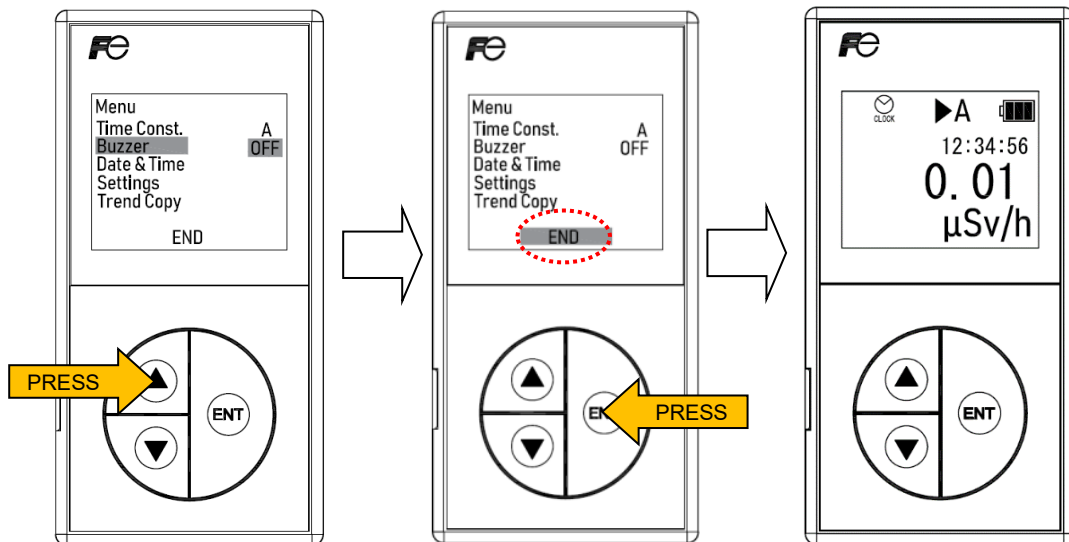

Displaying the dose rate screen

## 5.6 Trend data storage cycle

Select from the 8 time selections depending on the environmental factors. The default setting is 300 seconds.

- To display the "Menu", press the "ENT" key while in the dose rate screen shown.

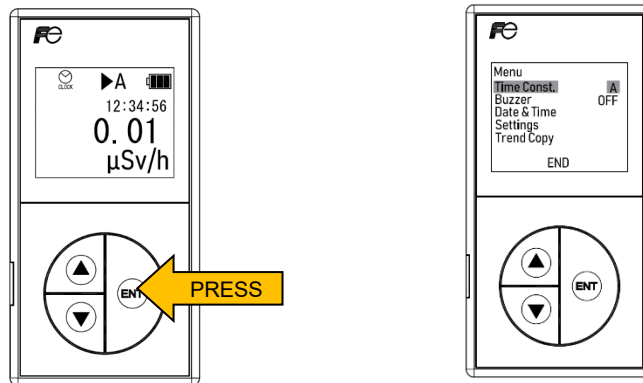

Displaying the "Menu" screen

- Press the "△" key or the "▽" key to select "Settings" under the "Menu" and then press the "ENT" key.

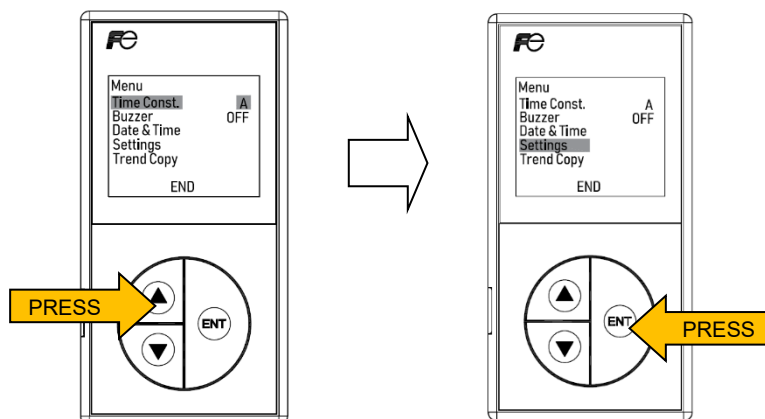

Selecting the "Settings"

- Press the "△" key or the "▽" key to select the "Trend cycle" and then press the "ENT" key.

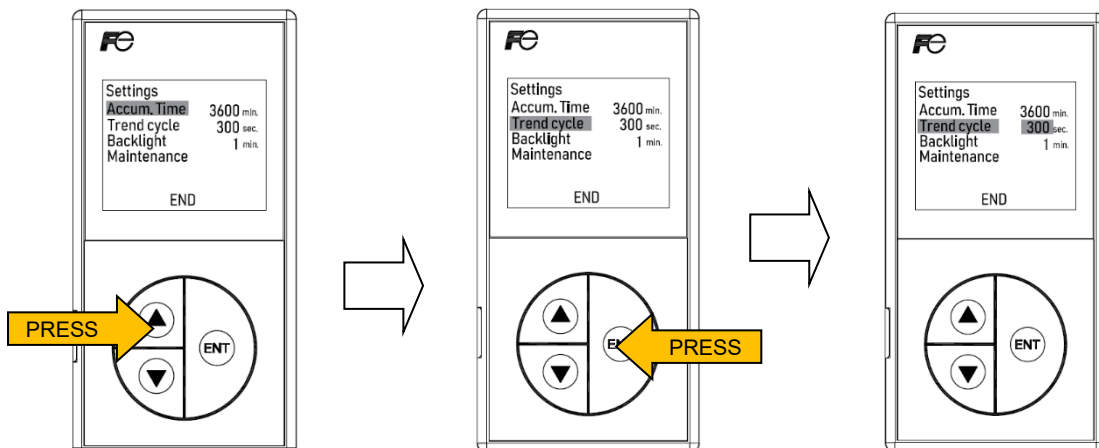

Selecting the "Trend cycle"

- By pressing the "△" key or the "▽" key, each selection is displayed in the following order:

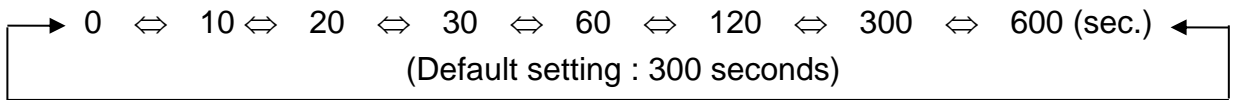

When " 0 " is selected, then the data storage is not carried out.

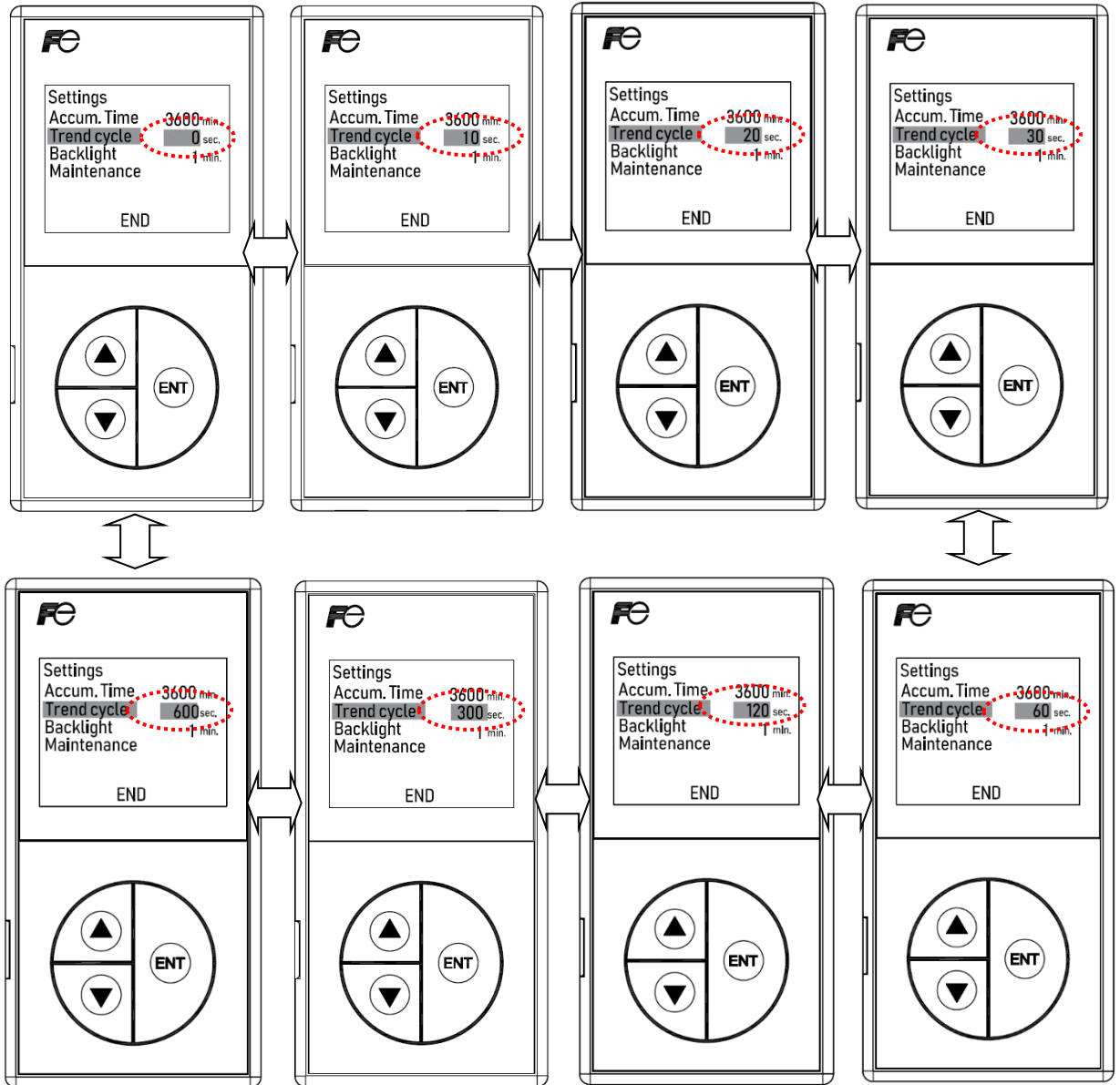

Selecting the "Trend cycle"

- Press the "△" key or the "▽" key to select "0", "10", "20", "30", "60", "120", "300" or "600" (seconds) and then press the "ENT" key. Confirm that "SET" appears and then press the "ENT" key again.

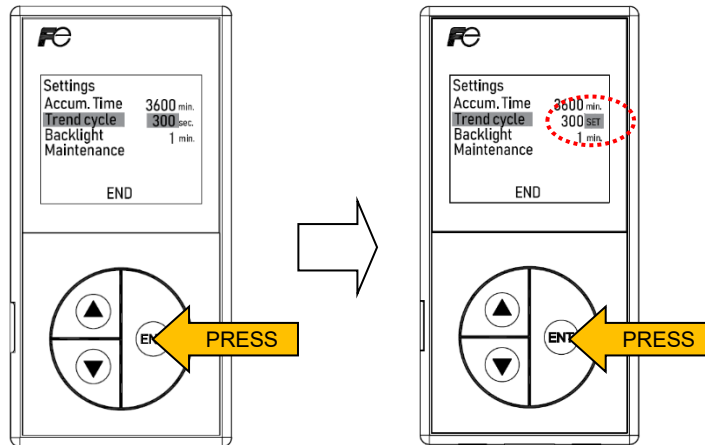

Setting the "Trend cycle"

- To switch back to the "Menu", press the "△" key or the "▽" key to select "END" at the bottom of the screen and press the "ENT" key.

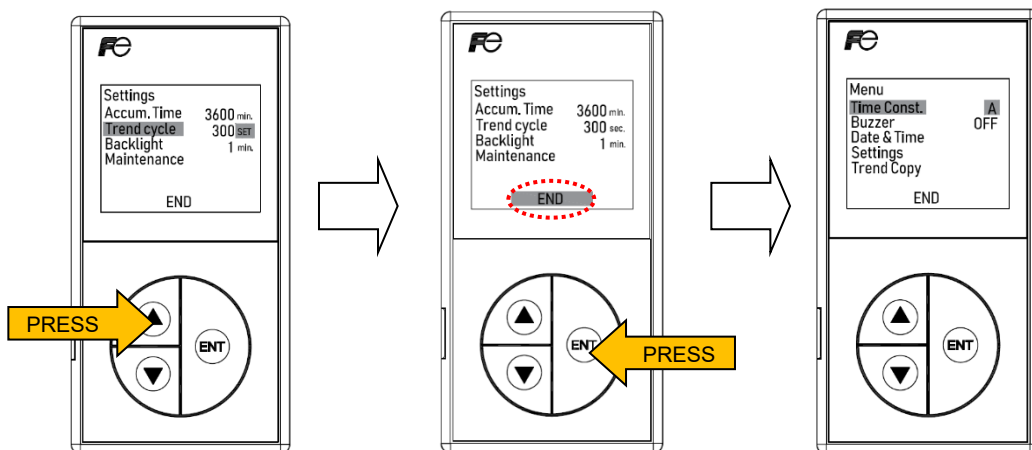

Switching back to the "Menu" screen

- To display the dose rate screen, press the "△" key or the "▽" key to select "END" and then press the "ENT" key.

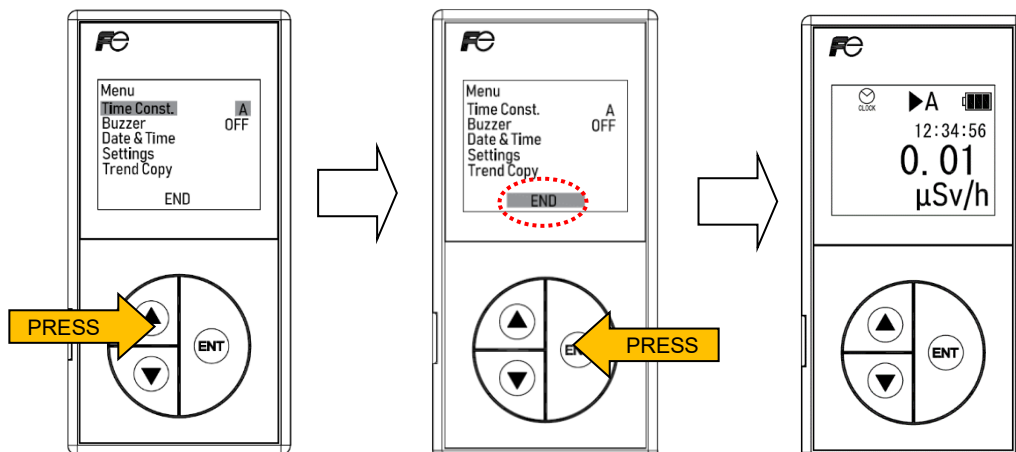

Displaying the dose rate screen

## 5.7 Date & time setting

- To display the "Menu", press the "ENT" key while in the dose rate screen shown.

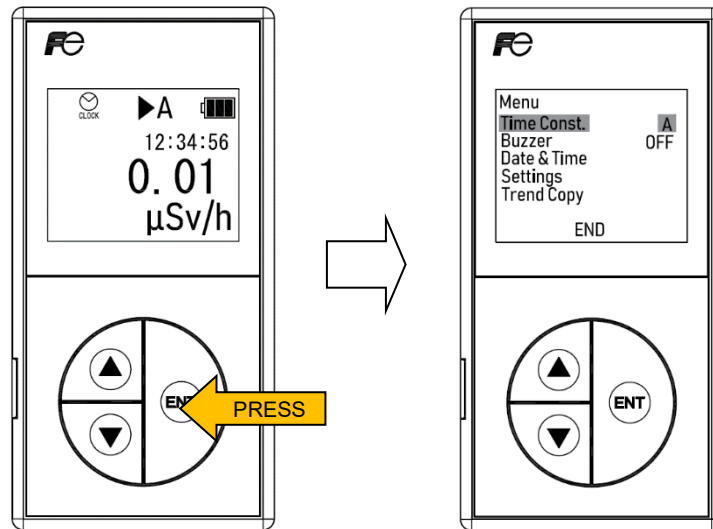

Displaying the "Menu" screen

- Press the "△" key or the "▽" key to select the "Date & Time" and then press the "ENT" key.

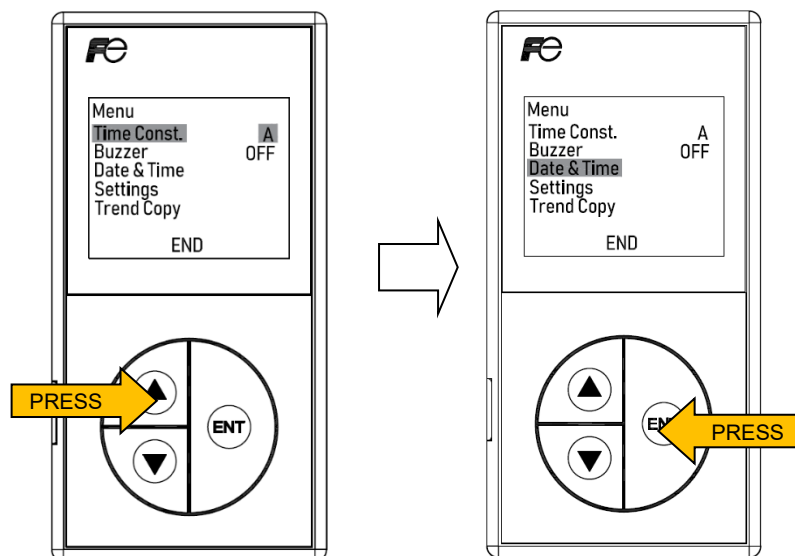

Selecting the "Date & Time"

- Press the "△" key or the "▽" key to change the last 2 digits to the preferred figure.  
For example: The Year 2009 should be entered as "09 Y."

- Move the cursor by pressing the "ENT" key. The cursor moves in the following order:

> NSN31047 : "Y"(Year), "M" (Month), "D" (Day), "h" (Hours) , and "m" (Minutes: Final Digit)

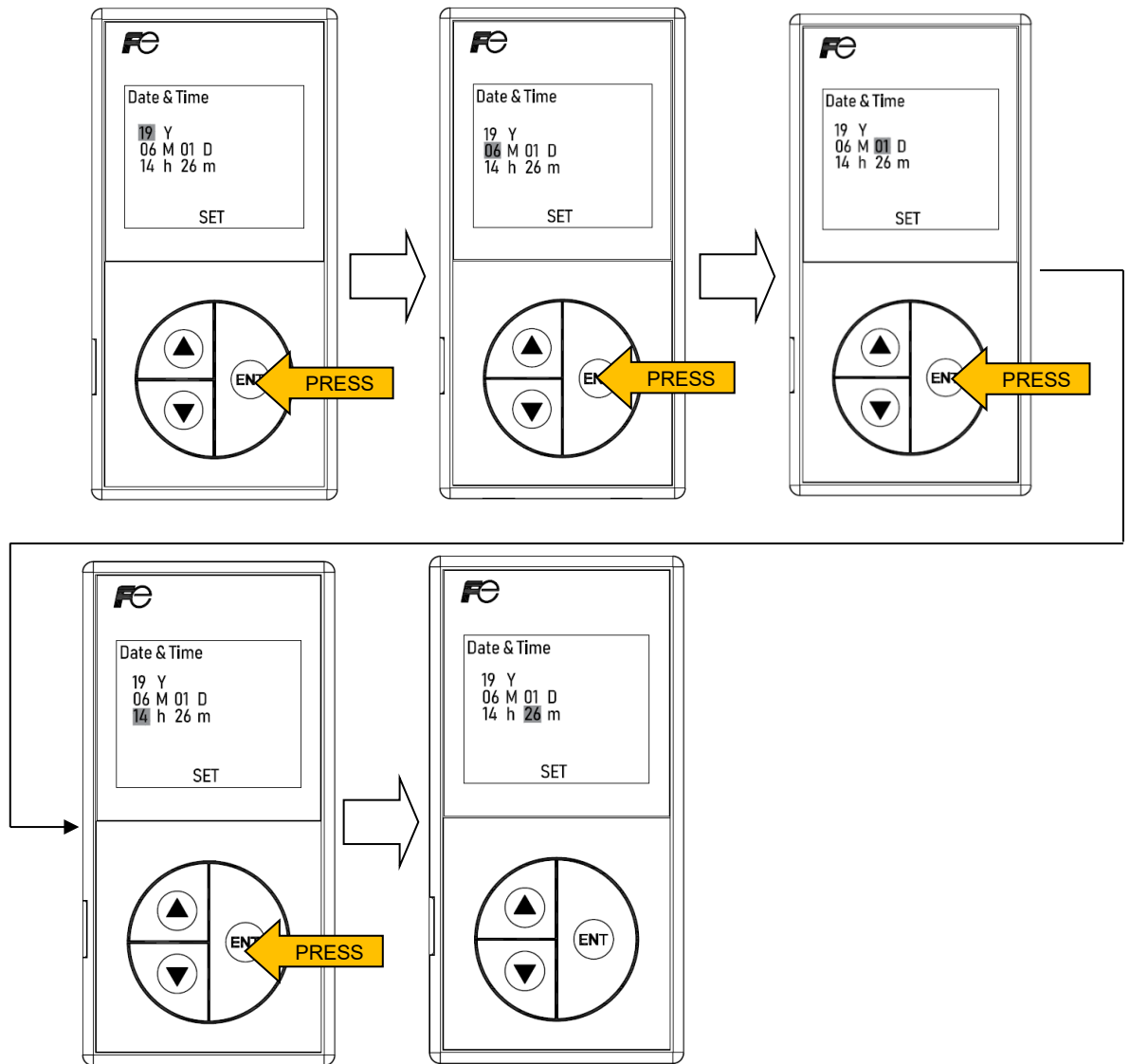

Selecting the "Date & Time"

- Repeat the above procedure to set each value.  
The time value in "seconds" is set to " 0 " automatically.

- After changing the Date and Time, press the "ENT" key to move the cursor to "m" (Minutes : Final digit) and then press the "ENT" key again. Confirm that "SET" is highlighted at the bottom of the screen. Press the "ENT" key to confirm.

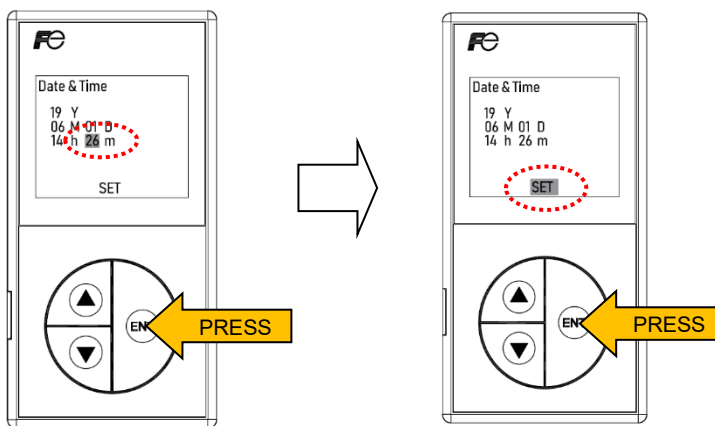

Setting the "Date & Time"

- To cancel the selections, press the "ENT" key to move the cursor to "m" (Minutes : Final digit). Press the "ENT" key again and then confirm that "SET" is highlighted at the bottom of the screen. Press the "△" key or the "▽" key to select "CXL" and then press the "ENT" key.

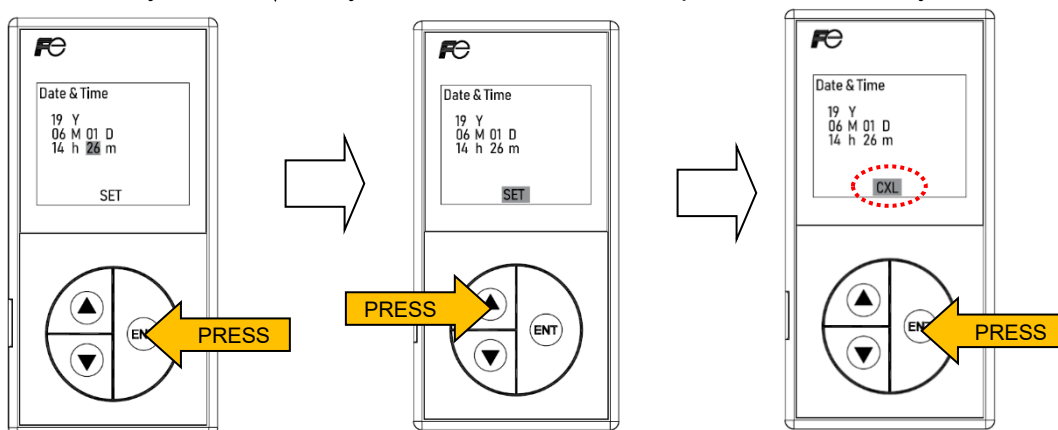

Cancelling the "Date & Time"

- To display the dose rate screen, press the "△" key or the "▽" key to select "END" and then press the "ENT" key.

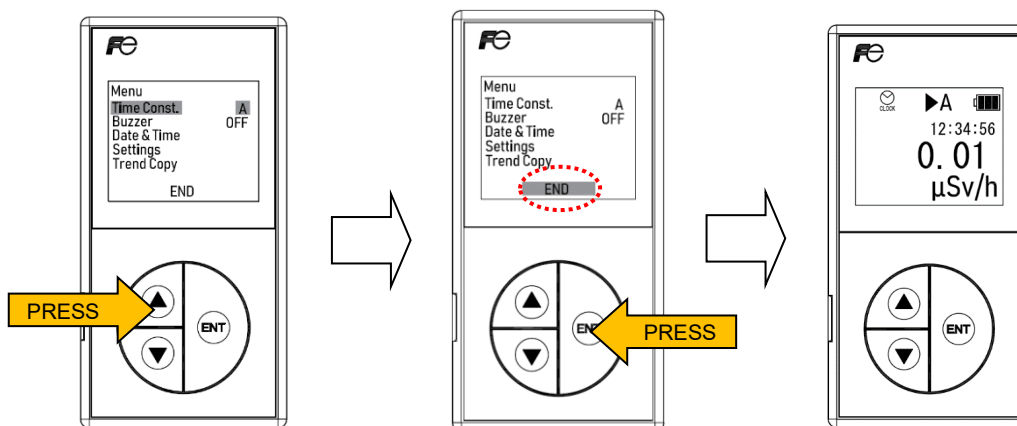

Displaying the dose rate screen

## 5.8 Copy of trend data

When turning ON the survey meter, the main body of the **NSN3** automatically collects and stores the trend data according to the trend data storage cycle (refer to the section 5.7). The default setting of the data storage cycle is 60 seconds at the time of shipment. Up to 1200 data records can be stored in the main body. When there are more than 1200 records, the data records are automatically overwritten beginning with the chronologically oldest record, so there is no need for the user to reset the trend data. It is capable of copying the Trend data into the display unit memory as backup data by the following procedures:

- To display the "Menu", press the "ENT" key while in the dose rate screen shown.

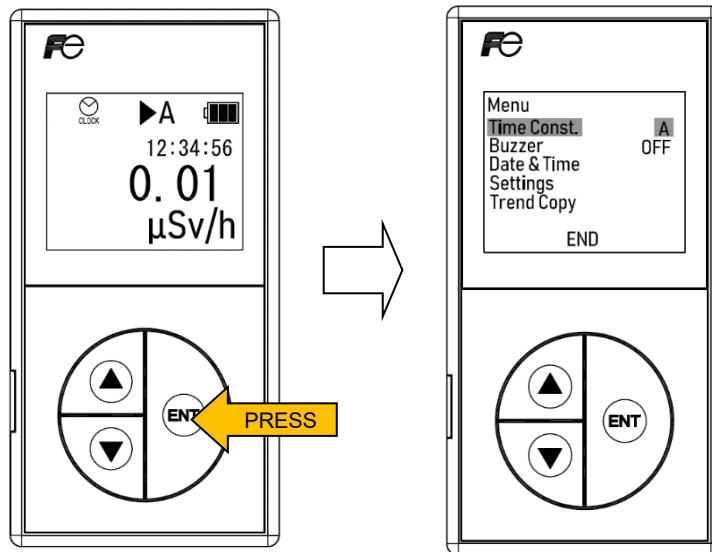

Displaying the "Menu" Screen

- Press the "△" key or the "▽" key to select the "Trend Copy" and then press the "ENT" key.

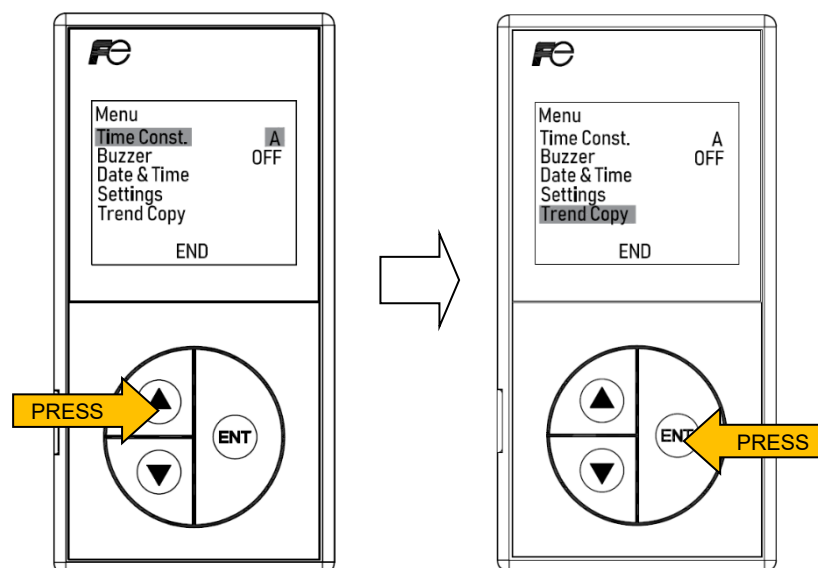

Selecting the "Trend Copy"

- Confirm that the message: "Now operating. Don't turn off" appears.  
The total number of trend data records and of copied data records are displayed.

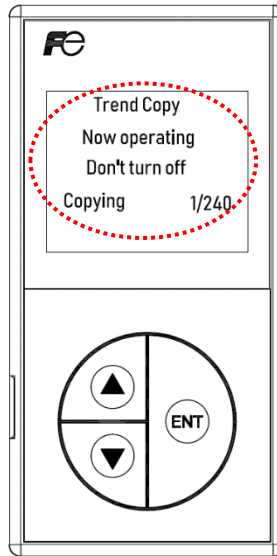

Displaying the message

- Once it reaches at 240/240, then the copying is completed.

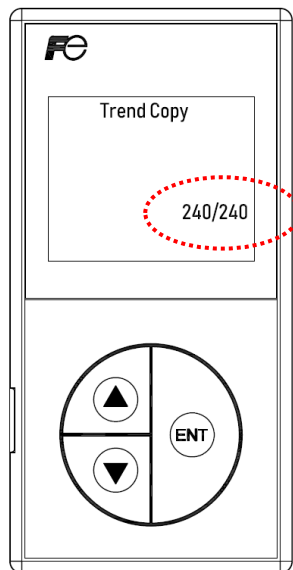

Completion of the copying

- When copying has been completed, press the "▲" key or the "▼" key. Confirm that the "CXL" is highlighted at the bottom of the screen. Press the "ENT" key and the "Menu" is displayed.

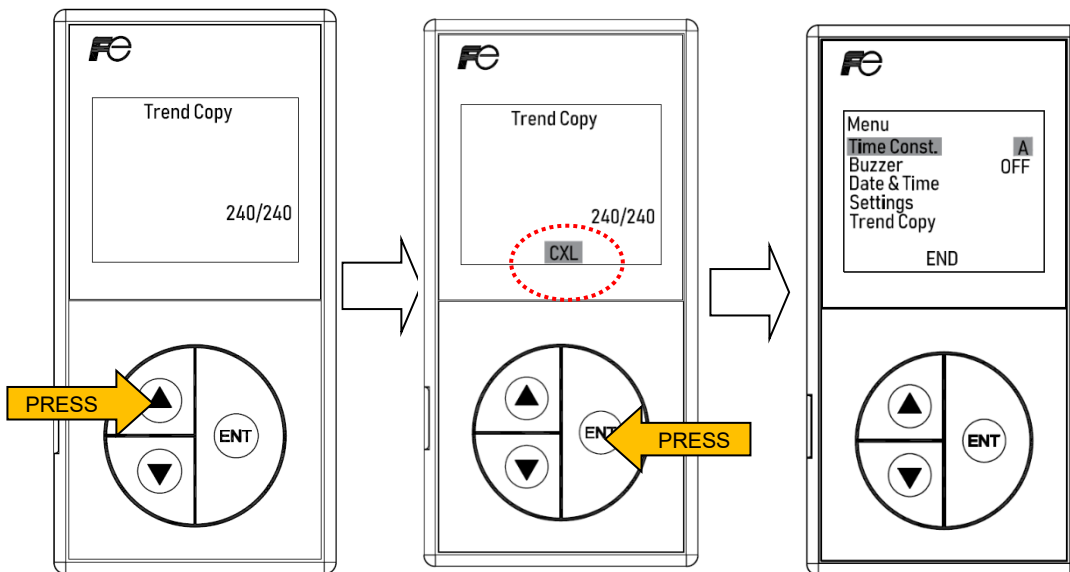

Displaying the "Menu" screen

**Note:** The optional maintenance software is required to transfer the trend data to the PC.

- To display the dose rate screen, press the "▲" key or the "▼" key to select "END" and then press the "ENT" key.

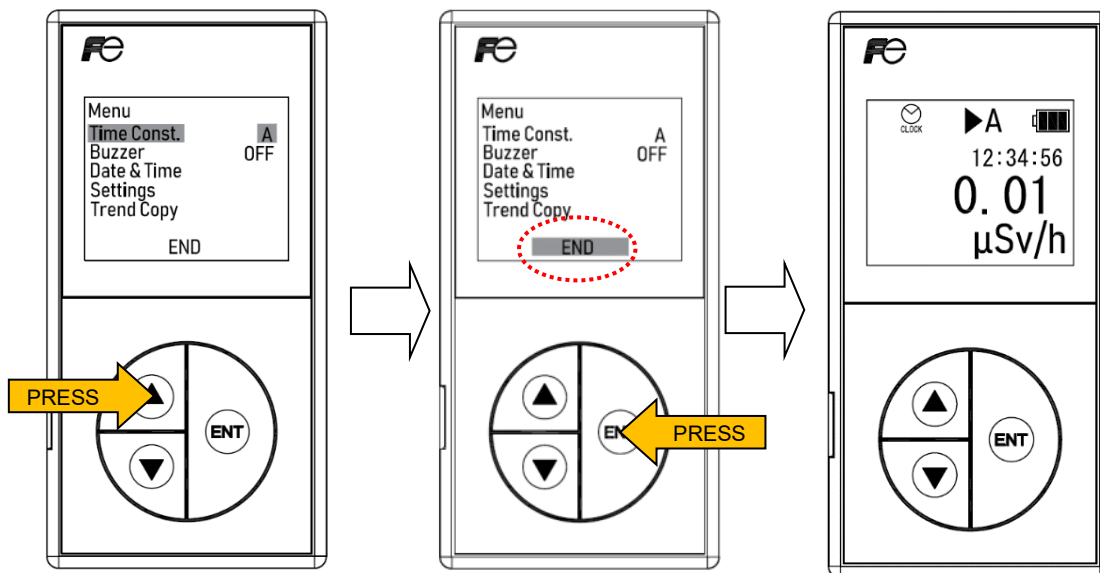

Displaying the dose rate screen

## 5.9 Maintenance

This operation displays the each ID number and each version number of the main body NSN3 and the display unit NHV1.

- To display the "Menu", press the "ENT" key while in the dose rate screen shown.

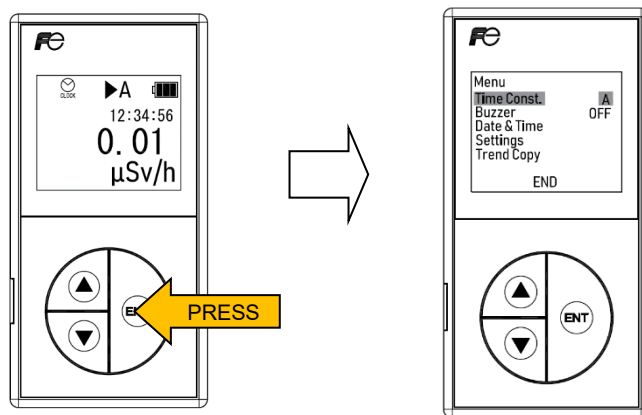

Displaying the "Menu" screen

- Press the "△" key or the "▽" key to select the "Settings" under the "Menu" and then press the "ENT" key.

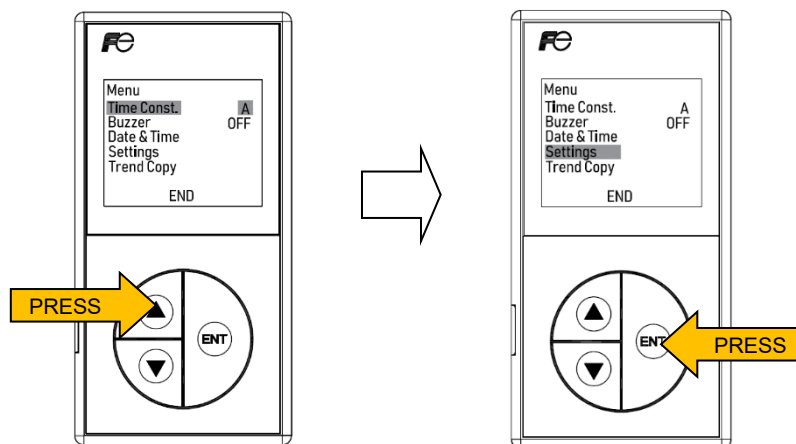

Selecting the "Settings"

- Press the "△" key or the "▽" key to select "Maintenance" and then press the "ENT" key.

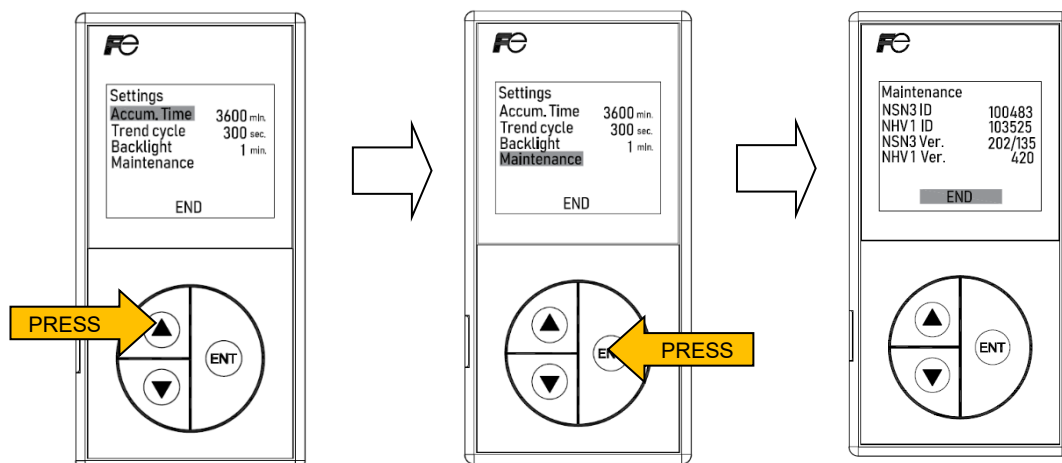

Displaying the "Maintenance" screen

- To switch back to the "Menu", press the "ENT" key and press the " $\Delta$ " key or the " $\nabla$ " key to select "END" at the bottom of the screen and press the "ENT" key again.

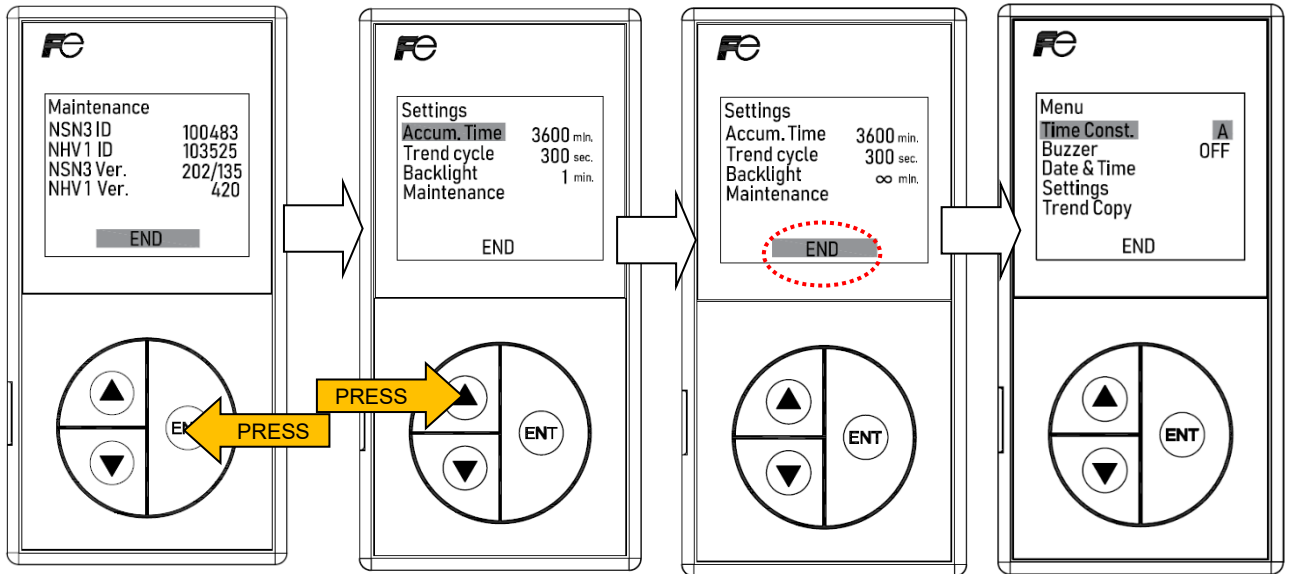

Switching back to the "Menu" screen

- To display to the dose rate screen, press the " $\Delta$ " key or the " $\nabla$ " key to select "END" and then press the "ENT" key.

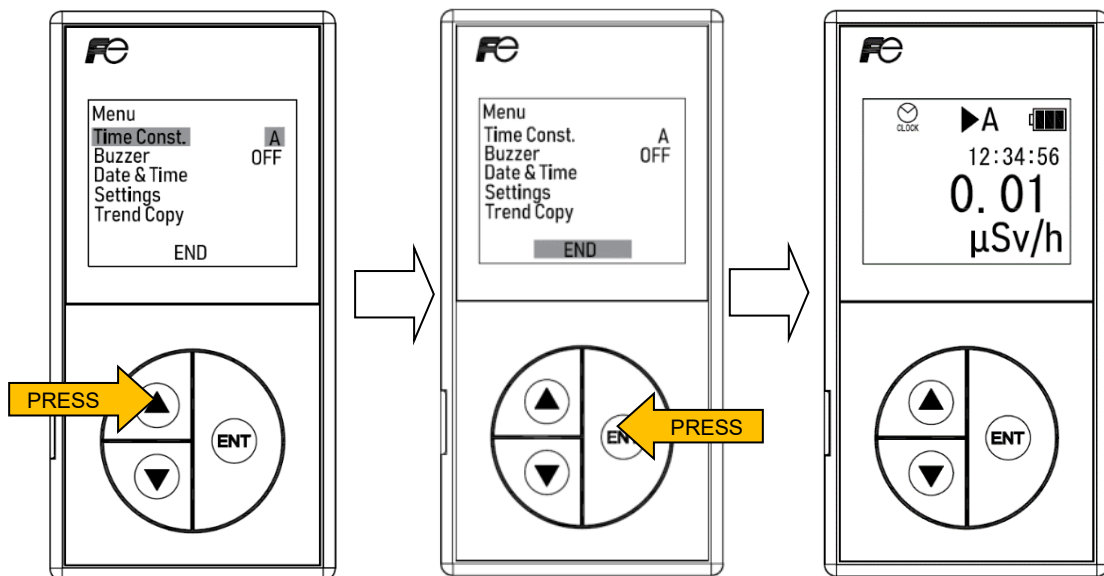

Displaying the dose rate screen

## 6. Maintenance

### 6.1 Maintenance and inspection procedures

The Maintenance procedures are described in Table 6-1. The maintenance and inspection procedures are described in Table 6-2.

Table 6-1 Maintenance procedures

No	Item	Description
1	Storage method	Turn OFF the <b>NSN3</b> and remove the all batteries. Store the <b>NSN3</b> into a plastic bag.
2	Storage environment	Temperature : -10 to +45 °C (14 to 113 F) Humidity: : 35 % to 85 % (non-condensing)  Other conditions: Store in an environment with low neutron dose rate and free of : <ul style="list-style-type: none"> <li>- Dust</li> <li>- Direct sunlight</li> <li>- Vibrations</li> <li>- Electromagnetic waves</li> <li>- Rain</li> </ul>
3	Inspection before use	For the longer storage periods, either the dust or the dirt may collect on the product. Check the following:  Clean any dust on the surface of the power connector and the display unit with a dry cloth or soft brush.  Insert six batteries, observing the polarity marks (+/-) inside the battery compartment and turn ON/OFF the power switch 2 or 3 times, and then check that displays appear on the display unit. (The system powers down approximately 1.5 seconds after switching OFF )

 <b>Attention</b>	<ul style="list-style-type: none"> <li>- When using the AA Ni-MH batteries, open the battery cover and replace all the used batteries with fresh or fully charged batteries. When using the standard AA alkaline batteries, replace all the used batteries with the new ones.</li> <li>- Always recharge the batteries if they have been stored for more than one month.</li> <li>- Recharge the AA Ni-MH rechargeable batteries by using the designated battery charger (optional).</li> <li>- Remove all the batteries when storing the <b>NSN3</b>. Failure to do this may result in battery corrosion.</li> <li>- Do not mix the battery types (For example: AA alkaline batteries with AA Ni-MH rechargeable batteries).</li> </ul>
---	--

Table 6-2 Maintenance

No	Item	Description
1	Battery replacement (Standard AA alkaline batteries)	<ul style="list-style-type: none"> <li>- When the battery power is low, replace the used batteries with the new ones.</li> <li>- Refer to the section 6.3 for details on the "Battery replacement".</li> </ul>
2	Recharging the batteries (AA Ni-MH rechargeable batteries)	<ul style="list-style-type: none"> <li>- When battery power is low, recharge the AA Ni-MH rechargeable batteries.</li> <li>- Refer to the Section 6.3 for details on "Battery replacement".</li> <li>- Depending on the operational environment, we recommend that the Ni-MH rechargeable batteries are replaced after the period of one year of operation or 400 charge/discharge cycles.</li> </ul>
3	Dust Removal	<ul style="list-style-type: none"> <li>- Clean either the dust or the dirt inside the USB terminal and the signal connector with a dry cloth or soft brush.</li> <li>- If they are dirty, thoroughly clean them with the ethanol-soaked wipes. Do not use ethanol near heat, sparks or flame. This may result in a fire.</li> <li>- Use ethanol only in well-ventilated areas.</li> </ul>
4	Check of Performance	<ul style="list-style-type: none"> <li>- Perform the irradiation test using sources such as <math>^{252}\text{Cf}</math> or <math>^{241}\text{Am-Be}</math> to measure the dose rate immediately after purchase. Carry out the irradiation test annually under the same geometrical conditions as that at the time of purchase. Compare the two measured values.</li> <li>- If the instrument needs calibration, we request that you contact our sales representative or agency.</li> </ul>

## 6.2 Replacement parts

Contact our sales representative or agency when replacing the following parts

Table 6-3 Replacement parts

No	Item	Cycle	Type	Fuji Electric number	Remarks
1	MAXELL button-type battery	10 year	CR2032	R79219N16	Battery backup of RTC
2	Packing seal	When change No.1		TQ400977P1	
3	Handle	When damaged		TQ504295C1	NSN31047-Y11YY-S NSN31047-Y1YYY-S
4	Handle	When damaged		TQ504295C2	NSN31047-YY1YY-S NSN31047-YYYYY-S

 <b>Attention</b>	<ul style="list-style-type: none"> <li>- Always turn OFF the <b>NSN3</b> before replacing batteries.</li> <li>- When replacing batteries, insert the batteries, be sure to observe the polarity marks (+/-) inside the battery compartment.</li> <li>- Follow the waste disposal instructions at your local government when disposing the used batteries.</li> <li>- Be sure to ventilate properly when using ethanol. Inhalation of ethanol vapors may cause sickness or injury. Do not use ethanol near heat, sparks or flame. This may result in a fire.</li> <li>- Handle the check source carefully. The check source should always be handled by the fully trained personnel.</li> </ul>
---	--

### 6.3 Battery replacement

For the battery removal or the replacement, follow the procedures below:

- (1) Turn OFF the power switch of the main body.
- (2) Pressing down on point A (shown in Figure 6-1), slide the battery cover upward (in the direction indicated by the arrow) and remove it.  
In case of NSN31047-Y11YY-S and NSN31047-Y1YYYY-S, loosen the screw on point A before open the battery cap.

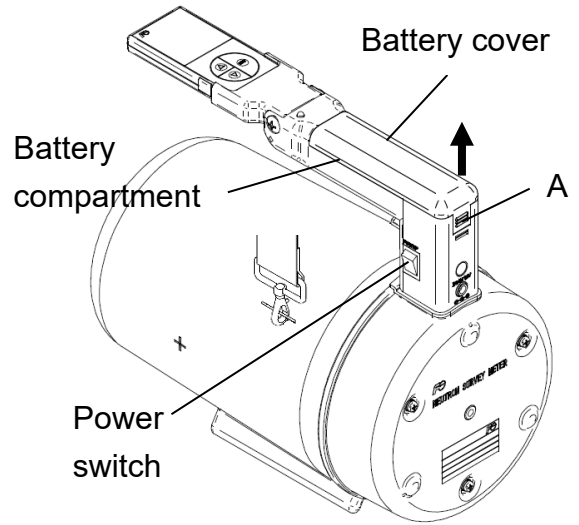

Figure 6-1 Battery removal

- (3) Remove all six batteries from the compartment.
- (4) Insert six new AA batteries (standard alkaline batteries or the Ni-MH rechargeable batteries), observing the polarity marks (+/-) inside the battery compartment as shown in Figure 6-2.  
Do not mix the battery types (i.e. the AA standard alkaline batteries with the AA Ni-MH rechargeable batteries).
- (5) Slide in the cover to the point C, press down on the point A (shown in Figure 6-2), slide down the cover to the point B (in the direction indicated by the arrow) and close the cover.

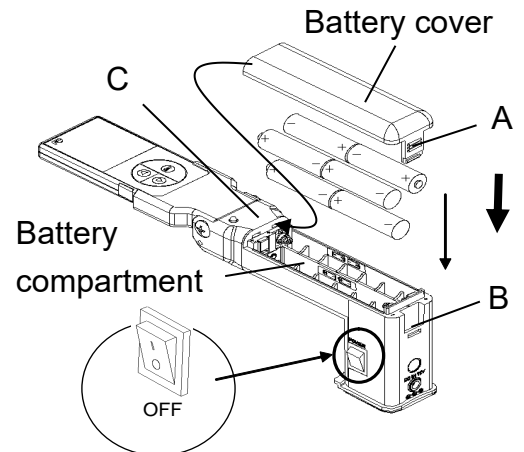

Figure 6-2 Battery insertion

In case of NSN31047-Y11YY-S and NSN31047-Y1YYYY-S, tighten the screw on point A after close the battery cap.

**Note:** Use the designated charger for the Ni-MH rechargeable batteries when recharging.



- Always turn off the **NSN3** before replacing batteries.
- Observe the polarity marks (+/-) inside the battery compartment.
- Use standard AA alkaline batteries or AA Ni-MH rechargeable batteries.
- All six batteries should be either new or fully charged.
- Follow the waste disposal instructions at your local government when disposing the batteries.
- Do not mix the battery types (the AA alkaline batteries with the AA Ni-MH rechargeable batteries).

## 6.4 Handle replacement

For the handle replacement, follow the procedures below:

- (1) Turn OFF the power switch of the main body.
- (2) Pressing down on point A (shown in Figure 6-3), slide the battery cover upward (in the direction indicated by the arrow) and remove it.  
In case of NSN31047-Y11YY-S and NSN31047-Y1YYYY-S, loosen the screw on point A before open the battery cap.

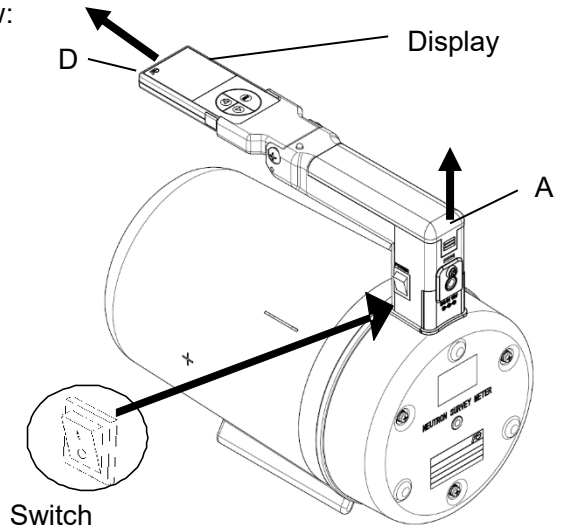
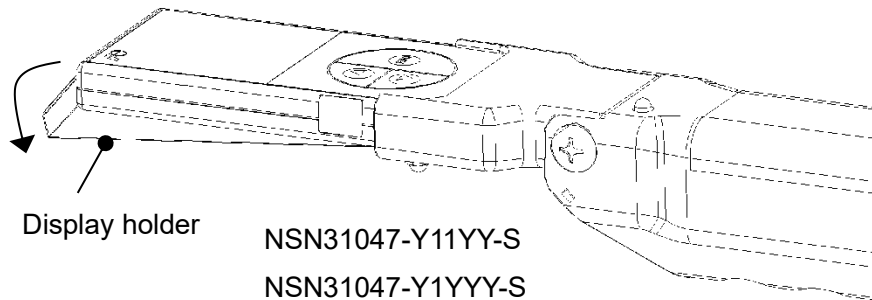
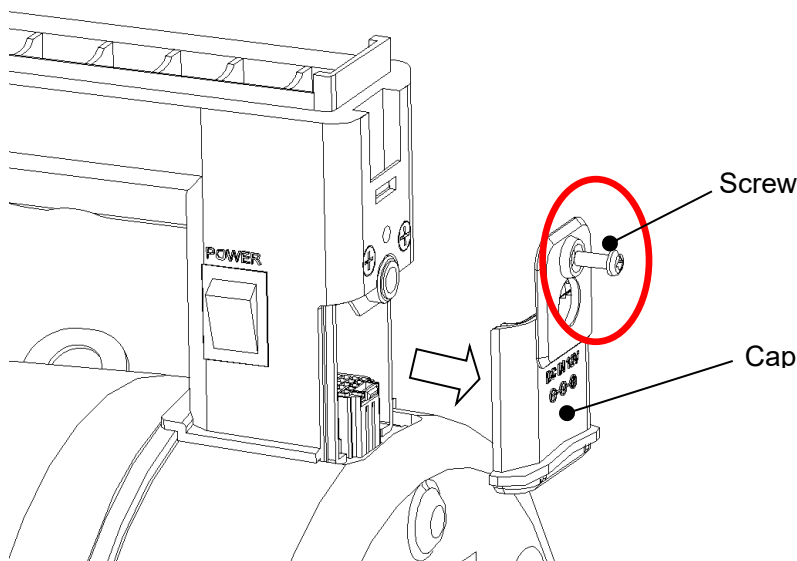

Figure 6-3 Battery removal

- (3) Remove all six batteries from the compartment.
- (4) Remove the display unit.  
In case of NSN31047-Y11YY-S and NSN31047-Y1YYYY-S, slide down the display holder at point D before remove.



- (5) Remove the screw and remove the cap.



(6) Remove the 4 screws.

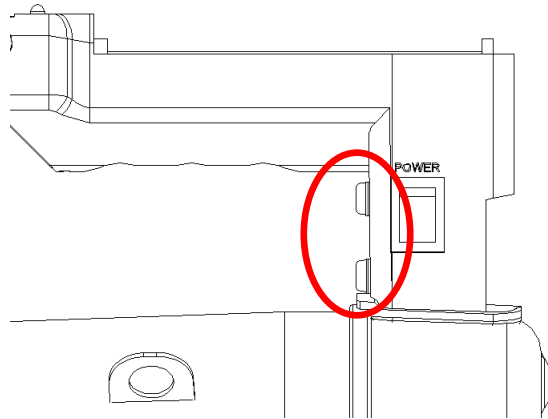
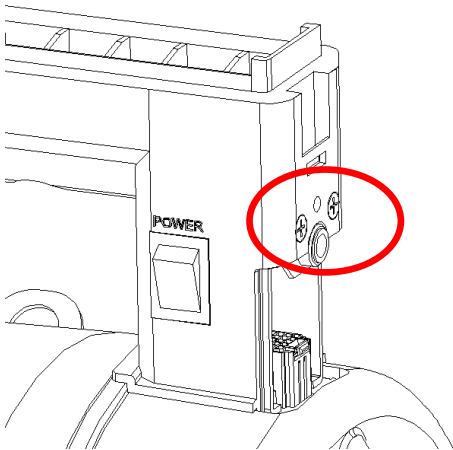

(7) Remove the handle unit upward while pressing the connector rock.

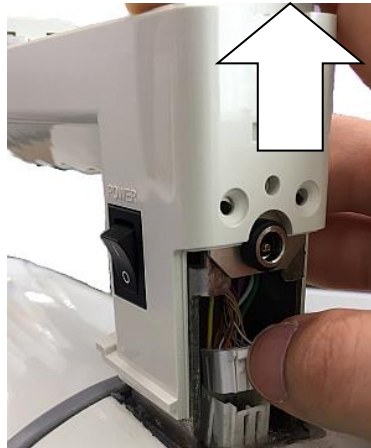
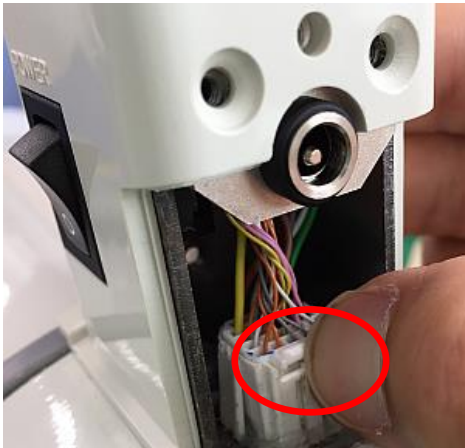

(8) Attach the new handle to NSN3 body.

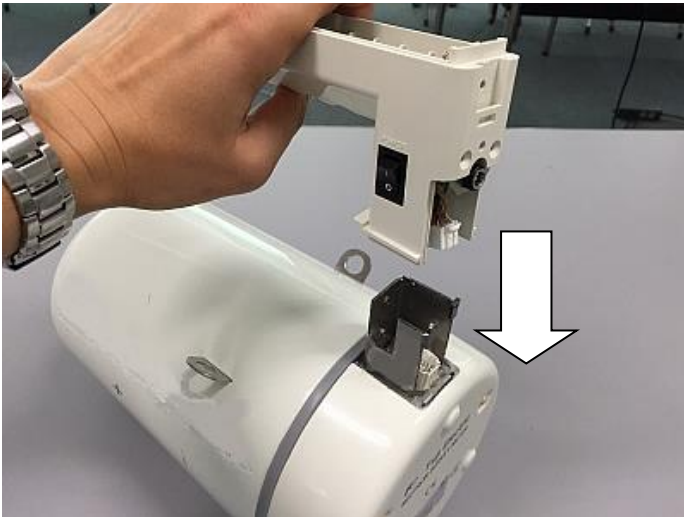

Fit the connector as below.

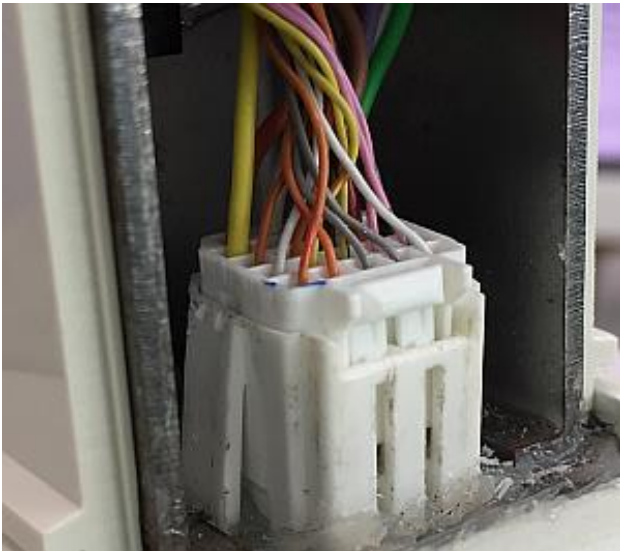

(NOT able to connect)

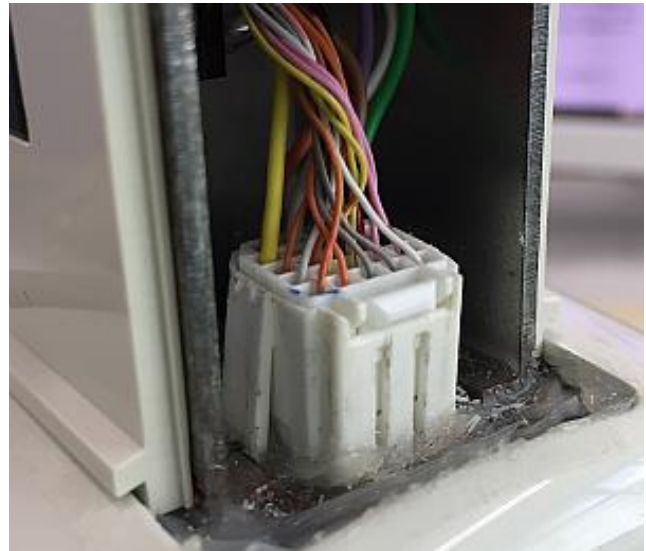

(Connected)

(9) Fasten 4 screws to fix the handle and NSN3 body.

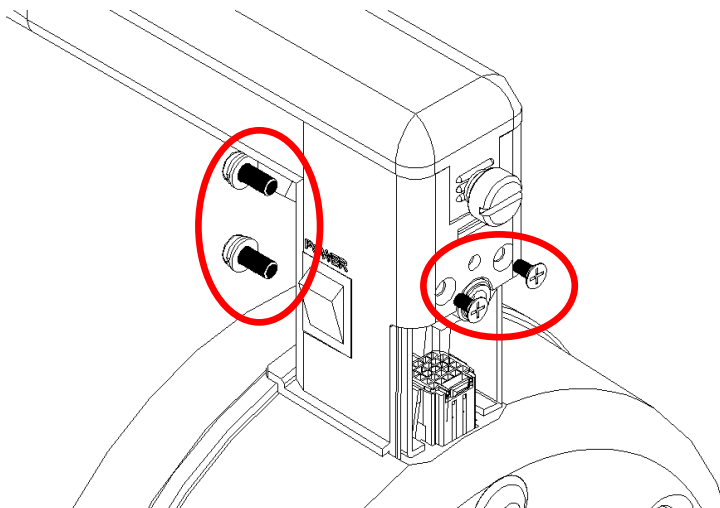

(10) Attach the cap and fasten the screw.

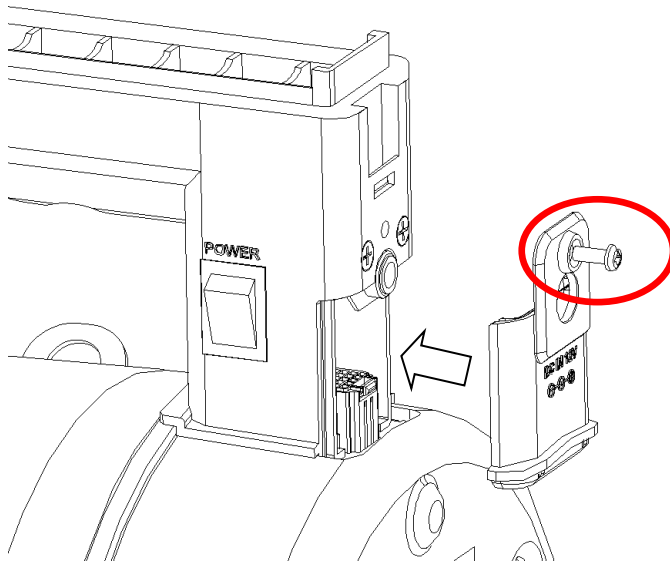

(11) Attach the display unit

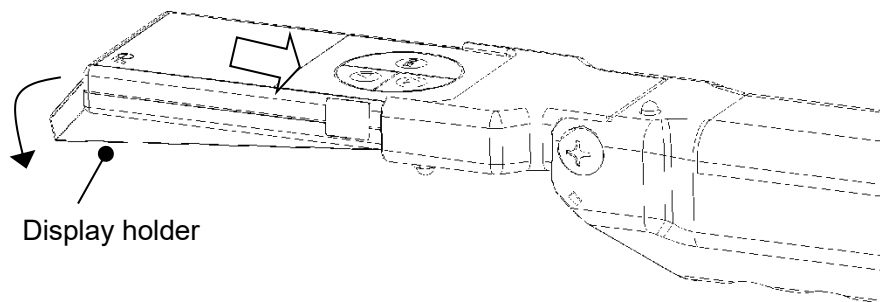

(12) Attach the battery cap.

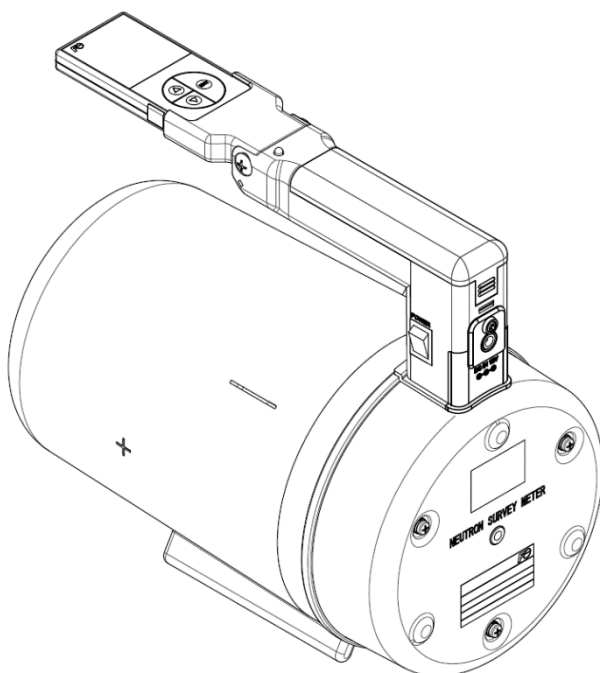

Check the looseness of handle and NSN3 body.  
When installation of a handle is loose, there is a possibility of damage the NSN3 body by falling and a possibility of your injury.

## 7. Time constant table

Table 7-1 Time constant

Measured dose rate [ $\mu\text{Sv/h}$ ]		Time constant (sec)			Measurement accuracy ( $2\sigma$ )		
		S	M	L	S	M	L
	Under 0.03	120	240	600	N/A	N/A	N/A
0.03 or over	Under 0.1	10	30	90	100%	88.2%	50.9%
0.1 or over	Under 0.2	10	30	90	83.7%	48.3%	27.9%
0.2 or over	Under 0.5	10	30	90	59.2%	34.2%	19.7%
0.5 or over	Under 1	7	20	60	44.7%	26.5%	15.3%
1 or over	Under 2	7	20	60	31.6%	18.7%	10.8%
2 or over	Under 3	3	10	30	34.2%	18.7%	10.8%
3 or over	Under 4	3	10	30	27.9%	15.3%	8.8%
4 or over	Under 5	3	10	30	24.2%	13.2%	7.6%
5 or over	Under 6	3	10	30	21.6%	11.8%	6.8%
6 or over	Under 7	3	10	30	19.7%	10.8%	6.2%
7 or over	Under 8	3	10	30	18.3%	10.0%	5.8%
8 or over	Under 9	3	10	30	17.1%	9.4%	5.4%
9 or over	Under 10	3	10	30	16.1%	8.8%	5.1%
10 or over	Under 20	3	10	30	15.3%	8.4%	4.8%
20 or over	Under 30	3	10	30	10.8%	5.9%	3.4%
30 or over	Under 40	3	10	30	8.8%	4.8%	2.8%
40 or over	Under 50	3	10	30	7.6%	4.2%	2.4%
50 or over	Under 60	2	5	15	8.4%	5.3%	3.1%
60 or over	Under 70	2	5	15	7.6%	4.8%	2.8%
70 or over	Under 80	2	5	15	7.1%	4.5%	2.6%
80 or over	Under 90	2	5	15	6.6%	4.2%	2.4%
90 or over	Under 100	2	5	15	6.2%	3.9%	2.3%
100 or over	Under 200	2	5	15	5.9%	3.7%	2.2%
200 or over	Under 300	2	5	15	4.2%	2.6%	1.5%
300 or over	Under 400	2	5	15	3.4%	2.2%	1.2%
400 or over	Under 500	2	5	15	3.0%	1.9%	1.1%
500 or over	Under 600	1.5	1.5	4.5	3.1%	3.1%	1.8%
600 or over	Under 700	1.5	1.5	4.5	2.8%	2.8%	1.6%
700 or over	Under 800	1.5	1.5	4.5	2.6%	2.6%	1.5%
800 or over	Under 900	1.5	1.5	4.5	2.4%	2.4%	1.4%
900 or over	Under 1000	1.5	1.5	4.5	2.3%	2.3%	1.3%
1000 or over	Under 2000	1.5	1.5	4.5	2.2%	2.2%	1.2%
2000 or over		1.5	1.5	4.5	2.2%	2.2%	1.2%

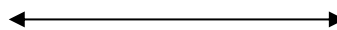

Manual setting described in section 5.1

Select from S (Short), M (Medium), L (Long) or A (Auto). In A (Auto) mode setting, the time constant values are between M and L mode setting. In case of large change of dose rate, it works as S setting mode in a short time. Refer to the section 5.1 for details on the time constant setting.

## 8. Troubleshooting

If the problem continues, please contact our sales representative or agency.

When returning the product, place it in a suitable box with appropriate packing material and label the box "Precision equipment, handle with care". Please enclose the detailed status and defect report in the box.

**Note :** This troubleshooting guide is only applicable to malfunctions that have occurred during the use of this product.

SYMPTOM	POSSIBLE CAUSE	SUGGESTED SOLUTION
No indications on the display	(1) Battery exhaustion. (2) Defective connection of the battery or the AC adapter with the electrode of the main body.  (3) Ni-MH rechargeable batteries are not charged to the full level. (4) Power switch malfunction or IC malfunction.	(1) and (2) Check that the batteries are properly inserted, observing the polarity marks (+/-) inside the battery compartment and there is no foreign material in the battery compartment.  (3) Recharge the AA Ni-MH rechargeable batteries for more than 15 hours with the designated charger.  (4) Contact our sales representative or agency.
Garbled characters on the display	(1) Defective connection between the battery and the electrode.  (2) Power switch malfunction or IC malfunction.	(1) Check that the batteries has been inserted, check polarity and there is no foreign material in the battery compartment.  (2) Contact our sales representative or agency.
No recovery from the power-saving mode even when the "△" key or the "▽" key is pressed. (Display does not light up again)	(1) Component failure of the "△" and the "▽" keys or the IC malfunction.	(1) Contact our sales representative or agency.
Dose error > Displayed dose is high abnormally > Displayed dose is low abnormally	(1) Display malfunction (garbled, etc) (2) IC malfunction (3) Counter failure (4) Calibration constant trouble	(1) (2) (3) Contact our branch or agency.  (4) Confirm a constant calibration. Please ask our branch or agency how to check the calibration constant.

SYMPTOM	POSSIBLE CAUSE	SUGGESTED SOLUTION
Dose errors: - Dose rate/ Accumulated dose readings are high. - Dose Rate/ Accumulated dose reading are low.	(1) Display malfunction (garbled characters, etc.) (2) IC malfunction. (3) Faulty counting tube. (4) Change in calibration factor. (5) Connection fault. (when the handle replacement)	(1) (2) & (3) Contact our sales representative or agency. (4) The product needs calibration. Contact our sales representative or agency for calibration methods. (5) Fix the connector between the handle unit and NSN3 body.
Inaudible monitoring beep or sound level is too low.	(When the indications such as dose rate are normal, ) (1) Defective connection of buzzer lead wire. (2) Buzzer or IC malfunction.	(1) & (2) Contact our sales representative or agency.
Battery drains quickly. (The battery life is less than 12 Hours)	(1) Drain/exhaustion of rechargeable batteries.  (2) Alkaline batteries are not used for primary batteries.	(1) Rechargeable batteries are consumables. Replace the used AA Ni-MH rechargeable batteries with new ones after the period of one year of operation or after 400 charge/discharge cycles. Use the standard AA Ni-MH rechargeable batteries as rechargeable battery. (2) Replace the used batteries with the new AA alkaline batteries. Refer to the section 6.3 for details on the "Battery replacement".
Battery drains quickly. (The battery life is less than 12 Hours)	(3) Increase in abnormal current.  (4) IC malfunction.	(3) Check that the batteries are properly inserted, observing the polarity marks (+/-) inside the battery compartment and there is no foreign material in the battery compartment. (4) Contact our sales representative or agency.
Power is not being supplied using the AC adapter.	(1) Defective connection between the AC adapter and the electrode of the main body.  (2) Diode malfunction of external power supply circuit.	(1) Clean the contact points of the AC adapter and electrode of the main body with a soft cloth and make sure that there is no foreign material in the plug-in. (2) Contact our sales representative or agency.
Communication failure occurs using the USB cable.	(1) The <b>NSN3</b> and the PC is too far apart. (2) Foreign material has adhered to the USB connector. (3) IC malfunction.	(1) The distance between the PC and the <b>NSN3</b> should be within one meter. (2) Clean the USB connector with a dry cloth or soft brush. (3) Contact our sales representative or agency.

## 9. Appendix A Characteristic for neutrons and gamma-rays

### 9.1 Relative error of indication

#### 9.1.1 Dose equivalent rate

Note) using electrical pulse

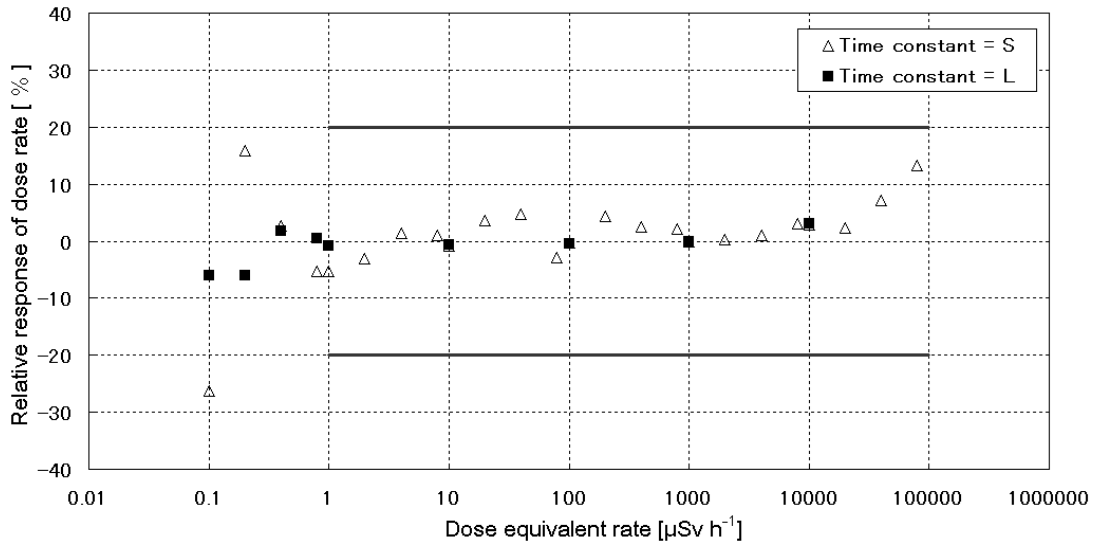

Figure 9-1-1 Relative intrinsic error of dose equivalent rate

#### 9.1.2 Accumulate dose equivalent

Note) using electrical pulse

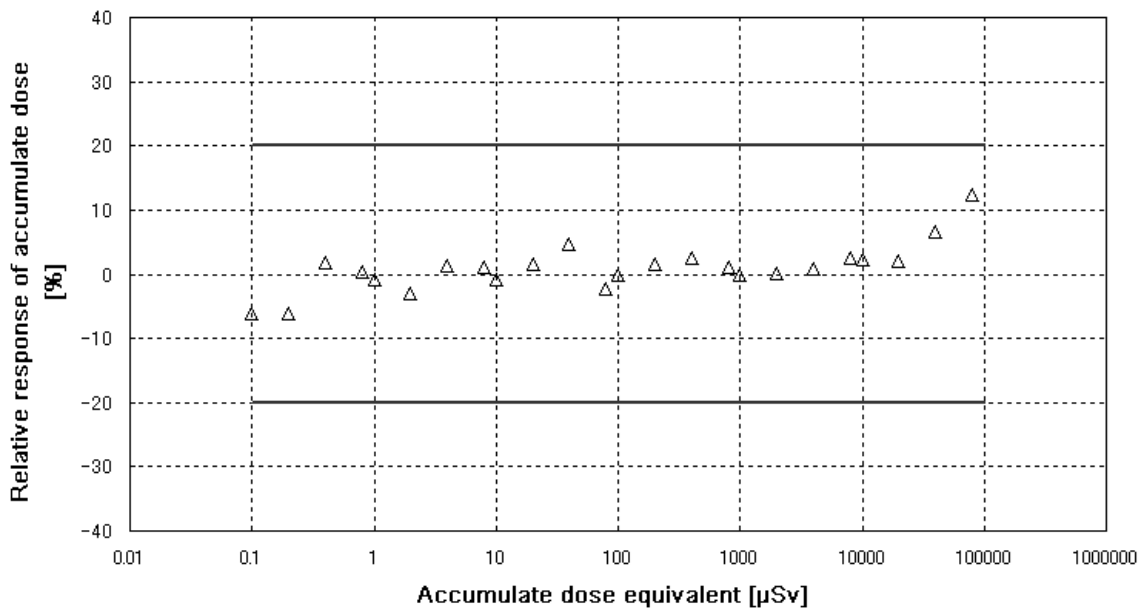

Figure 9-1-2 Relative intrinsic error of accumulate dose equivalent

## 9.2 Energy characteristics

### 9.2.1 Energy characteristics for continuous energy neutrons

Evaluated by: Japan Atomic Energy Agency (JAEA).

Neutron sources:  $^{252}\text{Cf}$  (2.13 MeV),  $^{241}\text{Am-Be}$  (4.16 MeV), thermal neutrons generated from graphite pile loading an  $^{252}\text{Cf}$  source (0.025 eV),  $\text{D}_2\text{O}$ - moderated neutrons of  $^{252}\text{Cf}$  source (550 keV), and graphite-moderated neutrons of  $^{241}\text{Am-Be}$  source (840keV).

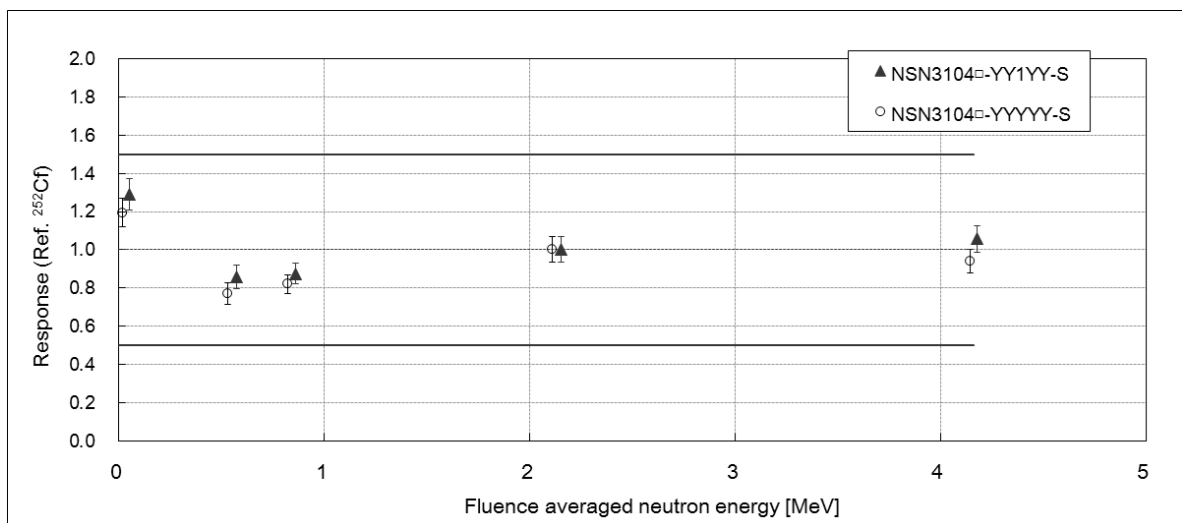

Figure 9-2-1 Energy characteristics for continuous energy neutrons

## 9.2.2 Energy characteristics for monoenergetic neutrons

Evaluated by:

- Japan Atomic Energy Agency (JAEA) : 8keV,144keV, 250keV, 565keV,14.8MeV
- National Institute of Advanced Industrial Science and Technology (AIST), (Japan),  
: 24keV, 1.1MeV, 14.8MeV
- Fast Neutron Lab. (FNL) of Tohoku University in Japan : 5MeV

Simulation calculation:

- Particle and Heavy Ion Transport Code System (PHITS [A])

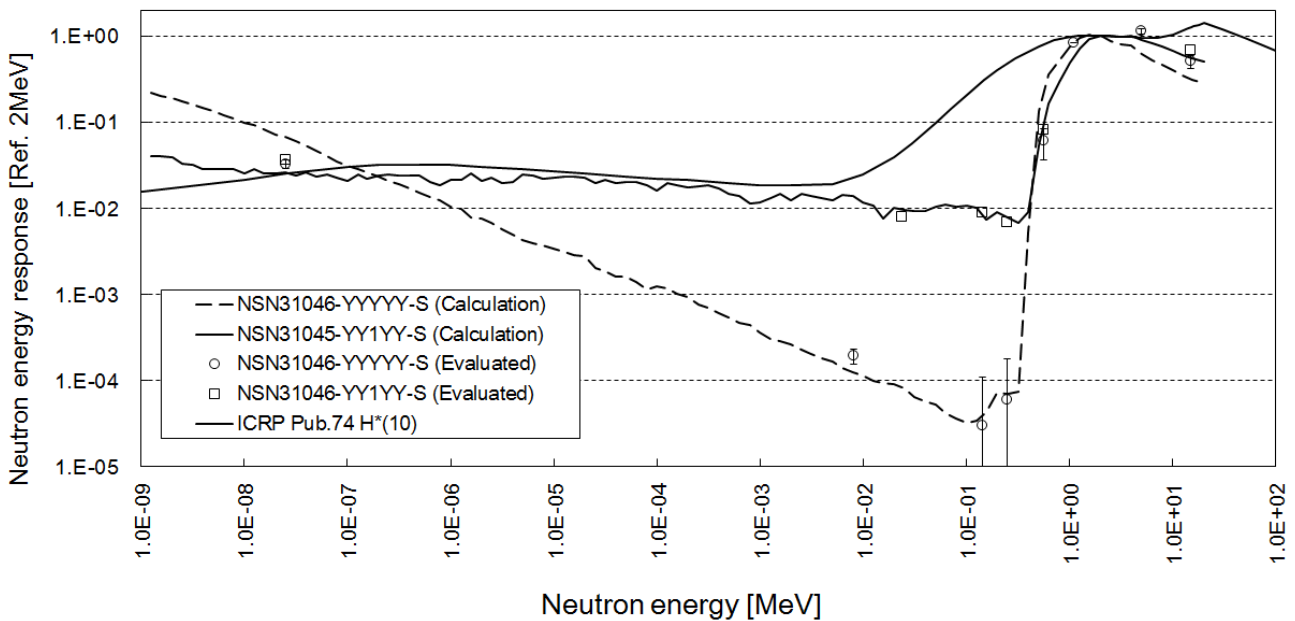

Figure 9-2-2 Energy characteristics for monoenergetic neutrons

[A] T. Sato et al., "Particle and Heavy Ion Transport Code System PHITS", Version 2.52, J. Nucl. Sci. Technol. 50:9, 913-923 (2013)

### 9.3 Response for photon radiation

Table 9-3 Response for photon radiation

Gamma-ray ( $^{137}\text{Cs}$ ) Reference dose equivalent late [mSv/h]	Indication [mSv/h]	Response [%]
1	< 0.0001	< 0.01 %
10	< 0.01	< 0.1 %

### 9.4 Angular dependence

#### 9.4.1 Horizontal direction

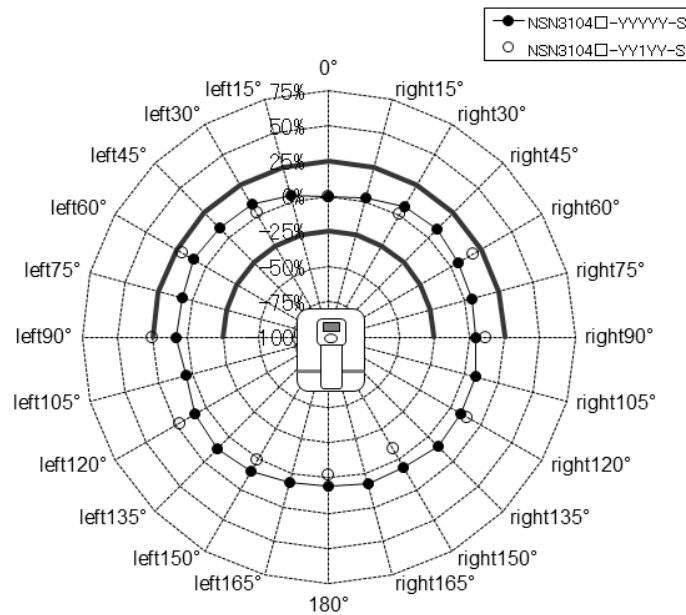

#### 9.4.2 Vertical direction

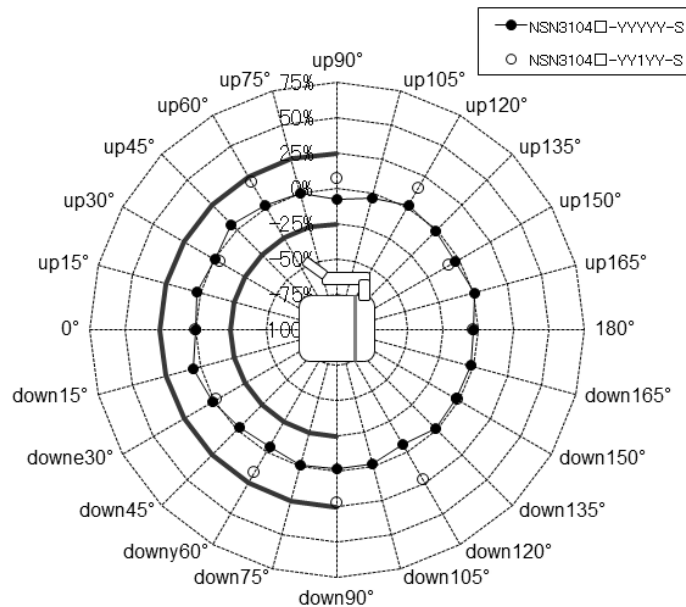

## 10. Appendix B Error code

When communication error occurs, the following error code will be displayed on the screen. Refer to Table 10-1 for further details.

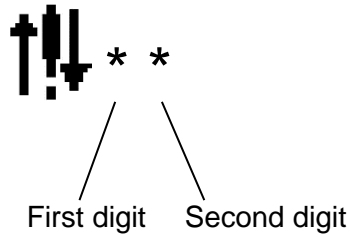

Table 10-1 Error code

First digit indicates the location where the error occurred.	Second digit indicates details of error (*)
0 : PC 1 : NHV1 (Display) 2 : <b>NSN3</b> (Detector)	0 : RAS failure when start-up 1 : BCC failure 2 : Communication failure Overrun error Framing error Parity error 3 : Sequence number failure 4 : BYTEN failure of received data 5 : Format failure 6 : Time out error of received data 7 : Received multi-request signal 8 : Power supply failure 9 : EEPROM failure

### NOTE (\*):

RAS: Reliability, Availability and Serviceability  
 BCC: Binary Code Check  
 EEPROM: Electrically-Erasable Programmable Read-Only Memory

## 11. Appendix C Confirmation of dose rate response

This section describes the calibration procedures for the **NSN3**. Expose the **NSN3** to the neutron sources such as  $^{252}\text{Cf}$  and  $^{241}\text{Am-Be}$ . A dose rate should be measured by placing the source at the distance from reference point of the **NSN3** and it should also be traceable to the Japanese National Standard.

In general, if many instruments require the calibration on site, then the calibration can be done by comparing a working standard (**NSN3**) that has been calibrated by the accredited calibration laboratory.

Before calibration of the neutron survey meter, correction factor should be changed to "1.00" on operation setting screen.

### (1) Determination of a reference dose rate value ( $R_0$ )

- Determine a reference dose rate value ( $R_0$ ) by the following either a or b.
  - a. Calculate  $R_0$  from the distance between the reference source and reference point of the **NSN3**.
  - b. After purchase, place the source at the distance from the reference point of the **NSN3** and take reading,  $R_0$ .

### (2) Dose rate Value ( $R_1$ ) Measurement

- Place the source such as  $^{252}\text{Cf}$  and  $^{241}\text{Am-Be}$  at the distance from reference point of the **NSN3**.
- Take the dose rate reading ( $R_1$ ).

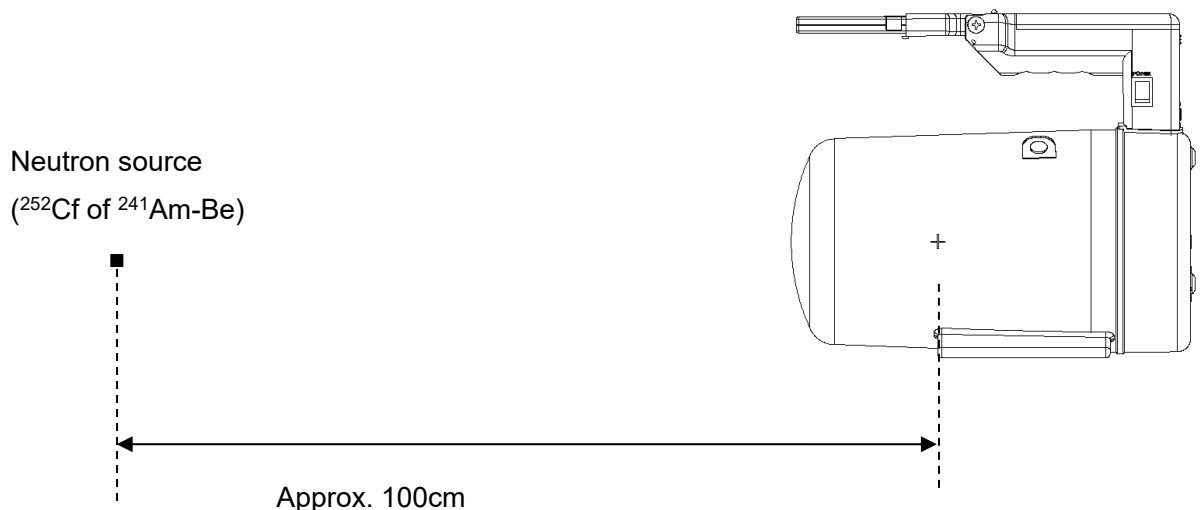

Figure 11-1 Geometrical conditions

### (3) Calculation of the calibration factor

- Compare the reference dose rate ( $R_0$ ) and the dose rate reading ( $R_1$ ). If there is an unacceptable difference between  $R_0$  and  $R_1$ , change the calibration factor.

In general, the calibration factor ( $C_1$ ) is calculated by the following formula:

$$C_1 = C_0 \times R_0/R_1$$

$C_0$ : Original calibration factor

### (4) Setup of the calibration factor

- To change the calibration factor, prepare the following items:
  - Personal Computer (Windows OS).
  - USB cable (optional).
  - Maintenance software (optional).
- Install the maintenance software.
- Connect the PC to the display unit of the **NSN3** using the USB cable.

Note: Connect to the PC only with the display unit attached to the main body.

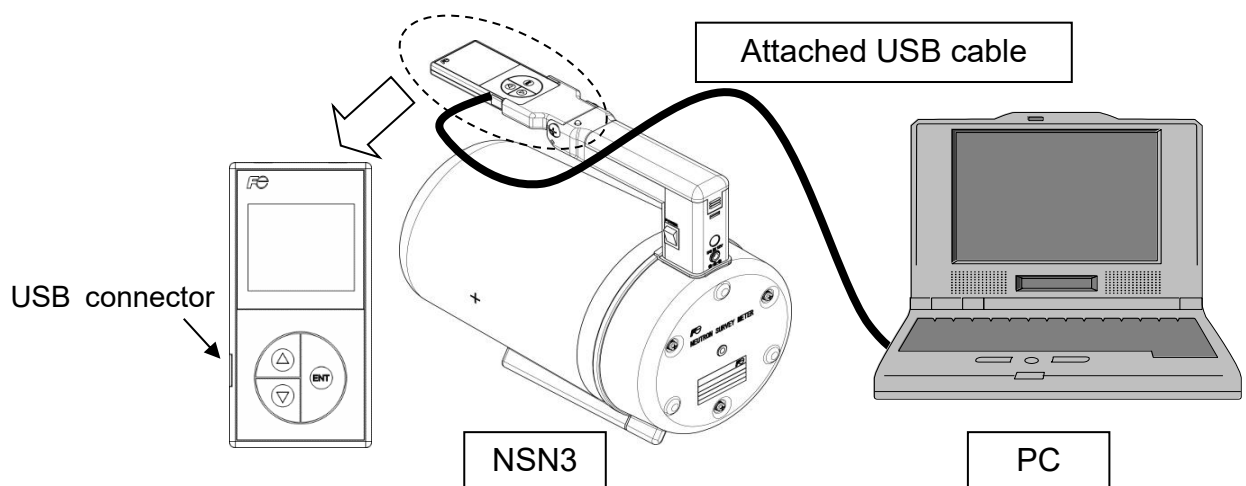

Figure 11-2 System configuration for the data transfer

- The maintenance software activates and then the following "Main Menu" is displayed.

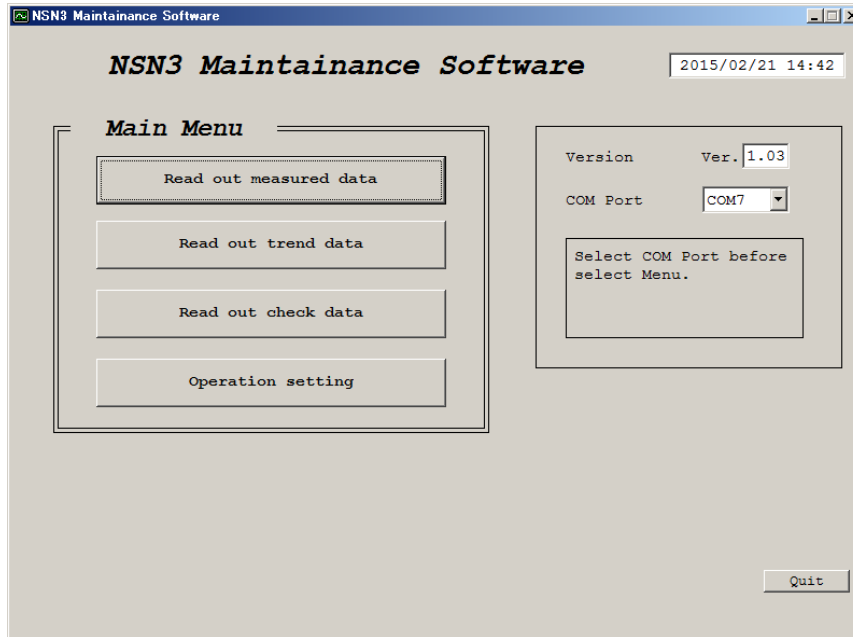

Figure 11-3 Main menu screen

- Click on the "Operation setting" under the "Main Menu". Confirm that the "Operation setting" screen is displayed as shown below.

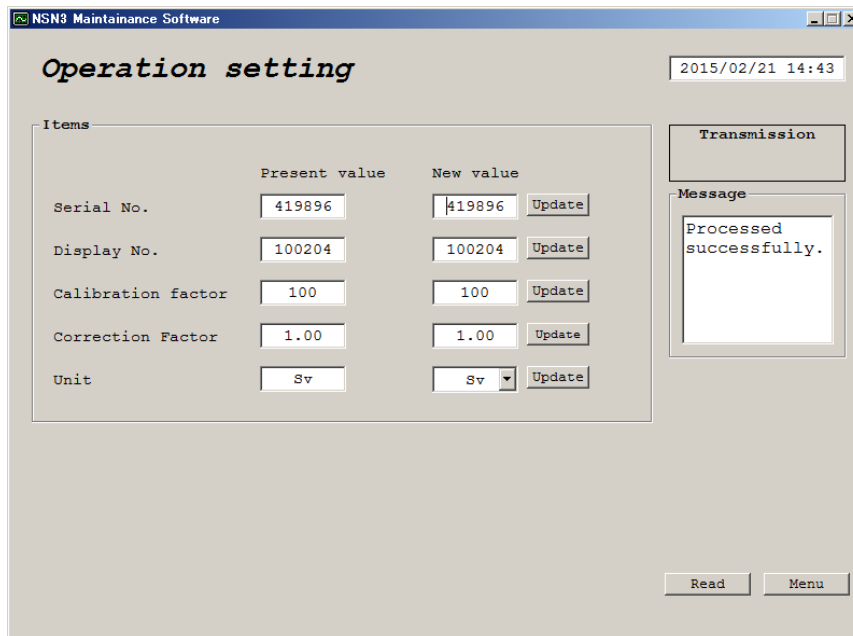

Figure 11-4 Operation setting screen

- Click on "Read" to display the calibration factor.

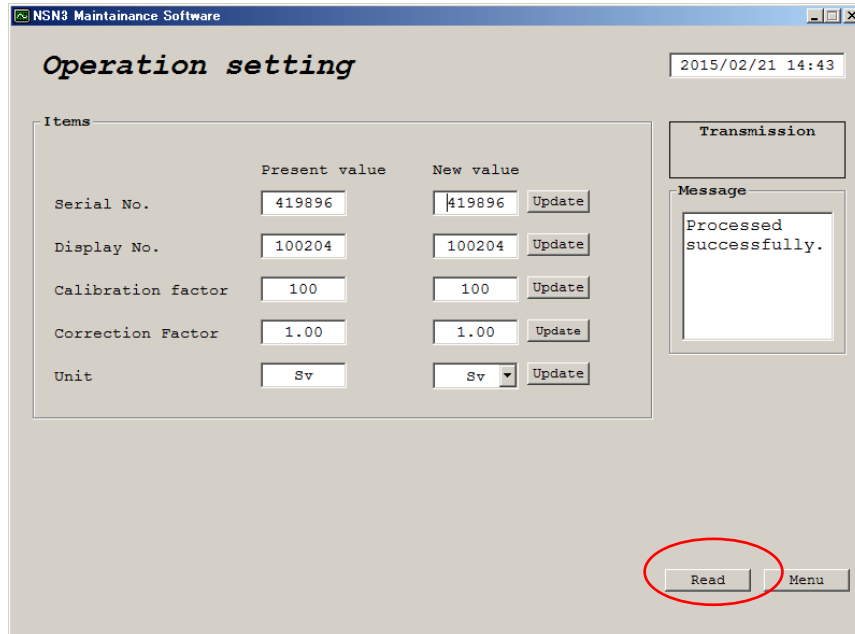

Figure 11-5 Operation setting screen

- Enter the calibration factor value and then click on "Update" as shown below. For example, when changing the calibration factor to 1.28, then enter "128".

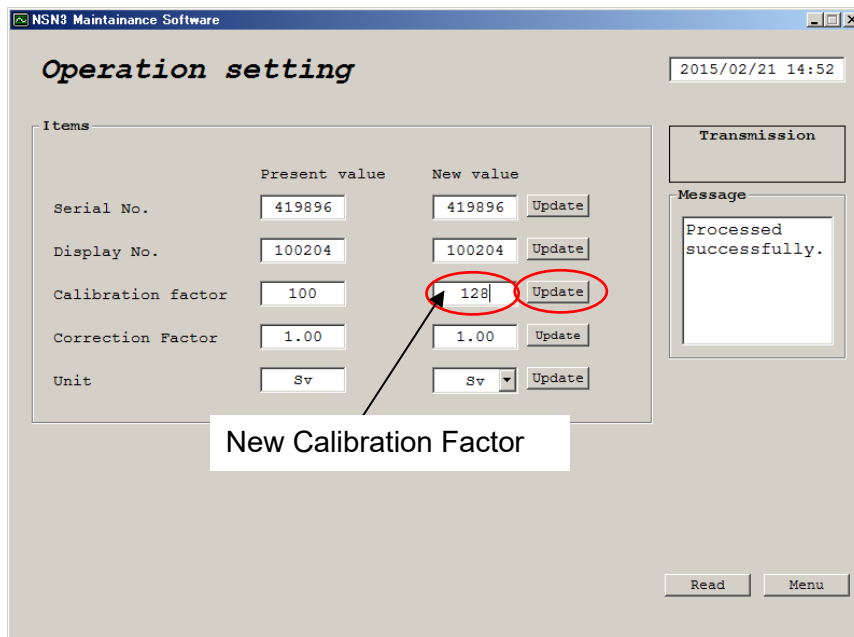

Figure 11-6 Operation setting screen

- Click on "Read" again and confirm that the calibration factor is updated.

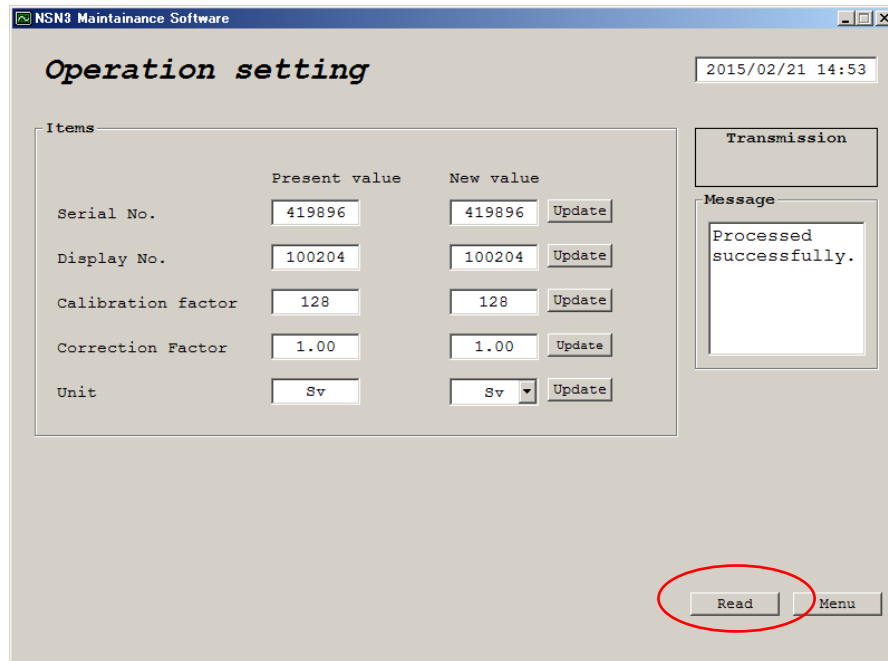

Figure 11-7 Operation setting screen

## 12. Appendix D Transportation

This section describes the packing and transportation method for this product. Shipping should be performed by shipper's responsibility.

Because the following dangerous materials are included, shipper shall pack and transport according to this chapter.

United Nations Number	:	UN1954
Proper Shipping Name (PSN)	:	Compressed gas, flammable, n.o.s. (Methane/Nitrogen mixture)
Class	:	Gases
Division	:	2.1 Flammable Gas
Pressure in vessel	:	506.6 kPa
Weight of gas	:	Net 0.006kg
Weight of the product	:	approximately 3.5 kg
Packing instruction	:	PI200

(This instruction is defined in the "IATA Dangerous Goods Regulations")

## 12.1 Packing method

This section describes the packing method for this product. The packing must be performed according to U.S. DOT special permit (DOT-SP 16217). It is recommended that dedicated optional packaging material (transportation case or fiberboard box) is used for the packaging of this product since they were tested and confirmed the compliance with U.S. DOT special permit (DOT-SP 16217).

### 12.1.1 Packing methods using the transportation case

- 1) Main material : Plastic Box
- 2) Case model : Pelican 1600
- 3) Packing method
  - i) Put main body of neutron survey meter and accessories in the form material in the Pelican 1600 case.  
See attached example for appropriate product layout in the case.

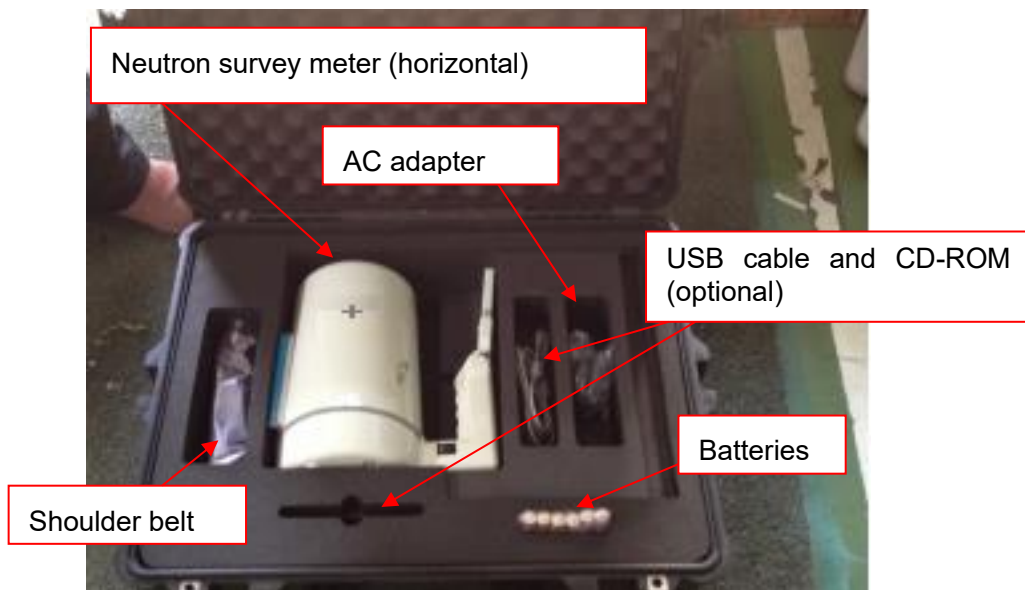

- ii) Close the transportation case and lock the fixture around the case.

### 12.1.1 Packing methods using the cardboard box for transportation

1) Material

- Main Material : Fiberboard box
- Dimension : 590mm(L) x 390mm(W) x 310mm(H)
- Inner Material : Styrofoam
- Buffer materials: Eco plus etc.
- Packing Tape : 45mm or more width with sufficient adhesive power

2) Packing method

- i) Seal off the bottom surface of the Fiberboard box by taping all lids together in H-shaped form.

Tape all lids in H-shaped form.

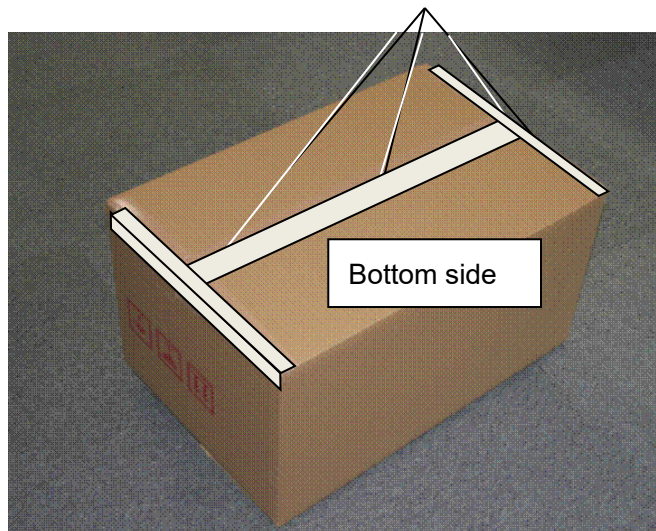

- ii) Put in the inner material for neutron survey meter to fiberboard box.
- iii) Place the neutron survey meter and buffer materials like following figure.

Body of the neutron survey meter (Horizontal)

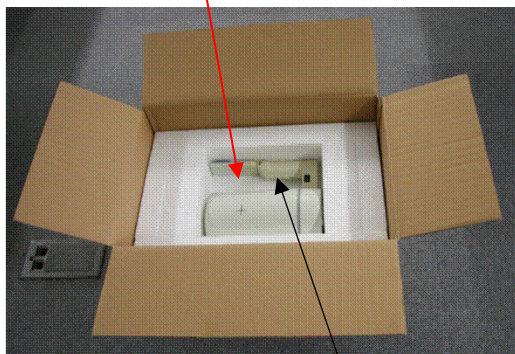

Buffer materials



Caution : To avoid damage to the handle, DO NOT put a load on the handle part.  
DO NOT put an urethane and etc. forcefully between the handle and the body.

- iv) Put in the inner material for accessories on the inner material for neuron survey meter.
- v) Place the accessories and buffer materials like following figure.

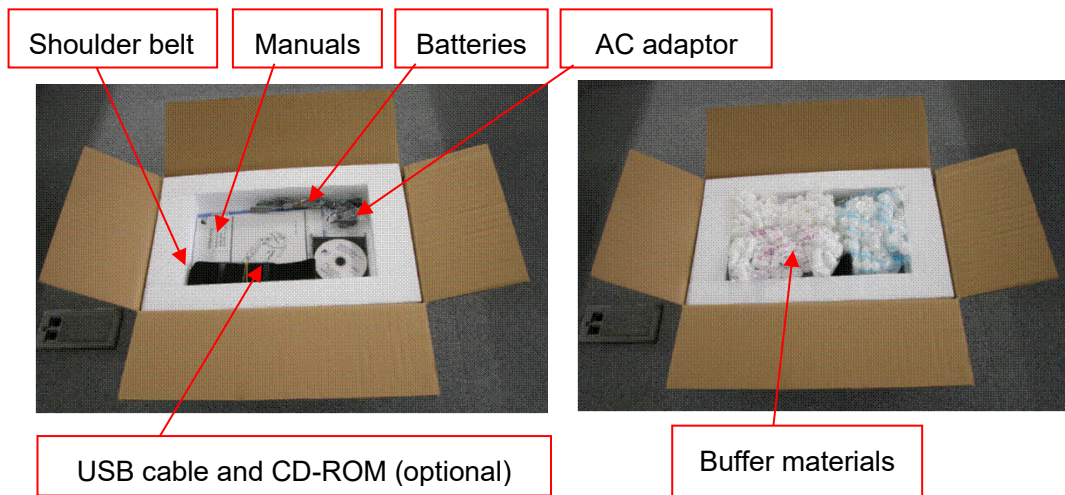

- vi) Seal off the top surface of the cardboard case by taping all lids together in H-shaped form.

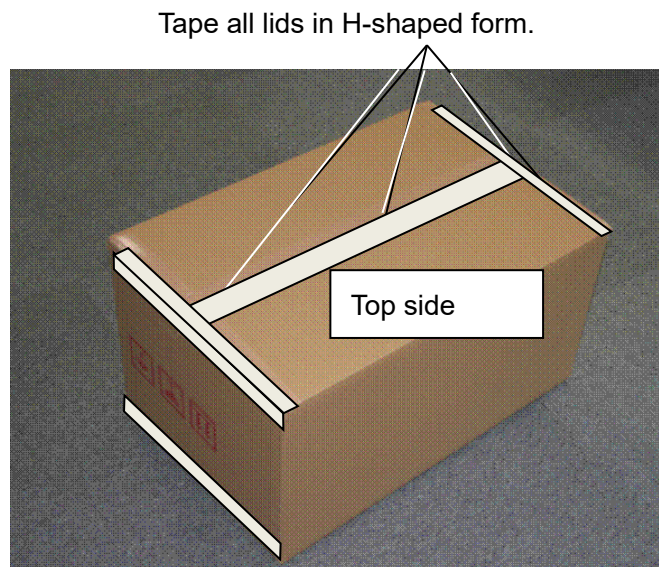

## 12.2 Transportation method

### 1) Ground transportation

Transport this product according to the regulations of the applicable country.

This neutron survey meter can be transported with usual ground transportation service in Japan since any Japanese regulations does not prohibit or limit a ground transportation of this product. For the ground transportation in the U.S., transport this product according to special permit (DOT-SP 16217)

### 2) Air transportation

Transport this product according to special permit (DOT-SP 16217) and IATA (International Air Transport Association) regulations.

Only cargo aircraft is acceptable.

Submit the declaration of hazardous materials in order to declare the materials contained in this product to the forwarder and/or the airline operator. Also, submit special permit as needed or on request by the airline operator.

Discuss with the forwarder and/or airline operator and make the necessary marking on the package. In addition, attach the following labels.

Dangerous Goods label : "Flammable Gas"

Handling label : "Cargo Aircraft Only"

For the air transportation in the U.S., transport this product according to special permit.

### 3) Marine transportation

If marine transportation is needed, please contact the applicable country's authority.

Marine transportation is not permit in the U.S.

The copy of U.S. special permit mentioned above is attached in section 12.3. But please confirm the latest special permission by all means. The latest special permit available by accessing the following "Hazardous Materials Safety" website.

<https://www.phmsa.dot.gov/approvals-and-permits/hazmat/special-permits-search>

or

<https://www.phmsa.dot.gov/approvals-and-permits/hazmat/file-serve/offer/SP16217.pdf/offerserver/SP16217>

Photo reproductions and legible reductions of this special permit are permitted. Any alteration of this special permit is prohibited.

### 12.3 Special permit

See following special permit. Please get the latest special permit and confirm it before shipping.

**June 10, 2024**



U.S. Department  
of Transportation

**Pipeline and Hazardous  
Materials Safety  
Administration**

1200 New Jersey Avenue, SE  
Washington, DC 20590

DOT-SP 16217  
(FOURTH REVISION)

**EXPIRATION DATE: 2028-05-31**

(FOR RENEWAL, SEE 49 CFR 107.109)

1. GRANTEE: Fuji Electric Co., Ltd.  
Shinagawa-ku, Tokyo, Japan  
  
US AGENT: SME Associates LLC  
Palmetto, FL
2. PURPOSE AND LIMITATIONS:
  - a. This special permit authorizes the manufacture, mark, sale and use of a neutron radiation detector containing a Division 2.1 flammable gas. This special permit provides no relief from the Hazardous Materials Regulations (HMR) other than as specifically stated herein. The most recent revision supersedes all previous revisions.
  - b. The safety analyses performed in development of this special permit only considered the hazards and risks associated with transportation in commerce. The safety analyses did not consider the hazards and risks associated with consumer use, use as a component of a transport vehicle or other device, or other uses not associated with transportation in commerce.
  - c. In accordance with 49 CFR 107.107(a) party status may not be granted to a manufacturing permit. These packagings may be used in accordance with 49 CFR 173.22a.
3. REGULATORY SYSTEM AFFECTED: 49 CFR Parts 106, 107 and 171- 180.
4. REGULATIONS FROM WHICH EXEMPTED: 49 CFR § 173.310 in that a Division 2.1 material is not authorized, except as provided herein.

Tracking Number: 2024044938

TN5A3974g

72/77

5. **BASIS:** This special permit is based on the application of Fuji Electric Co., Ltd. dated May 7, 2024, and submitted in accordance with § 107.109.
6. **HAZARDOUS MATERIALS (49 CFR § 172.101):**

<b>Hazardous Material Description</b>			
<b>Proper Shipping Name</b>	<b>Hazard Class/ Division</b>	<b>Identification Number</b>	<b>Packing Group</b>
Compressed gas, flammable, n.o.s.	2.1	UN1954	N/A

7. **SAFETY CONTROL MEASURES:**

- a. **PACKAGING:** Prescribed packagings are non-DOT specification, hermetically sealed, non-refillable welded cylinders which are components of Fuji Electric Co., Ltd. Neutron Survey Meters, a neutron radiation detector. The design burst pressure of each cylinder must be at least four times the maximum operating pressure (service pressure). The cylinders must be manufactured in accordance with the design specifications and drawings in Fuji Electric Co., Ltd.'s application on file with the Office of Hazardous Materials Safety (OHMS) and with the following:

Cylinder volume: 1.5 liters (0.4 gallons)  
 Maximum operating pressure (service pressure): 0.4 MPa (58 psig).  
 Material: Stainless steel

b. **OPERATIONAL CONTROLS:**

- (1) Each cylinder must be shipped in a strong outer packaging capable of withstanding a drop test of at least 1.8 meters (6 feet) without breakage of the radiation detector or rupture of the outer packaging.
- (2) If repackaged, packagings used to ship larger equipment containing radiation detectors covered by this special permit must be in strong outside packagings providing equivalent protection for the devices as specified in paragraph 7.b.(1) above.
- (3) Emergency response information provided with the shipment and available via an emergency response telephone number must identify those cylinders that are not fitted with pressure relief devices and provide appropriate guidance for exposure to fire.

8. SPECIAL PROVISIONS:

a. In accordance with the provisions of Paragraph (b) of § 173.22a, persons may use the packaging authorized by this special permit for the transportation of the hazardous materials specified in paragraph 6, only in conformance with the terms of this special permit.

b. A person who is not a holder of this special permit, but receives a packaging covered by this special permit, may reoffer it for transportation provided no modification or change is made to the packaging and it is offered for transportation in conformance with this special permit and the HMR.

c. A current copy of this special permit must be maintained at each facility where the package is offered or reoffered for transportation.

d. Each packaging manufactured under the authority of this special permit must be either (1) marked with the name of the manufacturer and location (city and state) of the facility at which it is manufactured or (2) marked with a registration symbol designated by the Office of Hazardous Materials Special Permits and Approvals for a specific manufacturing facility.

e. A current copy of this special permit must be maintained at each facility where the packaging is manufactured under this special permit. It must be made available to a DOT representative upon request.

f. Except when offered for transportation by air:

(1) Packages covered by this special permit are excepted from the labeling requirement of Subpart E of 49 CFR Part 172.

(2) Shipments are not subject to the placarding requirements of Subpart F of 49 CFR Part 172.

9. MODES OF TRANSPORTATION AUTHORIZED: Motor vehicle, cargo aircraft, and rail freight.

10. MODAL REQUIREMENTS: A current copy of this special permit must be carried aboard each aircraft or motor vehicle used to transport packages covered by this special permit. The shipper must furnish a copy of this special permit to the air carrier before or at the time the shipment is tendered.

11. **COMPLIANCE:** Failure by a person to comply with any of the following may result in suspension or revocation of this special permit and penalties prescribed by the Federal hazardous materials transportation law, 49 U.S.C. 5101 et seq.:
- o All terms and conditions prescribed in this special permit and the Hazardous Materials Regulations, 49 CFR Parts 171-180.
  - o Persons operating under the terms of this special permit must comply with the security plan requirement in Subpart I of Part 172 of the HMR, when applicable.
  - o Registration required by § 107.601 et seq., when applicable.

Each "Hazmat employee", as defined in § 171.8, who performs a function subject to this special permit must receive training on the requirements and conditions of this special permit in addition to the training required by §§ 172.700 through 172.704.

No person may use or apply this special permit, including display of its number, when this special permit has expired or is otherwise no longer in effect.

Under Title VII of the Safe, Accountable, Flexible, Efficient Transportation Equity Act: A Legacy for Users (SAFETEA-LU)—“The Hazardous Materials Safety and Security Reauthorization Act of 2005” (Pub. L. 109-59), 119 Stat. 1144 (August 10, 2005), amended the Federal hazardous materials transportation law by changing the term “exemption” to “special permit” and authorizes a special permit to be granted up to two years for new special permits and up to four years for renewals.

**June 10, 2024**

12. **REPORTING REQUIREMENTS:** Shipments or operations conducted under this special permit are subject to the Hazardous Materials Incident Reporting requirements specified in 49 CFR §§ 171.15 - Immediate notice of certain hazardous materials incidents, and 171.16 - Detailed hazardous materials incident reports. In addition, the grantee(s) of this special permit must notify the Associate Administrator for Hazardous Materials Safety, in writing, of any incident involving a package, shipment or operation conducted under terms of this special permit.

Issued in Washington, D.C.:

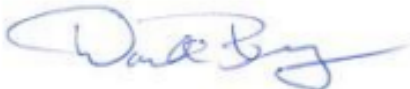

for William Schoonover  
Associate Administrator for Hazardous Materials Safety

Address all inquiries to: Associate Administrator for Hazardous Materials Safety, Pipeline and Hazardous Materials Safety Administration, U.S. Department of Transportation, East Building PHH-13, 1200 New Jersey Avenue, Southeast, Washington, D.C. 20590.

Copies of this special permit may be obtained by accessing the Hazardous Materials Safety Homepage at <https://www.phmsa.dot.gov/approvals-and-permits/hazmat/special-permits-search>. Photo reproductions and legible reductions of this special permit are permitted. Any alteration of this special permit is prohibited.

PO: Jephthah Nti

