

# PORTABLE TYPE ULTRASONIC FLOWMETER

DATA SHEET

FSC-5, FSS

Portable type ultrasonic flowmeter consists of a compact and lightweight flow transmitter and a clamp-on detector. With the latest electronics and the digital signal processing technology, it delivers precise measurement while allowing easy operation.

## FEATURES

### 1. Battery operation

The flowmeter is designed for 12 hours of continuous operation via built-in battery.

### 2. Full variety of detectors

The flowmeter is suitable for various types of detectors applicable for small to large diameter pipe (pipe inner diameter  $\phi 13$  to  $\phi 6000$ mm) and low to high temperature ( $-40$  to  $+200^{\circ}\text{C}$ ).

### 3. High accuracy and high-speed response

The flowmeter is designed for high accuracy ( $\pm 1.0\%$ ). Response time is within 1 second.

### 4. Improved anti-bubble characteristic

Anti-bubble characteristic is greatly improved by digital signal processing.

### 5. Excellent performance and easy operation

Graphic LCD that is outside but easy to read. Minimum number of function keys are used for page selection, allowing easy setting. While battery is working, the flowmeter is water resistant and tolerates exposure to rain.

### 6. Large capacity storage by SD memory card

Measured data is periodically stored in SD memory card. In the case of 512MB (option), it can be saved about 2 year measurement date (In case of saving period 30 seconds, 14 kinds of saved data). Available up to 32GB.

### 7. Serial communication

Use of a USB port allows easy connection to a personal computer. Measured data collection panel and Loader software for PC (standard) which is available for display and change of parameter (site setting) are prepared.

### 8. Heat quantity (calorie) measurement

Heat quantity (calorie) may be measured by temperature input, making energy management easy for cooling and heating.

## SPECIFICATIONS

### Measuring objects

#### Measurement fluid:

Uniform liquid in which ultrasonic waves can propagate.

Turbidity of fluid: 10000 mg/L or less



Flow transmitter (FSC)



Detector (FSSC)



Large diameter type (FSSE)

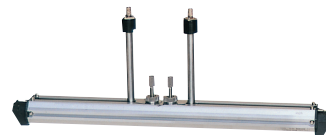

High-temperature type (FSSH)

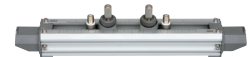

Small diameter type (FSSD)

**State of fluid:** Well-developed turbulent or laminar flow in a filled pipe.

**Fluid temperature:**  $-40$  to  $+200^{\circ}\text{C}$

**Measuring range:**  $0 \cdots \pm 0.3$  to  $\pm 32$ m/s

### Piping conditions

#### Applicable piping material:

Select from carbon steel, stainless steel, cast iron, PVC, FRP, copper, aluminum, acrylic or material of known sound velocity.

**Pipe size:** Flow rate measurement  
 $\phi 13$  to  $\phi 6000$ mm

**Lining material:** Select from no lining, tar epoxy, mortar, rubber, Teflon, pyrex glass or material of known sound velocity.

Note) No gap allowed between the lining and the pipe.

#### Straight pipe length:

10D or more upstream and 5D or more downstream (D: internal pipe diameter)  
Refer to Japan Electric Measuring Instruments Manufacturers' Association's standard JEMIS-032 for details.

**Performance specifications**

**Accuracy rating:**

Pipe inner diameter	Flow velocity range	Accuracy (Note2)
ø13 to ø50mm	2 to 32m/s	±1.5% to 2.5% of rate
	0 to 2m/s	±0.03m/s
ø50 to ø300mm	2 to 32m/s	±1.0% to 1.5% of rate
	0 to 2m/s	±0.02 to 0.03m/s
ø300 to ø6000mm	1 to 32m/s	±1.0% to 1.5% of rate
	0 to 1m/s	±0.01 to 0.02m/s

Note1) Reference conditions are based on JEMIS-032.  
 Note2) Refer to the 4 pages for the accuracy according to kind of detector.

**Flow transmitter (Type: FSC)**

**Power supply:** Built-in battery or AC power adapter  
 Built-in battery: Exclusive lithium button battery (7.2V)  
 Continuous operation time, approx. 12 hours (back light OFF, output current not used and at normal ambient temperature (20°C))  
 Recharging time, approx. 3 hours (power adapter used, with 20°C)  
 Recharging temperature range: 0 to +40°C  
 Power consumption: 3W  
 The consumption varies depending on the use conditions.

Power adapter: Exclusive power adapter 100V to 240V +10%/–15% AC (50/60Hz), 90VA or less.

**Display:** TFT color graphic LCD  
 240 × 320 (with back light)  
 Measurement value (instantaneous flow rate, integrated flow rate) and various settings are displayed.  
 Excellent visibility even outdoors in direct sunlight.

**LED display:** Status display when using AC power adapter.  
 DC IN (green): Power supply status  
 CHARGE (red): Battery charging underway

**Operation keypad:**  
 11 buttons  
 (ON, OFF, ENT, ESC, MENU, △, ▽, ◀, ▶, LIGHT, SCREEN SHOT)

**Power failure backup:**  
 Measurement value is backed up by nonvolatile memory.  
 Clock backup with lithium battery (effective term, 10 years or more)

**Response time:** 1 second

**Analog output signals:**  
 4 to 20mA DC, one point (load resistance, 600Ω or less)  
 Instantaneous velocity, instantaneous flow rate or heat quantity (calorie) after scaling.

**Analog input signal:**  
 4 to 20mA DC, one point (input resistance, 200Ω or less)  
 4 to 20mA DC, one point (input resistance, 200Ω or less)  
 or 1 to 5V DC, one point  
 Used to input temperature for heat quantity measurement, etc.

Total 2 points

**SD memory card:** Used for data logger function and recording screen data.  
 Available up to 32GB (Option256MB)  
 Compliant media  
 • SD memory card: speed class 2, 4, 6  
 • SDHC memory card: speed class 4, 6  
 Note) The SDXC memory card is not supported

**Format**  
 • FAT16: 64MB to 2GB  
 • FAT32: 4GB, 8GB, 16GB, 32GB  
 Otherwise, reading and saving are impossible.  
**File format**  
 • Date logger: CSV file  
 • Screen date: Bit map file

**Serial communication:**  
 USB port (device\* compatible):  
 Mini B receptacle, USB 2.0  
 Connectable number of Mini B receptacles:  
 1 unit  
 Transmission distance: 3m max.  
**Data:**  
 Instantaneous velocity, instantaneous flow rate, total value, heat quantity (calorie) value, error information, logger data, etc.  
 \* Device: Connected plug from PC

**Ambient temperature:**  
 –10 to +55°C

**Ambient humidity:** 90%RH or less

**Type of enclosure:** IP64

**Enclosure case:** Plastic case

**Outer dimensions:** H210 × W120 × D65mm

**Weight:** 1.0kg

**Functions**

**Display language:** Selectable from Japanese, English, German, French, Spanish or Chinese (switchable by key operation).

**Clock display function:**  
 Time (year, month, day, hour, minute) display (configurable)  
 Monthly error: about 1 minutes at normal temperature (20°C).

**Instantaneous value display function:**  
 Instantaneous velocity, instantaneous flow rate display (The flow in reverse direction is displayed with minus “-.”)  
 Numeric value: 10 digits (decimal point equals 1 digit)  
 Unit: Metric/English system selectable  
 Metric system  
 Velocity: m/s  
 Flow rate: L/s, L/min, L/h, L/d, kL/d, ML/d, m³/s, m³/min, m³/h, m³/d, km³/d, Mm³/d, BBL/s, BBL/min, BBL/h, BBL/d, kBBL/d, MBBL/d  
 English system  
 Velocity: ft/s  
 Flow rate: gal/s, gal/min, gal/h, gal/d, kgal/d, Mgal/d, ft³/s, ft³/min, ft³/h, ft³/d, kft³/d, Mft³/d, BBL/s, BBL/min, BBL/h, BBL/d, kBBL/d, MBBL/d

**Total value display function:**

Display of forward or reverse total (reverse is displayed as minus)  
 Numeric value: 10 digits (decimal point is corresponding to 1 digit)  
 Unit: Metric/English system selectable  
 Metric system  
 Flow rate total: mL, L, m<sup>3</sup>, km<sup>3</sup>, Mm<sup>3</sup>, mBBL, BBL, kBBL  
 English system  
 Flow rate total: gal, kgal, ft<sup>3</sup>, kft<sup>3</sup>, Mft<sup>3</sup>, mBBL, BBL, kBBL, ACRE-ft

**Consumed heat quantity (calorie) display function:**

Display of consumed heating medium  
 Metric system  
 Heat flow: MJ/h, GJ/h  
 Total heat quantity: MJ, GJ  
 English system  
 Heat flow: MJ/h, GJ/h, BTU/h, kBTU/h, MBTU/h, kW, MW  
 Total heat quantity:  
 MJ, GJ, BTU, kBTU, MBTU, kWh, MWh  
 J : Joule  
 BTU : British thermal unit  
 W : Watt

**Computation function of consumed heat quantity (calorie):**

This function calculates the heat quantity received and sent with liquid (water) in cooling and heating.

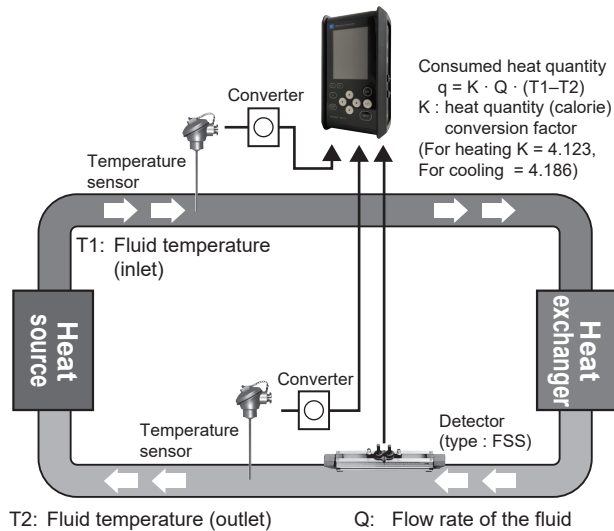

**Temperature display function:**

Fluid temperature be displayed by current input from temperature transmitter.  
 Metric system  
 Temperature unit: °C or K  
 English system  
 Temperature unit: °F or K

**Site data storage function:**

Max. 32 locations (sites) data (pipe size, material, fluid type and etc) can be stored into built-in non-volatile memory.

**Damping:**

0 to 100sec (every 0.1sec) configurable for analog output and velocity/flow rate display

**Low flow cut:**

Equivalent to 0 to 5m/s

**Output setting function:**

Current output scaling, output type, burnout setting and calibration

**Serial communication function:**

Instantaneous velocity, instantaneous flow rate, total value, heat flow, error information, received waveform, analog input, logger data, etc. may be downloaded to personal computer.

**Logger function:** Instantaneous velocity, instantaneous flow rate, total value, heat flow, error information, received waveform, analog input, can be saved in a SD memory card.

**Waveform display function:**

Bi-directional received waveforms may be displayed.

**Graph display function:**

Flow rate trend graph may be displayed.

**Detector (Type: FSS)**

**Type of detector:**

Classification	Type	Internal pipe diameter (mm)	Fluid temperature	Frequency (MHz)
Middle diameter	FSSC	ø50 to ø1200 <sup>(*)</sup>	-40 to 120°C	1
Small diameter	FSSD	ø13 to ø300	-40 to 100°C	2
Large diameter	FSSE	ø200 to ø6000	-40 to 80°C	0.5
High temperature	FSSH	ø50 to ø400	-40 to 200°C	2

\*1) For pipes with a diameter of 300 mm or larger, we recommend to use FSSE and mount it by Z method.

**Mounting method:** Mounting on outside of pipe

**Sensor mounting method:** V or Z method

**Signal cable:** Exclusive coaxial cable, 5m (Included with FSC)

**Connection method:**

Transmitter side: Exclusive connector  
 Detector side (FSSE): Screw terminal  
 Others: BNC connector

**Ambient temperature:** -20 to +60°C

**Ambient humidity:**

FSSE 100%RH or less  
 Other 90%RH or less

**Type of enclosure:**

FSSC IP65  
 (When waterproof BNC connector is provided)  
 FSSE IP67  
 Others IP52  
 Water-proof treatment type IP68  
 (Submerged resistant structure for 5 days)

**Material of detector:**

Classification	Type	Sensor case	Rail material
Small diameter	FSSD	Plastic	Aluminum alloy + Plastic
Middle diameter	FSSC	Plastic	Aluminum alloy + Plastic
Large diameter	FSSE	Plastic	—
High temperature	FSSH	SUS304	Aluminum alloy

**Material of mounting belt/wire:**

Detector type 6th digit	Dimensions	Material
A	1.5mX2	SUS304
B	3.0mX1	Plastic cloth belt
C	1.0mX4	SUS304
D	Inner pipe diam.<ø1500mm	SUS304
E	Inner pipe diam.<ø6000mm	SUS304

**Extension cable(option):**

Extended when the length of the detector signal cable is not sufficient.  
 Length: 10m, 50m

## MEASURING PRINCIPLE

With ultrasonic pulses propagated diagonally between the upstream and downstream sensors, flow rate is measured by detecting the time difference obtained by the flow of fluid.

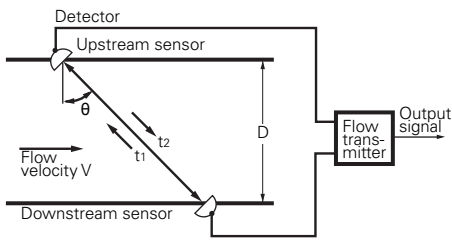

## MOUNTING OF DETECTOR

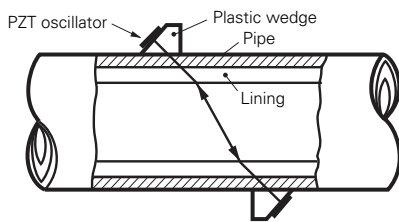

## CONFIGURATION DIAGRAM

(1) When V method is used for mounting

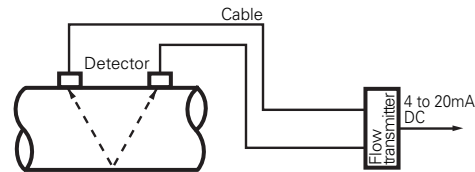

(2) When Z method is used for mounting

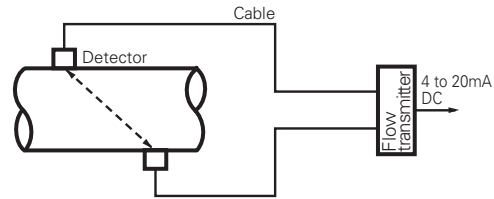

## DETECTOR SELECTION GUIDE (ACCURACY % of rate)

TYPE	Mounting method	Inner diameter of piping $\phi$ [mm]													
		13	25	50	100	150	200	250	300	400	600	1200	3000	6000	
FSSD	V <sup>(2)</sup>			$\pm 1.5$ to 2.5					$\pm 1.0$						
	Z <sup>(1)</sup>							$\pm 1.0$							
FSSC	V					$\pm 1.5$			$\pm 1.0$						
	Z							$\pm 1.0$							
FSSE	V								$\pm 1.5$			$\pm 1.0$			
	Z								$\pm 1.5$			$\pm 1.0$			
FSSH	V							$\pm 1.0$							
	Z <sup>(1)</sup>							$\pm 1.0$							

\*1) When FSSD or FSSH is mounted using the Z method, guide rail (option) is required additionally.

\*2) For the pipe inner diameter of  $\phi 13$ mm, the sensor mounting dimension may be 0.0mm or less depending on pipe material and thickness. When the sensor mounting dimension is 0.0mm or less, measurement error is about 2 to 5%.

Required min. pipe thickness (fluid: water) (Unit: mm)			
Steel pipe	2.15 or more	FRP	3.21 or more
Stainless pipe	1.87 or more	Ductile cast iron	2.15 or more
PVC pipe	3.69 or more	PEEK	3.69 or more
Copper pipe	3.82 or more	PVDF	3.69 or more
Cast-iron pipe	2.98 or more	Acrylic pipe	2.90 or more
Aluminum pipe	1.99 or more	Polypropylene	3.69 or more

<Description of the table>

It shows pipe thickness of each material that the sensor mounting size is to be 0.0mm, when fixing a pipe. If the fluid is the one other than water, and if the sound velocity of fluid is faster than the one of water, the sensor mounting size is to be 0.0mm or more.

## PC Loader Software

You can download the software from Fuji Electric's product website.

The loader software is not covered by the quality guarantee..

- PC: PC/AT compatible machine
- Main functions: Display and change of parameters (site settings) of the main unit and collection of measurement data, including instantaneous velocity, instantaneous flow rate, total value, error information, wave receiving level, analog input, and logger data.
- Operating system (tested): Windows 11
- Memory capacity: 128 MB or more
- Free hard disc capacity: 52 MB or more
- Interface: USB 2.0

## EU Directive Compliance



### EMC (2014/30/EU)

- EN 61326-1 (Table 2)
- EN 55011 (Group 2, Class A)
- EN 61000-3-2 (Class A)
- EN 61000-3-3
- EN 61326-2-3

### RoHS (2011/65/EU+(EU)2015/863)

- EN IEC 63000: 2018

## CODE SYMBOL

### <Flow transmitter>

1	2	3	4	5	6	7	8	9	10	11	Description
F	S	C	S	1	0	5	-	0			<Specification> Standard
			S								<Converter> Basic system
				1							<Power adapter> AC power + power cord (125V AC) for Japanese and North American use AC power + power cord (250V AC) for European and Korean use AC power + power cord (250V AC) for Chinese use
					A						Modification No.
					B						
					C						
							5				<SD memory card> None Provided (512MB)
								0			<Bound instruction manual/Language> None (Factory-set language: English) Provided/Japanese (Factory-set language: Japanese) Provided/English (Factory-set language: English) Provided/Chinese (Factory-set language: Chinese) (Note1) You can change the language by key operation.
								1			
									Y		
									J		
										E	
											C

### <Detector>

(for transit time)

1	2	3	4	5	6	7	8	9	10	Description	
F	S	C	S	1						<Senser type>(4th digits) ø50 to ø1200mm	
			C							<Guide rail>(5th digits) Provided (Extendable rail type)	
				1						<Mounting belt>(6th digits) *2 None Stainless belt (1.0m×2) Plastic cloth belt (3m×1) SS belt fasten with screws (1.0m×4) Wire ≤ ø1500mm	
					Y					<Acoustic coupler> (7th digit) *1 None Silicone-free grease (HIGH-Z) Silicone grease (G40M)	
					A						
					B						
					C						
								Y		<Water-proof treatment>(9th digit) None Provided (with signal cable 10m) *Submersible in water for 5 days	
									B		<Tag plate> (10th digit) None Provided
									Y		
									A		

- \*1: Normally select silicone grease as acoustic coupler. Silicone grease is tube (100g). Select silicone-free grease for semiconductor manufacturing equipment or the like that is vulnerable to silicone. The silicone-free grease is water-soluble and, therefore, cannot be used in environment exposed to water or on piping subjected to a condensation. Since the grease does not set, a periodic maintenance (cleaning, refilling every about 6 months at normal temperature) is necessary.
- \*2: Please refer to the table 2 to select the mounting belt at 6th digits.

[Table 2] How to select at 6th digits.

Mounting method	≤ø300mm	≤ø600mm	≤ø1200mm
V method	B, A or C	C	D
Z method	C	D	D

## SCOPE OF DELIVERY

### <Flow transmitter : FSC>

Name of unit	Scope of delivery
1 Basic system	1) Conversion unit 2) Power adapter and Power connector conversion cord 3) Power cord 4) Analog input/output cord (1.5m) 5) USB cable (1m) 6) Carrying case 7) Strap 8) Special type signal cable (5m × 2)
2 Option	1) SD memory card (512MB) 2) Bound instruction manual (including a detector)

### <Detector : FSS>

Name of unit	Scope of delivery
1 Detector for propagation time difference (FSS)	1) Sensor unit 2) Signal cable conversion code (included with FSSE) 3) Mounting belt/wire 4) Silicone grease (Article specified)

Note 1) Silicon grease is for filling a gap between a detector and a pipe joint area. It is provided with a detector. Since silicon grease does not become hardened, if you use it in the long term, periodic maintenance is required. (Under the condition of room temperature, semiannual cleaning and refill is recommended.)

Note 2) When you order a detector alone, an instruction manual is not provided. Please request, if necessary (Onerous).



Note: The hand strap and the stand cannot be used simultaneously.

## OPTIONAL ITEMS

Name	Specifications	Arrangement No.
1 Battery	Special type Li-ion battery (7.2V)	ZZP*TKQ508314P1 *Order in two pairs.
2 AC power adapter	Special type power adapter and 100 to 240V +10%/-15% AC, 50/60Hz	ZZP*TKQ505735C4
3 Power cord	Japan, North America: 125V AC 2m Europe, Korea: 250V AC 2m China: 250V AC 2m	ZZP*TK7N6621P1 ZZP*TK7N6608P1 ZZP*TK7N6609P1
4 Silicone grease	Maker: Shin-Etsu Chemical Co., Ltd. Type: · For standard use G40M, 100g · For silicone free 100g · For high temperature KS62M, 100g	ZZP*45231N5 ZZP*TK7M0981P1 ZZP*TK7P1921C1
5 Signal cable	Special type signal cable, 5m × 2 (connector on both - sides)	ZZP*TK7N7795C1
6 Extension signal cable	Special type coaxial cable with BNC connector · 10m × 2 · 50m × 2	ZZP*TK468664C3 ZZP*TK468664C4
7 Analog input/output cable	6-core cable, 1.5m, with connector	ZZP*TKQ405191C1
8 Mounting belt / wire	· Plastic cloth belt · Stainless wire Nominal diameter ø200 to ø500mm ø200 to ø1000mm ø200 to ø2000mm ø200 to ø3000mm ø200 to ø6000mm · Stainless steel belt	ZZP*TK7G7979C1 ZZP*TK7G7980C1 ZZP*TK7G7980C2 ZZP*TK7G7980C3 ZZP*TK7G7980C4 ZZP*TK7G7980C5 ZZP*TK7P1943C1
9 Guide rail for high-temperature sensor (In mounting by the Z method)	· Mounting bracket material: Aluminum alloy+SUS304 For FSSH	ZZP*TK4J5917C3
10 Guide rail for small type detector (In mounting by the Z method)	· Mounting bracket material: Aluminum alloy+plastic For FSSD3 (L=540mm)	ZZP*TK4J5917C1
11 SD memory card	Maker: Hagiwara Solutions co., Ltd Type: NSD6-512MS(P11SEI) Capacity: 512MB	ZZP*G39409151Z
12 USB cable	Maker: Sunwa Supply Inc. Type: KU-AMB510 Specifications: Mini USB cable (1.0m)	ZZP*TK7N6622P1
13 Signal cable conversion cord	M4 clamp terminal / BNC jack, L=150mm	ZZP*TK4K6304C1
14 Hand strap	To be attached on the side of transmitter. Strap length: 200 mm	ZZP*TKQ505739C1
15 Stand	Holds the transmitter at 45 degree angle	ZZP*TKQ405196P1

## Diagram

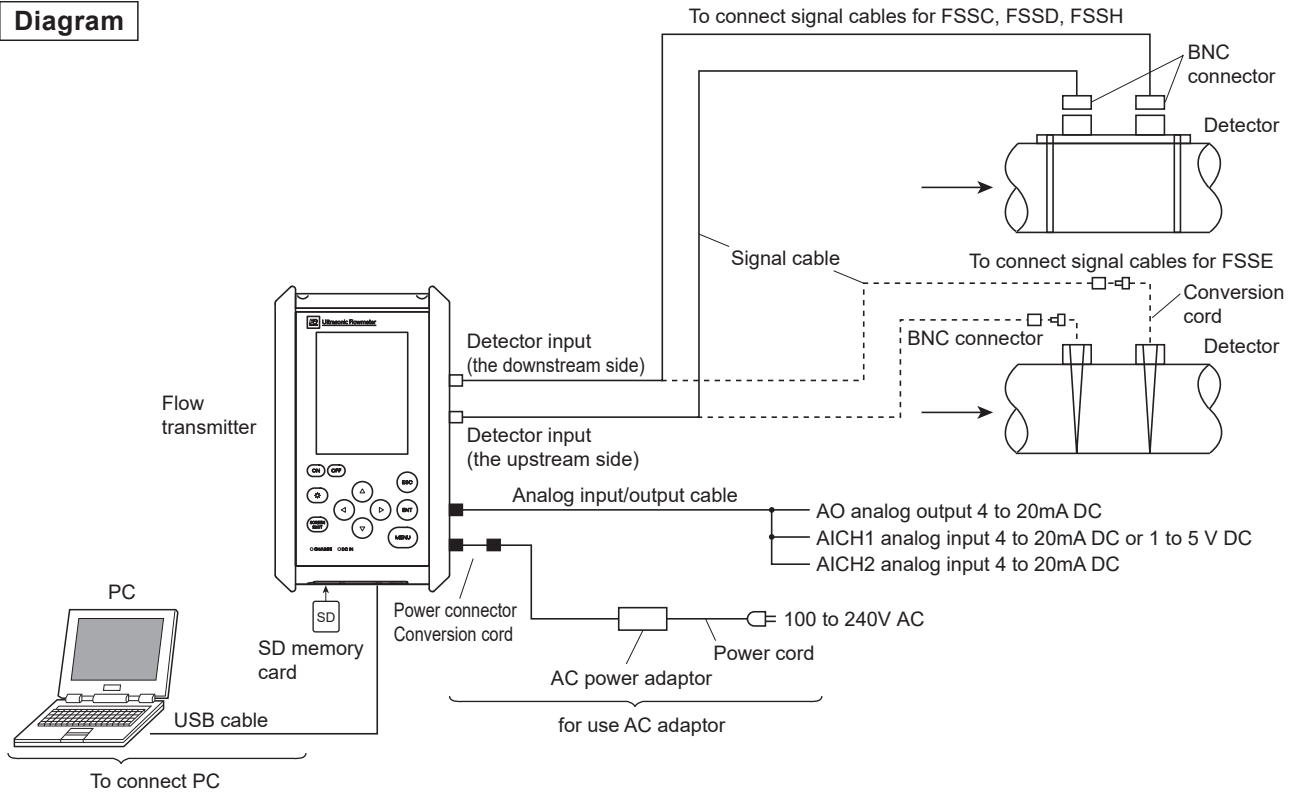

## Pipe requirements

(D: Nominal diameter of pipe)

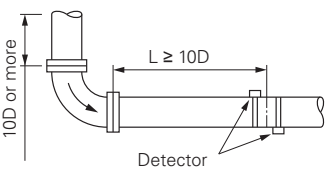
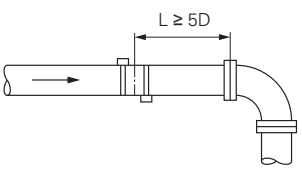
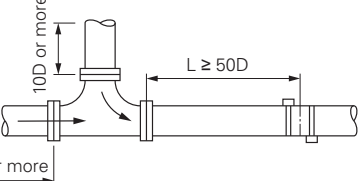
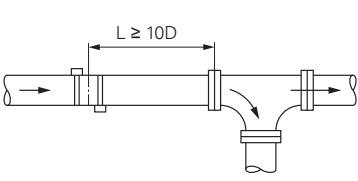
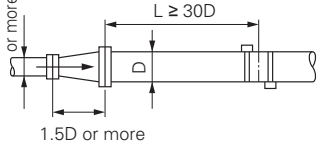
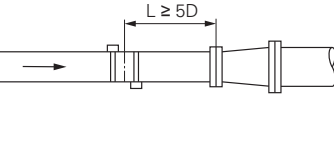
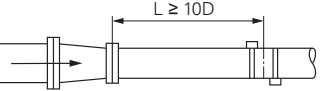
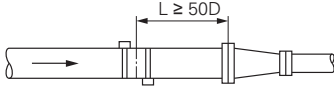
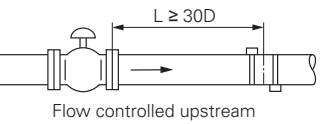
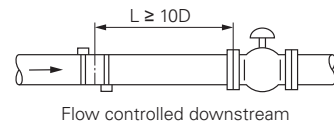
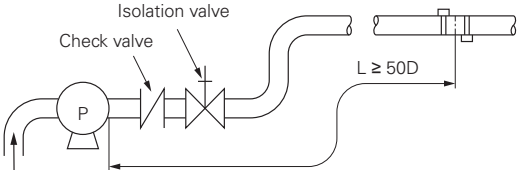
Type	Length of upstream straight pipe	Length of downstream straight pipe
90° bend		
T-shape		
Diffuser		
Tapered		
Valve		
Pump		

Note) Source: Japan Electric Measuring Instruments Manufacturers' Association (JEMIS-032)

# OUTLINE DIAGRAM (Unit:mm)

## Flow transmitter

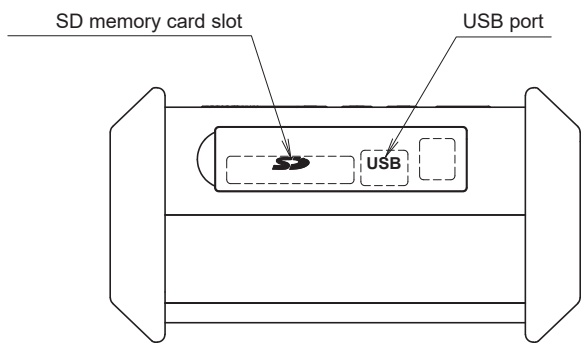
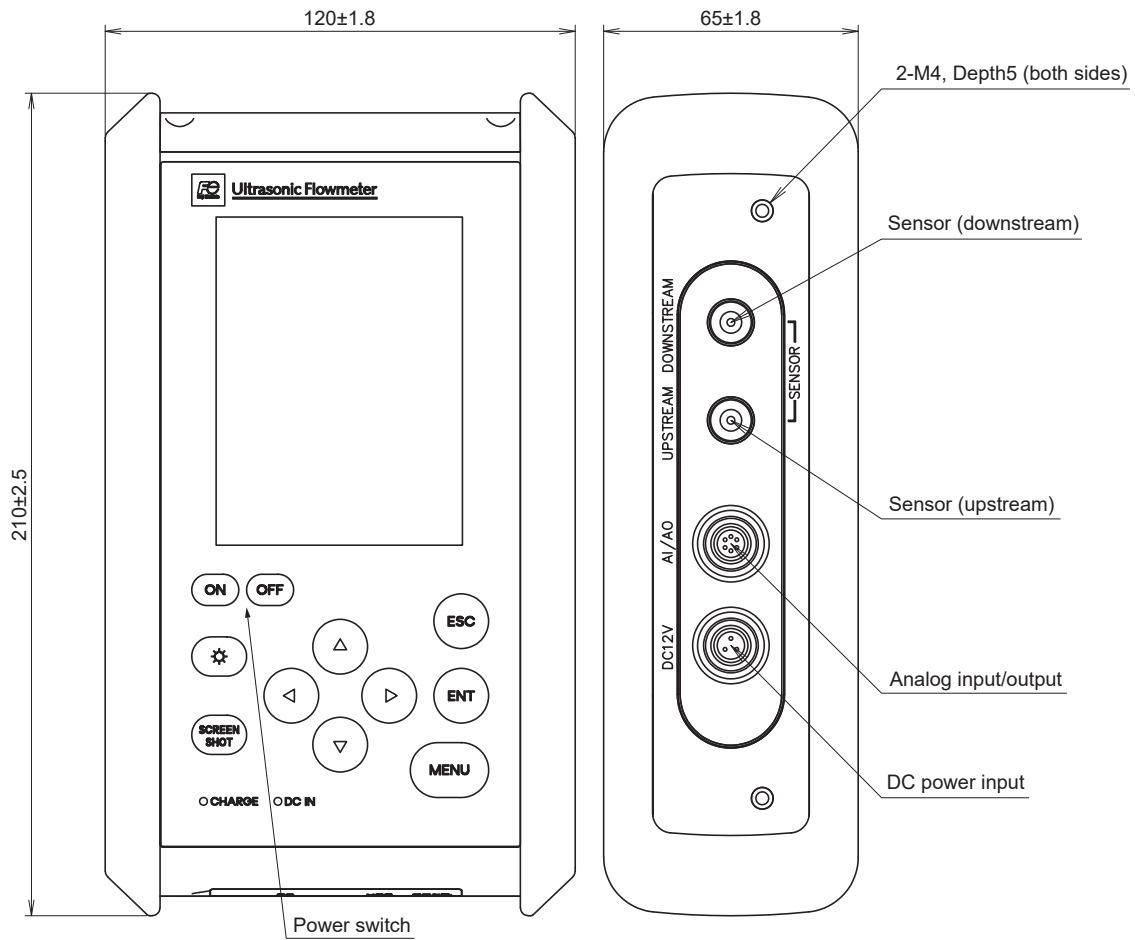

Weight : Approx. 1.0kg

# OUTLINE DIAGRAM (Unit:mm)

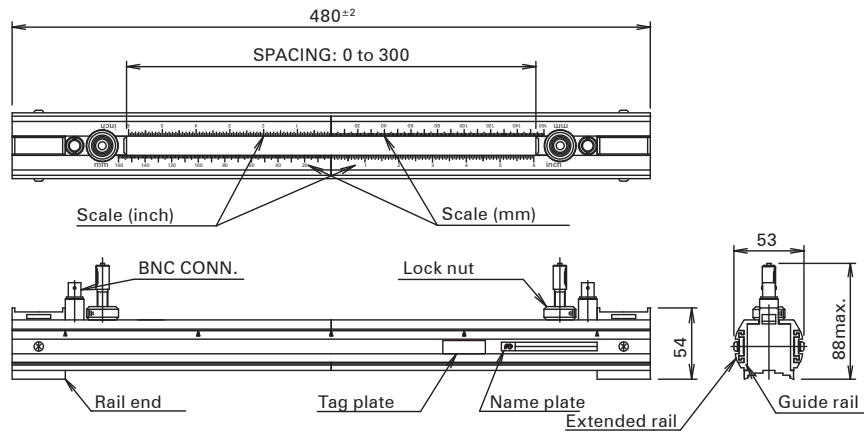

<Shipment style (V method)>

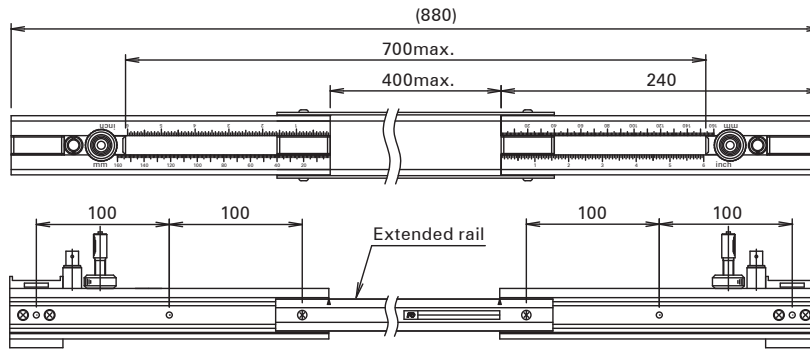

<Extended style (Longest, V method)>

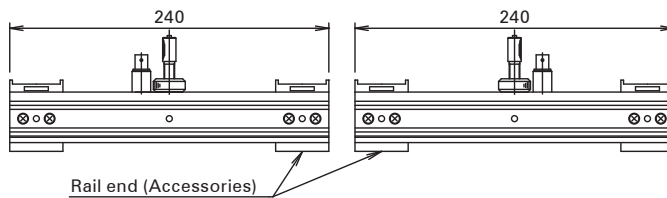

<Separate style (Z method)>

Detector : Type FSSC

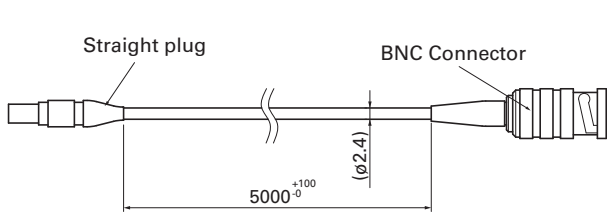

Signal cable

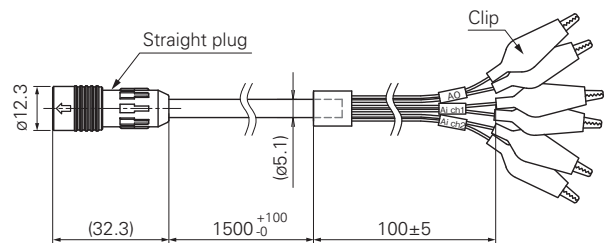

Code color	Clip color	Mark
Black (BK)	Red (R) (+)	AO
White (W)	Black (BK) (-)	
Red (R)	Red (R) (+)	AI ch1
Green (G)	Black (BK) (-)	AI ch2
Yellow (Y)	Red (R) (+)	
Brown (BN)	Black (BK) (-)	

Analog input/output cable

**Detector for special application 1) detector for small diameter type**

Pipe size:  $\phi 13$  to 100mm (300mm max.)  
 Fluid temperature:  $-40$  to  $100^{\circ}\text{C}$   
 Type: FSSD□□□1-Y□

**Specification**

- Sensor frequency: 2MHz
- Mounting method: V method, Z method (FSSD3)
- Fluid temperature:  $-40$  to  $100^{\circ}\text{C}$
- Applicable pipe material: PVC, SS, carbon steel pipe, copper pipe, aluminum pipe, etc.  
 [In case lining is removed from the pipe, Measurement can not be conducted]
- Rated accuracy of combination with the flow transmitter (Applicable piping: plastic, metal pipe)

Internal diameter (mm)	Velocity	Accuracy
$\phi 13$ to $\phi 50$	2 to 32m/s	$\pm 1.5\%$ to $\pm 2.5\%$ of rate
	0 to 2m/s	$\pm 0.03$ to $\pm 0.05\text{m/s}$
$\phi 50$ to $\phi 100$ ( $\phi 300$ )	2 to 32m/s	$\pm 1.0\%$ of rate
	0 to 2m/s	$\pm 0.02\text{m/s}$

- Mounting belt: according to specified code of symbol.
- Material: PBT, guide rail: aluminum alloy + plastic
- Type of enclosure: IP52
- Acoustic coupler: according to specified code of symbol.
- Mass: 0.6kg, 0.8kg

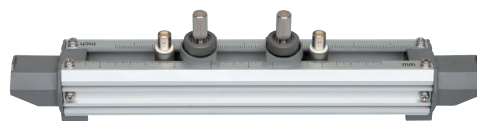

**CODE SYMBOL**

<Detector>

1	2	3	4	5	6	7	8	9	10	Description
F	S	S	D					1	Y	
										<Sensor type>(4th digits) $\phi 13$ to $\phi 100\text{mm}$
										<Guide rail>(5th digits) Provided (L=320mm) $\leq \phi 100\text{mm}$ long rail (L=540mm) $\leq \phi 300\text{mm}$
										<Mounting belt>(6th digits) None Stainless belt (1.5mX2) Plastic cloth belt (3mX1) SS belt fasten with screws (1.0mX4)
										<Acoustic coupler> (7th digit) None Silicon rubber (KE348) Silicone-free grease (HIGH-Z) Silicone grease (G40M)
										<Water-proof treatment>(9th digit) None
										<Tag plate> (10th digit) None Provided

**OPTIONAL ACCESSORIES**

Name	Drawing No.
Silicon grease (GM40M)	ZZP*45231N5
Silicon-free grease (HIGH-Z)	ZZP*TK7M0981P1

**Scope of delivery**

- Detector, acoustic coupler and set of the mounting belt according to specified code of symbol

**OUTLINE DIAGRAM (unit: mm)**

<Detector>

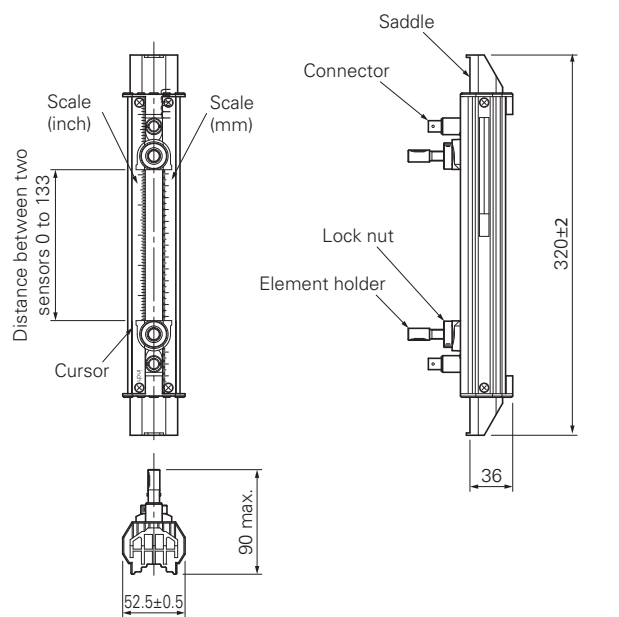

Weight : Approx. 0.6kg

**Small diameter sensor: FSSD1**

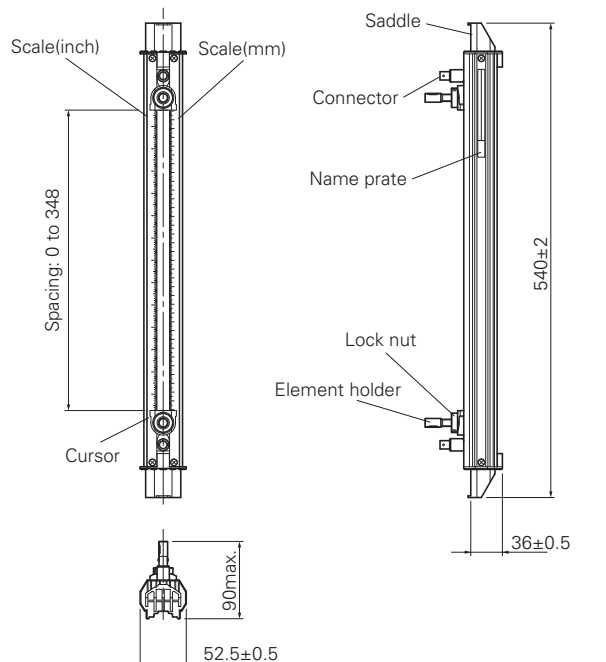

Weight : Approx. 0.8kg

**Detector FSSD3**

## Detector for special application 2) detector for high temperature

Pipe size:  $\phi 50$  to 400mm  
 Fluid temperature:  $-40$  to  $200^{\circ}\text{C}$   
 Type: FSSH1□□1-Y□

### Specification

- Sensor frequency: 2MHz
- Mounting method: V method ( $\phi 50$  to 250mm) or Z method ( $\phi 150$  to 400mm)
- Fluid temperature:  $-40$  to  $200^{\circ}\text{C}$
- Applicable pipe material: PVC, SS, carbon steel pipe, copper pipe, aluminum pipe, etc.  
 [In case lining is removed from the pipe, Measurement can not be conducted]
- Rated accuracy of combination with the flow transmitter (Applicable piping: plastic, metal pipe)

Internal diameter (mm)	Velocity	Accuracy
$\phi 50$ to $\phi 300$	2 to 32m/s	$\pm 1.0\%$ of rate
	0 to 2m/s	$\pm 0.02\text{m/s}$
$\phi 300$ to $\phi 400$	0.75 to 32m/s	$\pm 1.0\%$ of rate
	0 to 0.75m/s	$\pm 0.0075\text{m/s}$

- Mounting belt: according to specified code of symbol.
- Material: sensor housing: SUS304  
 guide rail: SUS304 + aluminum alloy
- Type of enclosure: IP52
- Acoustic coupler: according to specified code of symbol.
- Mass: 1.6kg

### OUTLINE DIAGRAM (unit: mm)

<Detector>

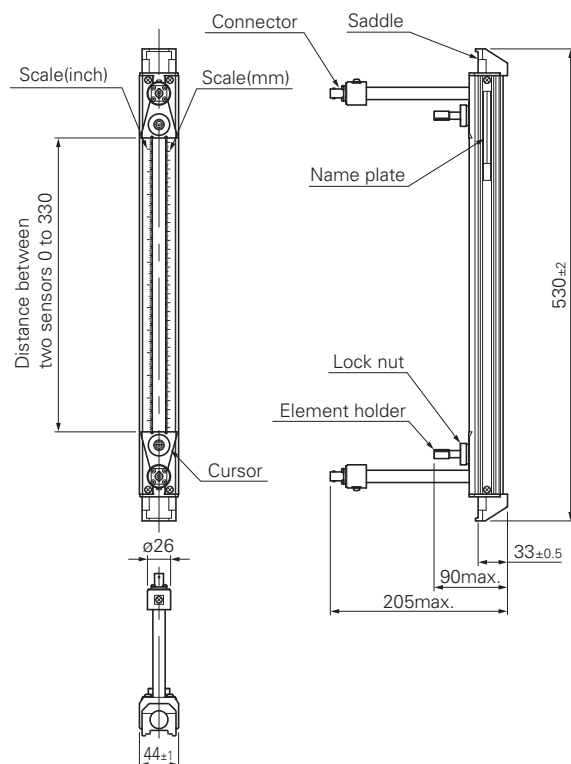

High-temperature sensor: FSSH

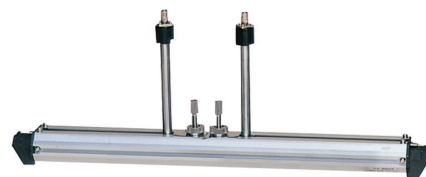

### CODE SYMBOL

<Detector>

1	2	3	4	5	6	7	8	9	10	Description
F	S	H	1					1	Y	<Sensor type>(4th digits) $\phi 50$ to $\phi 400\text{mm}$ ( $-40$ to $200^{\circ}\text{C}$ )
			H							<Guide rail>(5th digits) Provided
			1							<Mounting belt>(6th digits) None Stainless belt (1.5m $\times$ 2) SS belt fasten with screws (1.0m $\times$ 4)
				Y						<Acoustic coupler> (7th digit) None High-temperature grease (KS62M)
				A						<Water-proof treatment>(9th digit) None
					Y					<Tag plate> (10th digit) None
									A	Provided

### OPTIONAL ACCESSORIES

Name	Drawing No.
Guide rail for high-temperature sensor (Z method)	ZZP*TK4J5917C3
High-temperature grease(KS62M)	ZZP*TK7G7983C1

### Scope of delivery

- Detector, acoustic coupler and set of the mounting belt according to specified code of symbol

**Detector for special application 3) detector for large diameter type**

Pipe size:  $\phi 200$  to 6000mm  
 Fluid temperature:  $-40$  to  $80^{\circ}\text{C}$   
 Type: FSSE1□□1-□□

**Specification**

- Sensor frequency: 0.5MHz
- Mounting method: V or Z method
- Fluid temperature:  $-40$  to  $80^{\circ}\text{C}$
- Applicable pipe material: PVC, SS, carbon steel pipe, copper pipe, aluminum pipe, etc.
  - \* In case lining is removed from the pipe, Measurement can not be conducted
- Also applicable to water-proof type according to specified code of symbol (submerged resistant structure for 5days including 10m cable)
- Rated accuracy of combination with the flow transmitter (Applicable piping: plastic, metal pipe)

Internal diameter (mm)	Velocity	Accuracy
$\phi 200$ to $\phi 300$	2 to 32m/s	$\pm 1.5\%$ of rate
	0 to 2m/s	$\pm 0.03\text{m/s}$
$\phi 300$ to $\phi 1200$	0.75 to 32m/s	$\pm 1.5\%$ of rate
	0 to 0.75m/s	$\pm 0.0113\text{m/s}$
$\phi 1000$ to $\phi 6000$	1 to 32m/s	$\pm 1.0\%$ of rate
	0 to 1m/s	$\pm 0.02\text{m/s}$

- Mounting belt: according to specified code of symbol.
- Material: Sensor housing PBT, Sensor cover SUS304
- Type of enclosure: IP67  
(silicon rubber is filled up on the terminal block when connecting work)
- Acoustic coupler: according to specified code of symbol.
- Mass: 1.2kg

**OUTLINE DIAGRAM (unit: mm)**

<Detector>

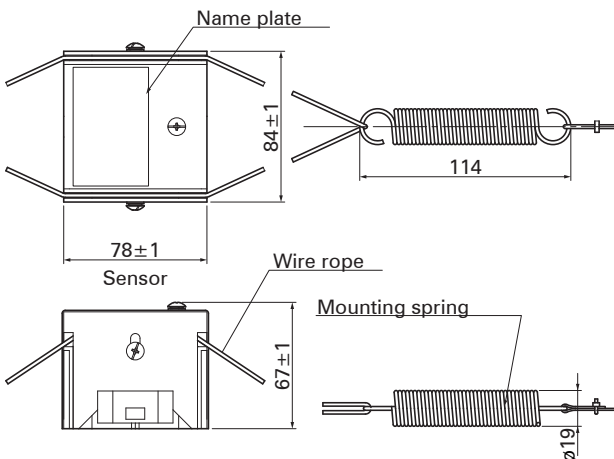

Large sensor: FSSE



**CODE SYMBOL**

<Detector>

1	2	3	4	5	6	7	8	9	10	Description
F	S	S	E	1						<Sensor type>(4th digits) $\phi 200$ to $\phi 6000\text{mm}$
					1					<Guide rail>(5th digits) Provided
						Y				<Mounting belt>(6th digits) None
						D				Wire $\leq \phi 1500\text{mm}$
						E				Wire $\leq \phi 6000\text{mm}$
							Y			<Acoustic coupler> (7th digit) None
							A			Silicon rubber (KE348)
							B			Silicone-free grease (HIGH-Z)
							C			Silicone grease (G40M)
								Y		<Water-proof treatment>(9th digit) None
								B		Provided (with signal cable 10m)
									Y	<Tag plate> (10th digit) None
									A	Provided

**OPTIONAL ACCESSORIES**

Name	Drawing No.
Wire rope for mounting the sensor	
• Spring	ZZP*TK745007P1
• Wire rope (up to $\phi 500\text{mm}$ )	ZZP*TK464686C1
• Wire rope (up to $\phi 1000\text{mm}$ )	ZZP*TK464686C2
• Wire rope (up to $\phi 1500\text{mm}$ )	ZZP*TK464686C3
• Wire rope (up to $\phi 3000\text{mm}$ )	ZZP*TK464686C6
• Wire rope (up to $\phi 6000\text{mm}$ )	ZZP*TK464686C13
Silicon grease (GM40M)	ZZP*45231N5
Silicon rubber (KE348W)	ZZP*45735N2
Silicon-free grease (HIGH-Z)	ZZP*TK7M0981P1

**Scope of delivery**

- Detector, acoustic coupler and set of the mounting belt according to specified cord of symbol
- Signal cable conversion cord

<Signal cable conversion cord>

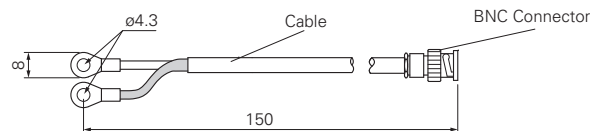

## CHECKED ITEMS BEFORE PURCHASE

Following conditions may cause failure of the measurement or to reduce the accuracy.

Please consult and ask Fuji Electric for checking with actual equipment previously if it is hard to judge the applicability.

### 1) Fluid

- If fluid contains a large amount of bubbles (approx. 12vol% or more at 1m/s flow rate)
- If fluid has bad turbidity 10000(mg/L) or more,
- If fluid contains slurry or solid materials (about 5wt%)
- If flow rate is low Reynolds No.10000 or less, (reference: flow rate 5m<sup>3</sup>/h with ø100mm)
- If it is circulating oil, liquid medicine of low concentration, waste liquid and hot spring,

### 2) Pipe

- If inside pipe is rusty carbon steel pipe,
- If inside pipe having adhering substances and sediment
- If outer surface of cast-iron pipe is rough,
- If pipe wall is tick such as ruinous pipe, (PP material 15mm or more, PVDF material 9mm or more)
- If it is SGPW pipe,
- If lining pipe is removed from pipe, (Teflon, PVC, Glass, etc)
- If it is rubber pipe,

### 3) Pipe straight run

For accurate measurement, a certain length of pipe straight run is required both upstream and downstream of the measurement point. Be sure to satisfy the requirements described on Page 8.

## CAUTION ON USE

- 1) Do not damage the sensor or signal mounted on the pipe.
- 2) Make sure to fill the fluid inside the pipe to measure .
- 3) When you use horizontal pipe, it is recommended to install the sensor horizontally.
- 4) When you use the grease as acoustic coupler to install the sensor for outdoor use, it is recommended to install the waterproof cover to prevent from the degradation.

Information in this catalog is subject to change without notice.  
Read the instruction manuals thoroughly before using the products.

** Fuji Electric Co., Ltd.**

Gate City Ohsaki, East Tower, 11-2, Osaki 1-chome, Shinagawa-ku, Tokyo 141-0032, Japan  
Phone: +81-3-5435-7111  
[www.fujielectric.com](http://www.fujielectric.com)  
[www.fujielectric.com/products/sensors\\_measurements/instruments/index.html](http://www.fujielectric.com/products/sensors_measurements/instruments/index.html)

