

Indicador digital con entrada para:
 ALTA TENSIÓN (10 a 600V AC)
 CAPTADORES: MAGNÉTICO, NAMUR, NPN y PNP
 TTL/24V ENCODER
 CONTACTO LIBRE



Indicateur digitale pour signaux d'entrée:
 HAUTE TENSION (10 à 600V AC)
 CAPTEURS: MAGNÉTIQUE, NAMUR, NPN et PNP
 TTL/24V CODEUR
 CONTACT SEC

Digital indicator for input signal:
 HIGH VOLTAGE (10 to 600V AC)
 SENSORS: MAGNETIC, NAMUR, NPN and PNP
 TTL/24V ENCODER
 CONTACT SWITCH

Digitalanzeige für Eingangssignal:
 HOCHSPANNUNG (10 bis 600V AC)
 SENSOREN: MAGNETISCHE, NAMUR, NPN und PNP
 TTL/24V DREHGEBER
 KONTAKTSCHALTER

GUIA RÁPIDA DE INSTALACIÓN GUIDE RAPIDE D'INSTALLATION QUICK INSTALLATION GUIDE SCHNELL-INSTALLIERUNGSANLEITUNG



	CONTADOR. COMPTEUR. COUNTER. ZÄHLER.	TACÓMETRO. TACHYMÈTRE. TACHOMETER. DREHZAHLMESSE.
Precisión Précision Accuracy Genauigkeit	-	±(0.01% rdg + 1d)
Frecuencia máx. Fréquence max. Max. frequency Max. Frequenz	7.5kHz	25kHz
Frecuencia mín. Fréquence min. Min. frequency Min. Frequenz	-	0.01Hz
ENTRADA ALTA TENSIÓN. ENTRÉE HAUTE TENSION. HIGH VOLTAGE INPUT. HOCHSPANNUNG EINGANG.		
Rango Plage Range Bereich	10V AC - 600V AC	
CAPTADOR MAGNÉTICO. CAPTEUR MAGNÉTIQUE. MAGNETIC SENSOR. MAGNETISCHE SENSOR.		
Sensibilidad Sensibilité Sensitivity Empfindlichkeit	F ≥ 1kHz V _m min. ≥ 100mV	
CAPTADOR NAMUR. CAPTEUR NAMUR. NAMUR SENSOR. NAMUR SENSOR		
R _C I _{ON} I _{OFF}	1KΩ < 1mA DC > 3mA DC	
Excitación Excitation Excitation Speisung	8V @ 60mA	

CONTADOR. COMPTEUR. COUNTER. ZÄHLER. TACÓMETRO. TACHYMÈTRE. TACHOMETER. DREHZAHLMESSE.	
CAPTADOR NPN/PNP. CAPTEUR NPN/PNP. NPN/PNP SENSOR. NPN/PNP SENSOR	
R _C	1KΩ
Niveles lógicos Niveaux logiques Logic levels Logische Zustände	"0" < 2.4V DC "1" > 2.6V DC
TTL/24V ENCODER. TTL/24V CODEUR. TTL/24V ENCODER. TTL/24V DREHGEBER	
Niveles lógicos Niveaux logiques Logic levels Logische Zustände	"0" < 2.4V DC "1" > 2.6V DC
Excitación Excitation Excitation Speisung	24V±3V @ 30mA
CONTACTO LIBRE. CONTACT SEC. CONTACT SWITCH. KONTAKTSCHALTER	
V _C R _C	5V 3.9kΩ
Filtro Filtre Filter Filter	F _C = 20Hz

RANGO DE DISPLAY. PLAGE D'AFFICHAGE. DISPLAY RANGE. ANZEIGEBEREICH.	
Contador / Totalizador Compteur / Totalisateur Counter / Totalizer Zähler / Summenzähler	0 - 9999 / 0 - 999999
Tacómetro Tachymètre Tachometer Drehzahlmesser	0 - 9999

Conformidad CE. Conformité CE. CE Conformity. CE-Konformität.

Directivas Directives Directives Richtlinien	EMC 2004/108/EC	LVD 2006/95/EC
Normas Normes Standards Normen	EN 61326-1	EN 61010-1



Según la Directiva 2002/96/CE, no puede deshacerse de este aparato como un residuo urbano normal. Puede devolverlo, sin coste alguno, al lugar donde fue adquirido para que de esta forma se proceda a su tratamiento y reciclado controlados.
 Selon la Directive 2002/96/CE, l'utilisateur ne peut se défaire de cet appareil comme d'un residu urbain courant. Vous pouvez le restituer, sans aucun coût, au lieu où il a été acquis afin qu'il soit procédé à son traitement et recyclage contrôlés.
 According to 2002/96/CE Directive, You cannot dispose of it at the end of its lifetime as unsorted municipal waste. You can give it back, without any cost, to the place where it was acquired to proceed to its controlled treatment and recycling.
 Gemäß der Richtlinie 2002/96/EG darf dieses Elektronikgerät nicht über den herkömmlichen Haushaltsmüllkreislauf entsorgt werden. Sie kann das Gerät kostenlos an die Stelle von der es erworben wurde, für die kontrollierte Bearbeitung und Wiederverwertung zurückgeben.

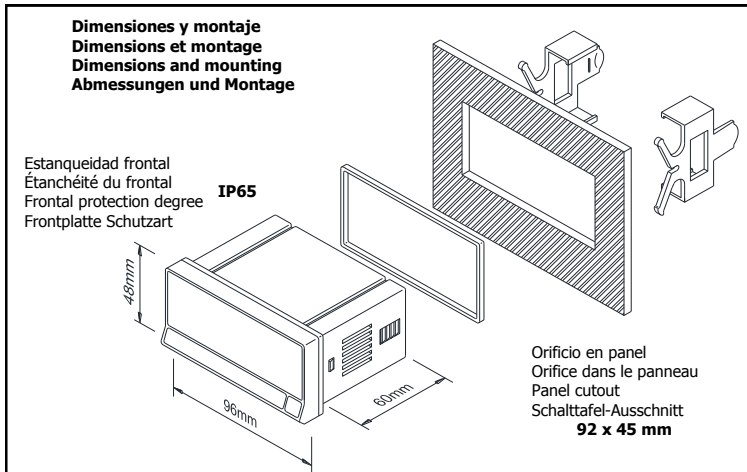
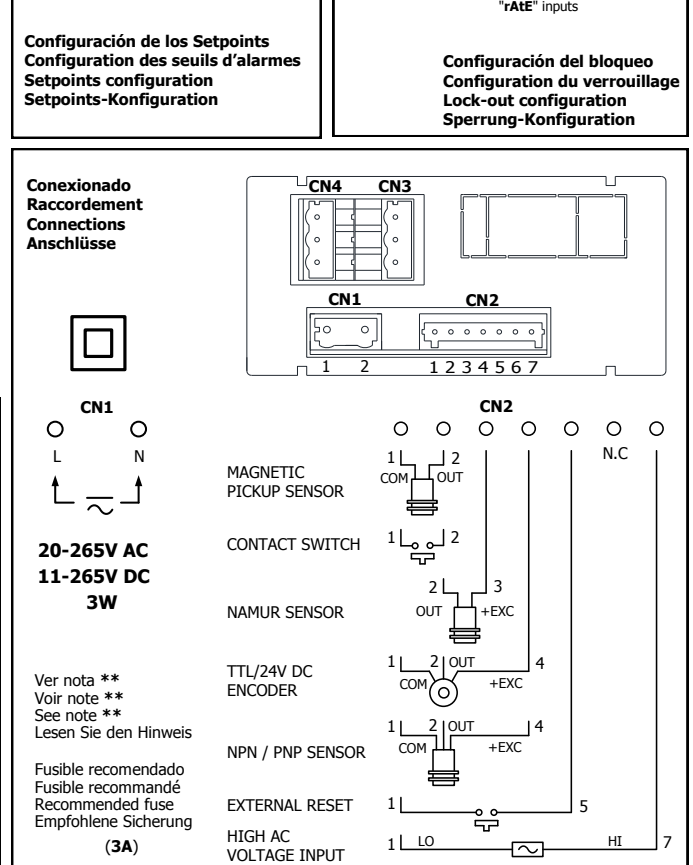
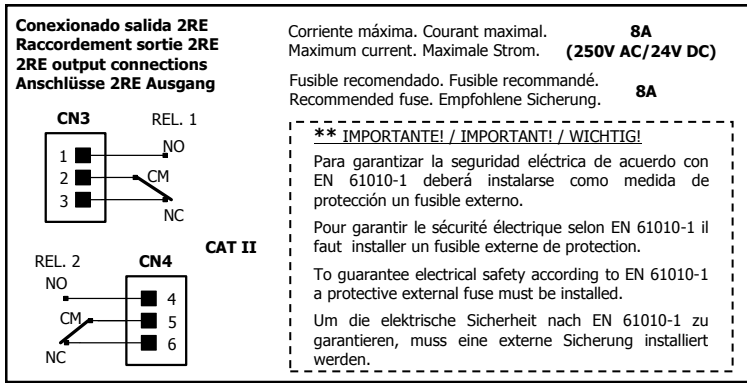
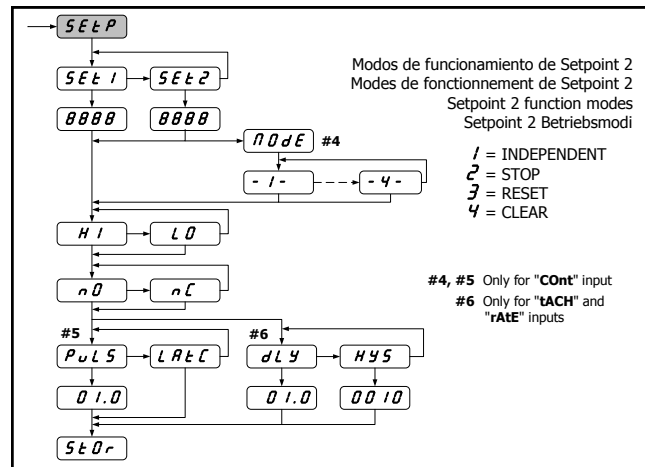
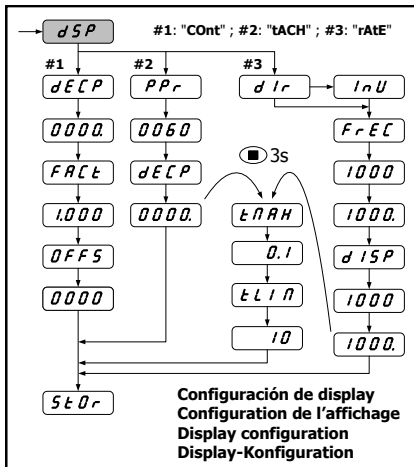
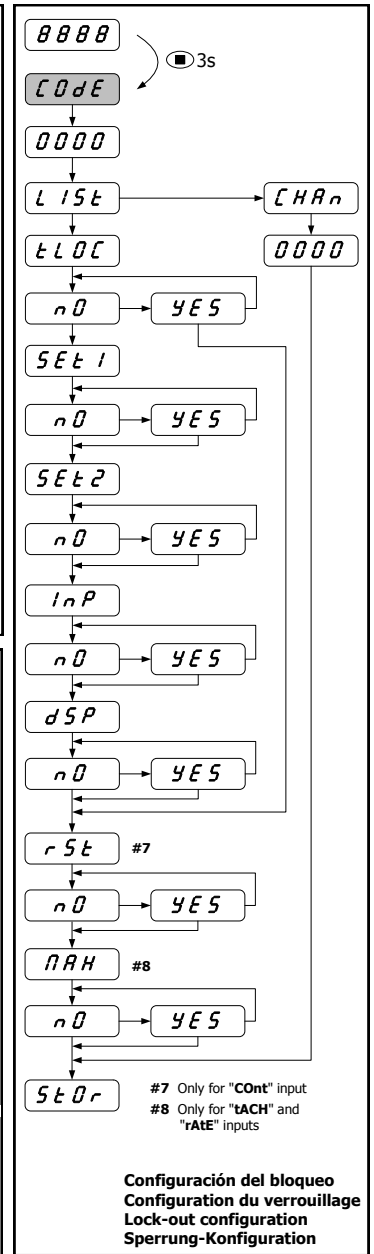
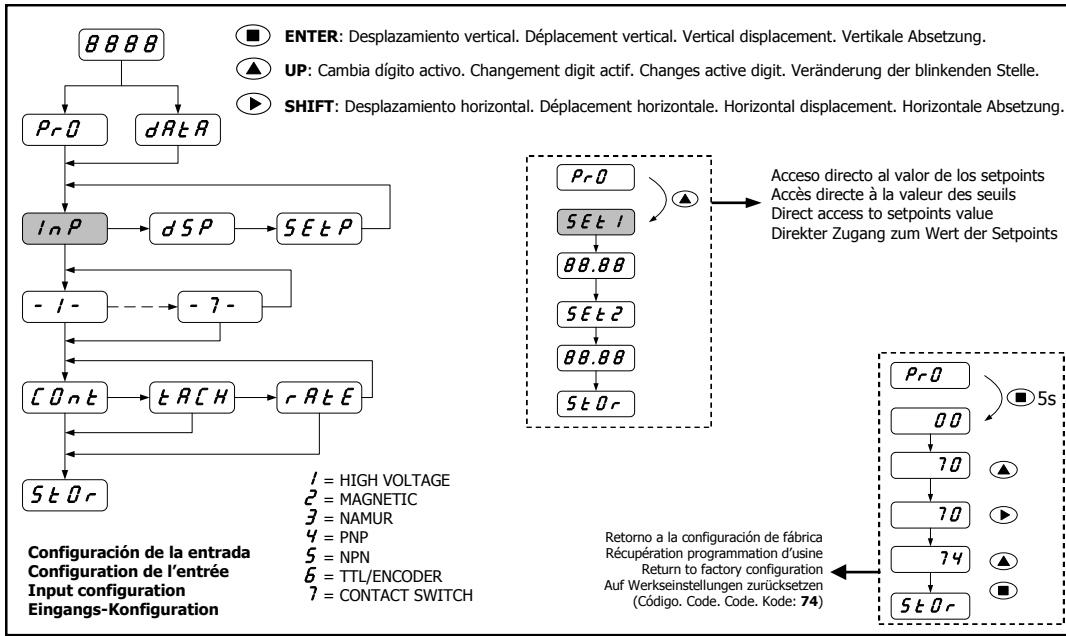

FUJI ELECTRIC FRANCE S.A.S.
46, rue Georges Besse - ZI du Brézet 63039 Clermont-Ferrand Cedex 2 - France
Tél. France 04 73 98 26 98 - Fax. 04 73 98 26 99
Tel. international +33 4 73 98 26 98- Fax. +33 4 73 98 26 99
Email : sales.dpt@fujielectric.fr Web : www.fujielectric.fr

Fuji Electric cannot be held responsible for any errors in our catalogues, brochures or other printed media. Fuji Electric reserves the right to modify its products without notice. This also applies to the products ordered, if the modifications do not alter the specifications substantially. The registered marks and names which appear in this document are the property of their respective depositors. All rights reserved.