

UNIVERSAL TRANSMITTER
(field- and PC-configurable)

MODEL **M3LU**

BEFORE USE

Thank you for choosing M-System. Before use, check the package you received as below.

If you have any problems or questions with the product, please contact M-System's Sales Office or representatives.

■ **PACKAGE INCLUDES:**

- Signal conditioner (1)
- Terminal block with CJC sensor (1)
- I/O range and tag name label sheet (1)

■ **MODEL NO.**

Check that the model No. described on the specification label is exactly what you ordered.

■ **INSTRUCTION MANUAL**

This manual describes the necessary points of caution when you use this product, including installation, connection and basic maintenance procedures.

POINTS OF CAUTION

■ **CONFORMITY WITH CE DIRECTIVES**

- This equipment is suitable for use in a Pollution Degree 2 environment and in Installation Category II, with the maximum operating voltage of 300V. Operational insulation is maintained between the input and output. The input signal must be 10V or less for CE conformance.
- Altitude up to 2000 meters
- The equipment must be mounted inside a panel.
- Insert a noise filter for the power source connected to the unit. Densai-Lambda Noise Filter Model MZS-1220-33 or equivalent is recommended.

The actual installation environments such as panel configurations, connected devices, connected wires, may affect the protection level of this unit when it is integrated in a panel system. The user may have to review the CE requirements in regard to the whole system and employ additional protective measures to ensure the CE conformity.

■ **POWER INPUT RATING & OPERATIONAL RANGE**

- Check the power rating for the unit on the specification label.
Rating 100 – 240V AC: 85 – 264V, 47 – 66 Hz, approx. 4 – 6VA

Rating 10 – 32V DC: 9 – 36V, approx. 2W

- Power fuse: A power fuse of the rating as shown below is incorporated for safety. However, DO NOT replace it by the user.

AC Rating: T 0.25A 250V

DC Rating: T 0.5A 250V

■ **SAFETY PRECAUTION**

- Before you remove the unit or mount it, turn off the power supply and input signal for safety.

■ **ENVIRONMENT**

- Indoor use
- When heavy dust or metal particles are present in the air, install the unit inside proper housing with sufficient ventilation.
- Do not install the unit where it is subjected to continuous vibration. Do not subject the unit to physical impact.

- Environmental temperature must be within -25 to +65°C (-13 to +149°F) with relative humidity within 0 to 95% RH in order to ensure adequate life span and operation.

■ **WIRING**

- Do not install cables (power supply, input and output) close to noise sources (relay drive cable, high frequency line, etc.).
- Do not bind the unit's cables together with cables where high noise levels are present. Do not install them in the same duct.

■ **AND**

- The unit is designed to function as soon as power is supplied, however, a warm up for 10 minutes is required for satisfying complete performance described in the data sheet.

COMPONENT IDENTIFICATION

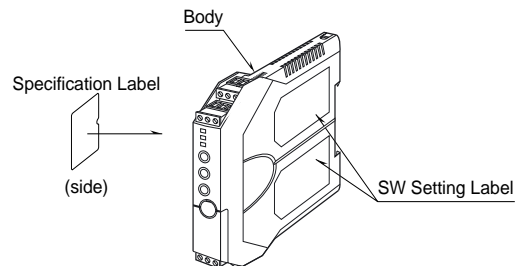

■ **HOW TO OPEN THE COVER WHEN SETTING DIP SW**

Hold at the top and bottom of the unit as shown below and slide the housing cover gently to open until it hits the latching

Caution:

Handle the cover carefully to protect internal components from damage. DO NOT pull beyond where the housing cover is latched. The plastic housing may be damaged.

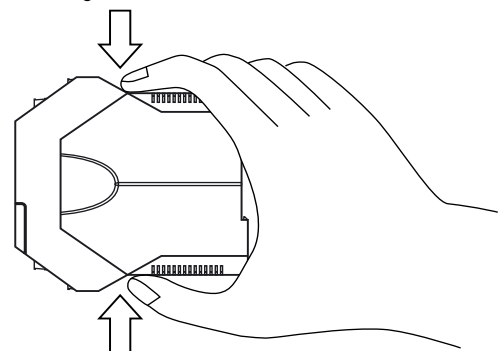

• **Housing Cover Fully Opened**

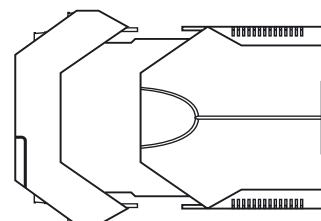

inside the unit.

■ HOW TO SEPARATE THE TERMINAL BLOCKS

When you need to separate the terminal blocks from the transmitter body for wiring, insert a minus driver between the terminal block and the housing body, pull up the driver and pull out the terminal block.

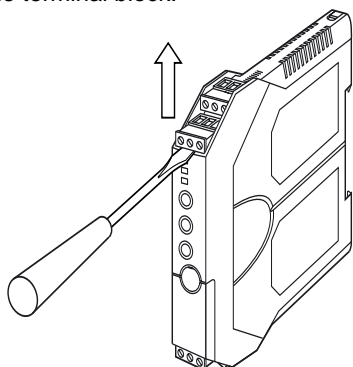

INSTALLATION

■ DIN RAIL MOUNTING

Set the unit so that its DIN rail adaptor is at the bottom. Position the upper hook at the rear side of the unit on the DIN rail and push in the lower. When removing the unit, push down the DIN rail adaptor utilizing a minus screwdriver and pull.

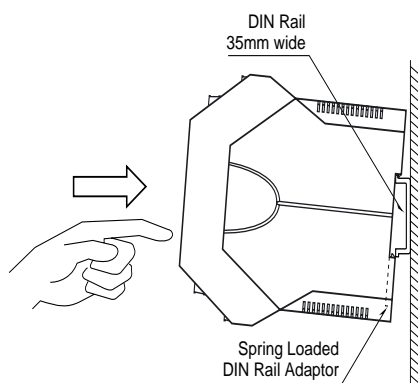

TERMINAL CONNECTIONS

Connect the unit by referring to the diagram below.

EXTERNAL DIMENSIONS mm (inch)

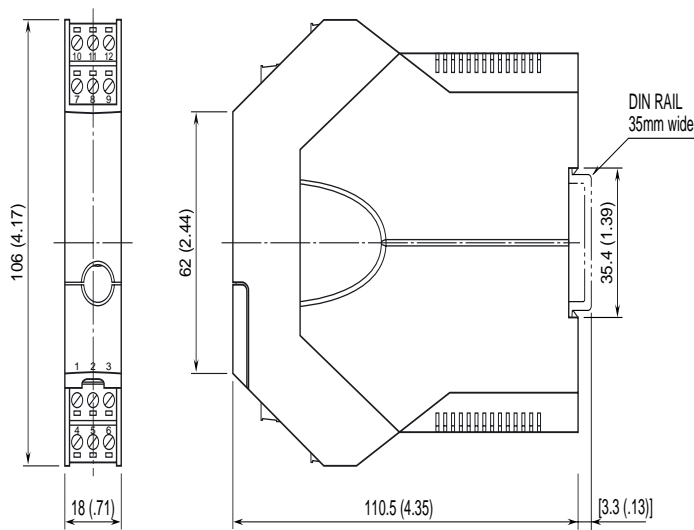

*When mounting, no extra space is needed between units.

CONNECTION DIAGRAM DC POWERED TYPE

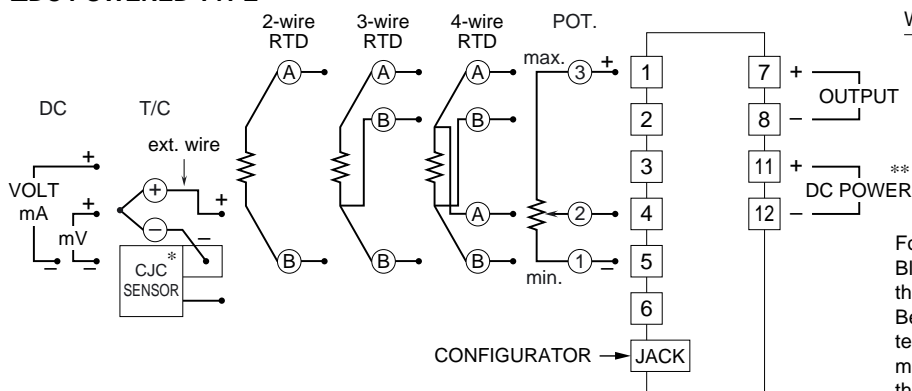

CJC SENSOR TERMINAL BLOCK

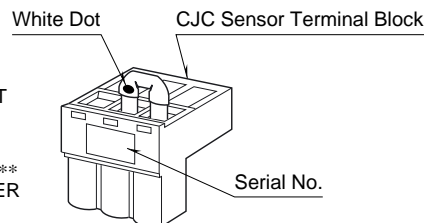

For a thermocouple input, replace the Terminal Block (4 – 5 – 6) with the one connected with the CJC Sensor included in the package. Be careful not to separate the Sensor from the terminal block. If you did, connect the CJC leg marked with a white dot to the terminal 5 and the other leg to the terminal 6. The CJC Sensor is calibrated to a particular unit and not interchangeable with another. Match the Serial No. of the unit and the sensor.

AC POWERED TYPE

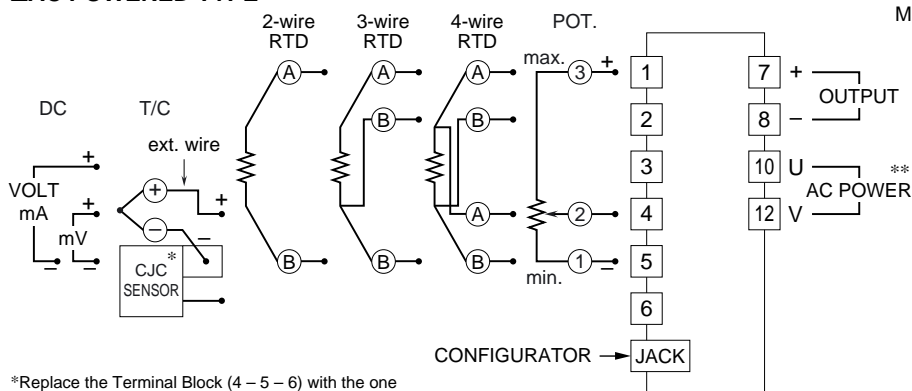

*Replace the Terminal Block (4 – 5 – 6) with the one connected with the CJC Sensor, included in the package. The CJC Sensor is secured to the terminal 6. Loosen only the terminal 4 – 5 and connect the T/C extension wires.

**Be aware that the AC power and DC power connect to different terminals.

EXTERNAL & INTERNAL VIEWS

FRONT VIEW

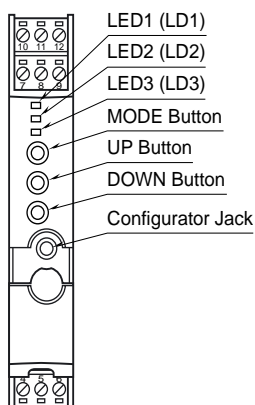

SIDE VIEW

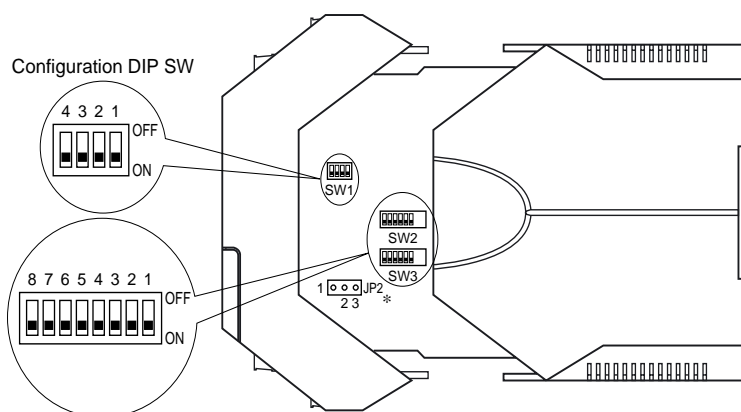

*For Voltage Input (V) range, switch the JP2 jumper to the 2 – 3 position.

Normal Position
(other than DC Voltage [V] range)

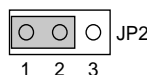

DC Voltage [V] Range Position

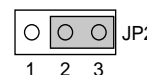

CONFIGURATION MODE & DIP SW SETTINGS

When you program the transmitter module, two configuration modes are available: Field Configuration using DIP SW / control buttons, and PC Software. (The Option B type is for the field configuration only.)

The internal DIP switches are used to configure input and output type. Once the module is configured, precise ranges are set up with the front control buttons using a simulator connected to the input terminals and a multimeter connected to the output terminals as a reference.

The calibrated input and output ranges are stored in the internal memory. The module reads the DIP-switch-calibrated configuration only once after the power supply is turned on. Set the switches with the power supply removed. Selectable I/O type and ranges are listed in Table 11 and 12.

DIP SW CONFIGURATION MODE

Turn the SW3-8 OFF to enable the DIP SW (Field Configuration) mode as shown in Table 1.

See Table 2 through 8 to configure the input and Table 9 for the output.

PC CONFIGURATION MODE

Turn the SW3-8 ON to enable the PC Configuration mode as shown in Table 1. All programmable features can be set up on a PC regardless of other DIP SW setting except for: (1) JP2 to be switched from 1 – 2 to 2 – 3 for DC voltage input (See Notes under Table 2), and (2) the output type must be selected with the DIP SW1-1 through SW1-4 (See Table 10). For detailed information on the PC configuration, refer to the M3CON data sheet.

CONFIGURATION MODE (SW3)

Table 1

MODE	SW3-8	
DIP SW	OFF	Configuration mode can be confirmed with the front LED.
PC	ON	

INPUT TYPE (SW3)

Table 2

INPUT	SW3-7	SW3-6	SW3-5	SW3-4...3-1
DC Current	OFF	OFF	OFF	—
DC mV	OFF	OFF	ON	—
DC Voltage*1	OFF	ON	OFF	—
Thermocouple	OFF	ON	ON	Table 3
RTD	ON	OFF	OFF	Table 4
Potentiometer	ON	OFF	ON	Table 5
Resistance	ON	ON	OFF	—

*1. JP2 position switched from (1 – 2) to (2 – 3) for both DIP SW and PC configuration.

THERMOCOUPLE TYPE (SW3)

Table 3

T/C	SW3-4	SW3-3	SW3-2	SW3-1
(PR)	OFF	OFF	OFF	OFF
K (CA)	OFF	OFF	OFF	ON
E (CRC)	OFF	OFF	ON	OFF
J (IC)	OFF	OFF	ON	ON
T (CC)	OFF	ON	OFF	OFF
B (RH)	OFF	ON	OFF	ON
R	OFF	ON	ON	OFF
S	OFF	ON	ON	ON
C (WRe 5-26)	ON	OFF	OFF	OFF
N	ON	OFF	OFF	ON
U	ON	OFF	ON	OFF
L	ON	OFF	ON	ON
P (Platinel II)	ON	ON	OFF	OFF

■RTD TYPE (SW3)

Table 4

RTD	SW3-4	SW3-3	SW3-2	SW3-1
Pt 100	OFF	OFF	OFF	OFF
Pt 200	OFF	OFF	OFF	ON
Pt 300	OFF	OFF	ON	OFF
Pt 400	OFF	OFF	ON	ON
Pt 500	OFF	ON	OFF	OFF
Pt 1000	OFF	ON	OFF	ON
Pt 50Ω	OFF	ON	ON	OFF
JPt 100	OFF	ON	ON	ON
Ni 100	ON	OFF	OFF	OFF
Ni 120	ON	OFF	OFF	ON
Ni 508.4Ω	ON	OFF	ON	OFF
Ni-Fe 604	ON	OFF	ON	ON
Cu 10 @25°C	ON	ON	OFF	OFF

■POTENTIOMETER (SW3)

Table 5

RESISTANCE	SW3-4	SW3-3	SW3-2	SW3-1
2500 – 4000Ω	OFF	OFF	OFF	OFF
1200 – 2500Ω	OFF	OFF	OFF	ON
600 – 1200Ω	OFF	OFF	ON	OFF
300 – 600Ω	OFF	OFF	ON	ON
150 – 300Ω	OFF	ON	OFF	OFF
100 – 150Ω	OFF	ON	OFF	ON

■RTD/RESISTANCE WIRES (SW2)

Table 6

WIRES	SW2-2	SW2-1
2-wire	OFF	OFF
3-wire	OFF	ON
4-wire	ON	ON

■COLD JUNCTION COMPENSATION (SW2)

Table 7

COLD JUNCTION COMP	SW2-3
Disable	ON
Enable	OFF

■BURNOUT (SW2)

Table 8

BURNOUT	SW2-5	SW2-4
No burnout	OFF	OFF
Upscale	OFF	ON
Downscale	ON	ON

■OUTPUT TYPE (SW2 & 1)

Table 9

OUTPUT	SW2-8	SW2-7	SW1-4	SW1-3	SW1-2	SW1-1
0 – 20mA	OFF	OFF	OFF	ON	OFF	OFF
-2.5 – +2.5V	OFF	ON	ON	OFF	OFF	ON
-10 – +10V	ON	OFF	ON	OFF	ON	OFF

■OUTPUT TYPE / PC CONFIG (SW1)

Table 10

OUTPUT	SW1-4	SW1-3	SW1-2	SW1-1
0 – 20mA	OFF	ON	OFF	OFF
-2.5 – +2.5V	ON	OFF	OFF	ON
-10 – +10V	ON	OFF	ON	OFF

CHECKING

- 1) Terminal wiring: Check that all cables are correctly connected according to the connection diagram.
- 2) DIP SW setting: Check that the switches are set to appropriate positions.
- 3) Power input voltage: Check voltage across the terminal 10 – 12 (AC) or 11 – 12 (DC) with a multimeter.
- 4) Input: Check that the input signal is within 0 – 100% of full-scale.
If the thermocouple, RTD, potentiometer or their extension wires are broken, the output goes over 100% (below 0% with downscale protection) due to burnout function. Confirm the status indicator LED pattern and check leadwires in such a case.
- 5) Output: Check that the load resistance meets the described specifications.

I/O RANGING & FINE ADJUSTMENTS

After the DIP SW setting is complete, set up the precise input and output range using the front control buttons.

The front LEDs' colors and flashing patterns help you to easily identify the transmitter's status and confirm the setup actions in each step of Calibration Modes. Please read the following explanations referring to "Calibration Flow Chart" in Page 5.

■ PREPARATION (e.g. M3LU-R4/A, DC powered type)

- 1) Mount the DIP-SW-configured M3LU on to a DIN rail.
- 2) Connect the M3LU to a simulator and a multimeter and to a DC power source as shown below.
- 3) Turn the power supply on and wait for 10 minutes.

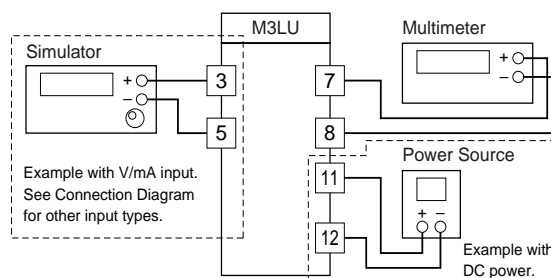

■ INPUT & OUTPUT RANGING

[Example] Setting both input and output to 1 – 5V DC

- 1) Run Mode: Confirm that the LD1 green light is blinking.
- 2) Input Configuration Mode: Press MODE button for longer than 5 seconds until the LD1 red light is ON and the LD2 red light is blinking.
- 3) 0% Input Ranging: Apply the desired minimum input level (e.g. 1V) from the simulator and push DOWN button until the LD1 flashes for approx. 2 sec. and then turns OFF. When you release the button, the LD1 is returned to ON. The flashing LD1 means that the value is stored in the memory. If the LED does not change, the entered level may be inappropriate: too small a span, or out of usable range (same for all steps).
- 4) 100% Input Ranging: Apply the desired maximum input

- level (e.g. 5V) from the simulator and push UP button until the LD1 flashes for approx. 2 sec. and then turns OFF. When you release the button, the LD1 is returned to ON.
- 5) Output Configuration Mode: Push MODE button and confirm that the LD3 red light instead of LD2 is blinking.
 - 6) 0% Output Ranging: Increase or decrease the simulated input until the meter shows the desired minimum output level (e.g. 1V). Push DOWN button until the LD1 flashes for approx. 2 sec. and then turns OFF. When you release the button, the LD1 is returned to ON.
 - 7) 100% Output Ranging: Increase or decrease the simulated input until the meter shows the desired maximum output level (e.g. 5V). Push UP button until the LD1 flashes for approx. 2 sec. and then turns OFF. When you release the button, the LD1 is returned to ON.
 - 8) Run Mode: Programming complete, push MODE button and confirm that only the LD1 green light is blinking.

I/O RANGE LABEL

Blank I/O range labels are included in the product package. Write in the configured ranges and put the label on the side above the specification label as shown below.

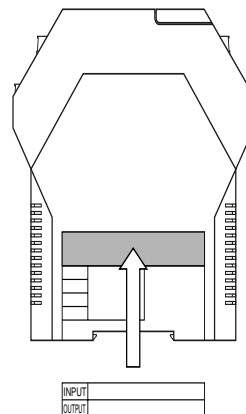

I/O Range Label (included in the product package)

CALIBRATION FLOW CHART

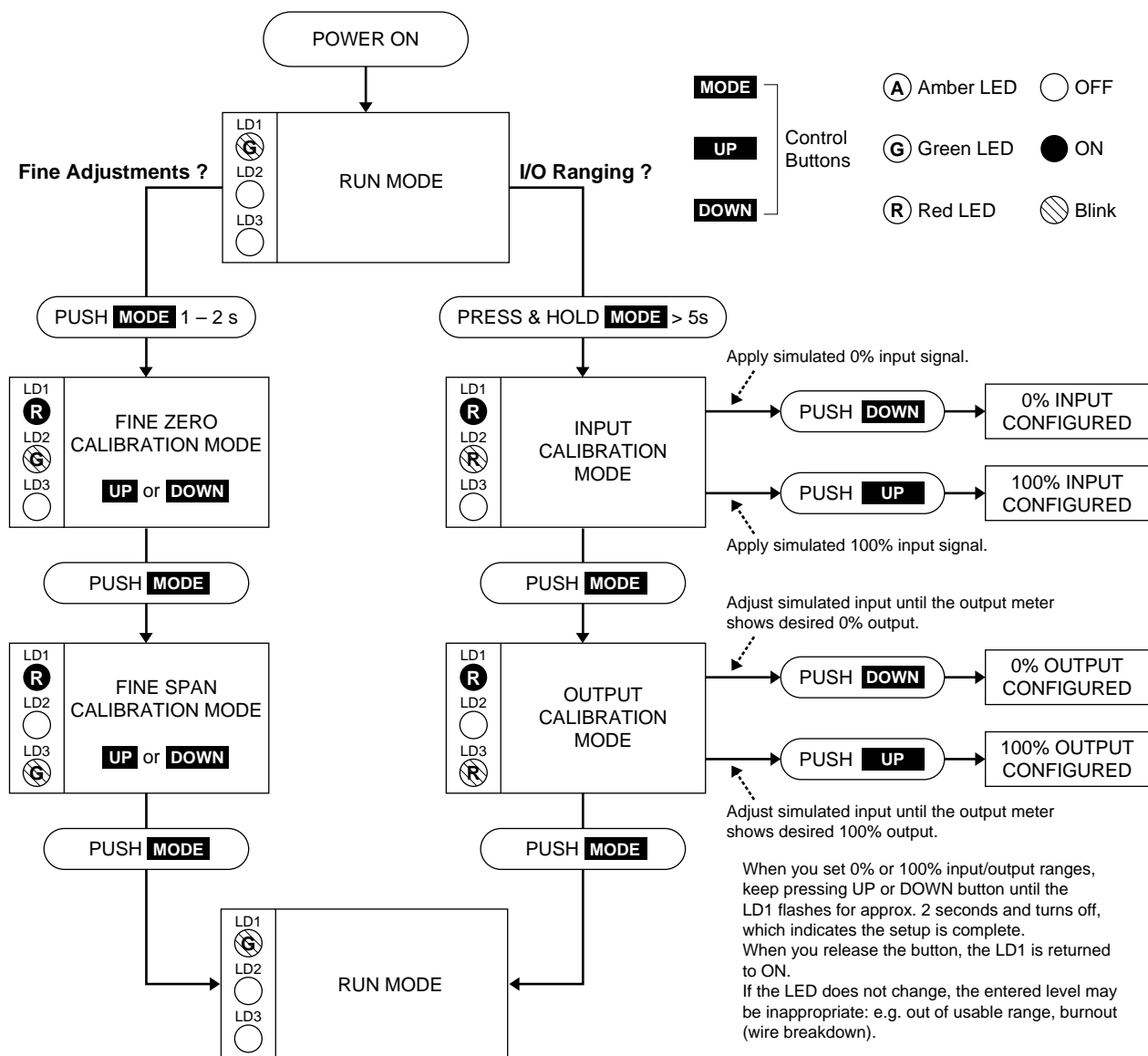

■ INPUT TYPE, RANGE & ACCURACY

Table 11

INPUT TYPE	MIN. SPAN	MAXIMUM RANGE	ACCURACY *1					
DC Current	1mA	0 to 20mA	±0.1%					
DC Millivolt	4mV	-1 to +1V	±10µV at F.S. input ≤50mV ±40µV at F.S. input ≤200mV ±60µV at F.S. input ≤500mV ±80µV at F.S. input >500mV					
DC Voltage	1V	-10 to +10V	±0.1%					
Potentiometer	80Ω	0 to 4000Ω	±0.1%					
Resistance	10Ω	0 to 4000Ω	±0.1Ω					
Thermocouple	MIN. SPAN	MAXIMUM RANGE	CONFORMANCE RANGE	ACCURACY *1	MIN. SPAN	MAXIMUM RANGE	CONFORMANCE RANGE	ACCURACY *1
(PR)	20	0 to 1760	0 to 1760	±1.00	36	32 to 3200	32 to 3200	±1.80
K (CA)	20	-270 to +1370	-150 to +1370	±0.25	36	-454 to +2498	-238 to +2498	±0.45
E (CRC)	20	-270 to +1000	-170 to +1000	±0.20	36	-454 to +1832	-274 to +1832	±0.36
J (IC)	20	-210 to +1200	-180 to +1200	±0.25	36	-346 to +2192	-292 to +2192	±0.45
T (CC)	20	-270 to +400	-170 to +400	±0.25	36	-454 to +752	-274 to +752	±0.45
B (RH)	20	100 to 1820	400 to 1760	±0.75	36	212 to 3308	752 to 3200	±1.35
R	20	-50 to +1760	200 to 1760	±0.50	36	-58 to 3200	392 to 3200	±0.90
S	20	-50 to +1760	0 to 1760	±0.50	36	-58 to +3200	32 to 3200	±0.90
C (WRe 5-26)	20	0 to 2315	0 to 2315	±0.25	36	32 to 4199	32 to 4199	±0.45
N	20	-270 to +1300	-130 to +1300	±0.30	36	-454 to +2372	-202 to +2372	±0.54
U	20	-200 to +600	-200 to +600	±0.20	36	-328 to +1112	-328 to +1112	±0.36
L	20	-200 to +900	-200 to +900	±0.25	36	-328 to +1652	-328 to +1652	±0.45
P (Platinel II)	20	0 to 1395	0 to 1395	±0.25	36	32 to 2543	32 to 2543	±0.45
RTD	MIN. SPAN	MAXIMUM RANGE		ACCURACY *1	MIN. SPAN	MAXIMUM RANGE		ACCURACY *1
Pt 100 (JIS '97/DIN/IEC)	20	-200 to +850		±0.15	36	-328 to +1562		±0.27
Pt 200	20	-200 to +850		±0.15	36	-328 to +1562		±0.27
Pt 300	20	-200 to +850		±0.15	36	-328 to +1562		±0.27
Pt 400	20	-200 to +850		±0.15	36	-328 to +1562		±0.27
Pt 500	20	-200 to +850		±0.15	36	-328 to +1562		±0.27
Pt 1000	20	-200 to +850		±0.15	36	-328 to +1562		±0.27
Pt 50 (JIS '81)	20	-200 to +649		±0.15	36	-328 to +1200		±0.27
JPt 100 (JIS '89)	20	-200 to +510		±0.15	36	-328 to +950		±0.27
Ni 100	20	-80 to +260		±0.15	36	-112 to +500		±0.27
Ni 120	20	-80 to +260		±0.15	36	-112 to +500		±0.27
Ni 508.4	20	-50 to +200		±0.15	36	-58 to +392		±0.27
Ni-Fe 604	20	-200 to +200		±0.15	36	-328 to +392		±0.27
Cu 10 @25°C	20	-50 to +250		±0.50	36	-58 to +482		±0.90

*1. DC Input: Or ±0.1% of span, whichever is greater.

Thermocouple Input: [Accuracy + Cold Junction Compensation Error 0.5°C (0.9°F)] or ±0.1% of span, whichever is greater.

RTD, Resistance Input: Or ±0.1% of span, whichever is greater.

For current output, overall accuracy degrades another 0.1% with spans ≤2mA.

■ OUTPUT TYPE & RANGE

Table 12

OUTPUT TYPE	MINIMUM SPAN	MAXIMUM RANGE	CONFORMANCE RANGE
DC Current	1mA	0 to 20mA	0 to 24mA
DC Voltage, Narrow Spans	250mV	-2.5 to +2.5V	-3 to +3V
DC Voltage, Wide Spans	1V	-10 to +10V	-11.5 to +11.5V

■ ZERO & SPAN ADJUSTMENTS

After the transmitter is installed and operational, fine zero and span tuning can be performed as explained below. Both zero and span are adjustable within $\pm 15\%$.

- 1) Run Mode: Confirm that the LD1 green light is blinking.
- 2) Fine Zero Calibration Mode: Press MODE button for 1 or 2 seconds until the LD1 red light is ON and the LD2 green light is blinking.
- 3) Use UP (increase) and DOWN (decrease) buttons to adjust the output to 0%.
- 4) Fine Span Calibration Mode: Push MODE button and confirm that the LD3 green light instead of LD2 is blinking.
- 5) Use UP (increase) and DOWN (decrease) buttons to adjust the output to 100%.
- 6) Run Mode: Push MODE button and confirm that only the LD1 green light is blinking.







Note 1: Calibration steps can be skipped when not needed by repeating pushing MODE buttons.

Note 2: There is no stated order of setting 0% and 100% levels or no limitation of entering values for multiple times within one step of Calibration Mode. Signal level is stored each time the respective UP or DOWN button is pressed.







STATUS INDICATOR LED

Combinations of the three front LEDs (LD1, LD2, LD3) indicate the transmitter's operating status by different flashing patterns.



















Examples are shown below.

 Amber LED	 OFF
 Green LED	 ON
 Red LED	 Blink

NORMAL OPERATION (RUN) MODE

LD1  LD2  LD3 	PC Configuration RUN Mode (Option A) The transmitter is configured via PC and is in normal operating conditions.	LD1  LD2  LD3 	DIP SW Configuration RUN Mode The transmitter is configured via DIP SW and is in normal operating conditions.
--	--	--	---

ERROR MODE

LD1  LD2  LD3 	System Error Indicates the CPU's communication error.	LD1  LD2  LD3 	DIP SW Error DIP SW configuration is inappropriate. Check the DIP SW setting referring to Tables 2 – 10.
LD1  LD2  LD3 	Burnout in PC Configuration Mode (Option A)	LD1  LD2  LD3 	Burnout in DIP SW Configuration Mode
LD1  LD2  LD3 	Output Saturated in PC Configuration Mode (Option A) The output is below -15% or above +115%.	LD1  LD2  LD3 	Output Saturated The output is below -15% or above +115%.



Fuji Electric France S.A.S.

46, Rue Georges Besse - Z I du Brézet - 63 039 Clermont-Ferrand cedex 2 FRANCE

France : Tél. 04 73 98 26 98 - Fax 04 73 98 26 99

International : Tel. (33) 4 7398 2698 - Fax. (33) 4 7398 2699

E-mail : sales.dpt@fujielectric.fr – Web : www.fujielectric.fr