

"FCX-AII-V5" SERIES TRANSMITTERS

Type : FKC...5

FKG...5, FKP...5

FKA...5, FKH...5

FKE...F

FKD, FKB, FKM...F

FKP, FKH...F

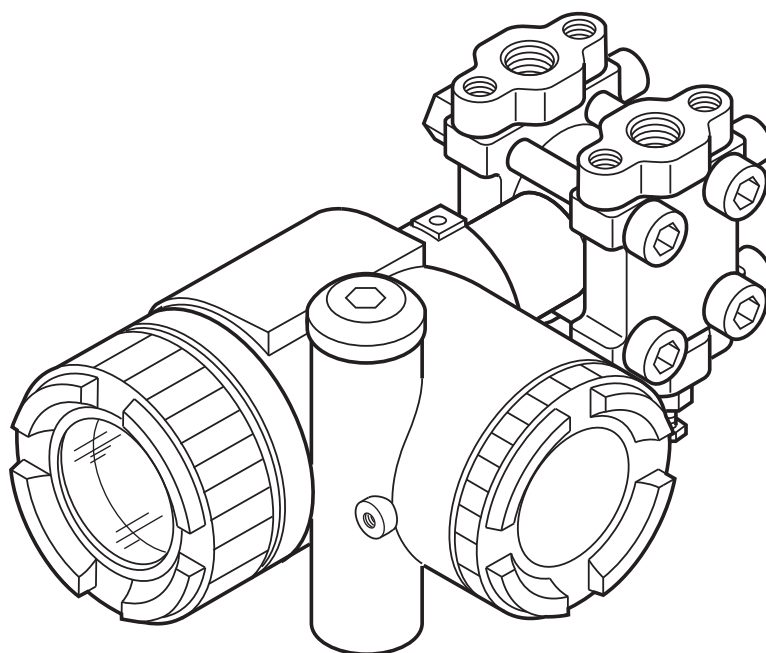



CAUTION :

Rotating the upper assembly part :

The upper assembly (housing and electronic unit) can be rotated by 90° left or right just by removing the 3 hexagonal screws.

If the assembly parts must be turned over than 90°, or if the position is already amended since the delivery by Fuji, it's necessary to remove the electronic unit from the housing and disconnect the flatcable from the electronic measuring cell before turn the housing.

If necessary, amend the flatcable's position connecting electronic unit and measuring cell, after fit the different parts.

Failure to observe this may lead to the deterioration of the flat cable, which is not covered by the manufacturer's warranty.

INTRODUCTION

First read this instruction manual carefully until an adequate understanding is required, and then proceed to installation, operation and maintenance of the FCX-AIIV5 series transmitter. The specifications of the transmitter will be changed without prior notice for further product improvement.

Modification of the transmitter without permission is strictly prohibited. Fuji will not bear any responsibility for a trouble caused by such a modification.

This instruction manual should be kept by a person who is actually using the transmitter.

After reading this manual, keep it at a place easier to access.

This manual should be delivered to the end user without fail.

For detail specifications and outline diagrams, refer to the specifications supplied separately.

Our pressure transmitters have been designed to meet international standards and directives. It is necessary to read carefully the manual before use these transmitters, to familiarize yourself with the installation, wiring processes, wiring and all operations and maintenance.

The technical information is detailed in each "Technical Specification" for each version of the transmitters.

Carefully read the instructions ATEX "HD FCXAII 102" for any use of sensors in dangerous areas.

The instrument nameplate as shown below is attached on the housing of this transmitter.

Before use, make sure the contents of the nameplate agree exactly with your specifications.

FCX-AII Tag No. ①		FE	
Model ② _____	_____	⑩ ⑪ ○	○
③ _____	_____		
Range Limit ④ _____	_____		
○ Power Supply ⑤ _____	_____		
Output ⑥ _____ OAN ⑫ _____	_____		
M.W.P ⑦ _____ Mfd ⑨ _____	_____		
Ser.No. ⑧ _____	_____		
CE			
IP66/67			
Fuji Electric France S.A.S. F-63039 Clermont-Ferrand			
338B352			

- 1 Tag number
- 2 Model
- 3 Transmitter type (see corresponding "technical datasheet")
- 4 Range
- 5 Power supply
- 6 Output
- 7 Maximum working pressure (MWP)
- 8 Serial number
- 9 Manufacturing date
- 10 Hazardous locations description
(See the "safety instruction" for the Pressure transmitter localised in the dangerous area)
- 11 2014/68/EU G1 TAMB. MIN. -40°C/ MAX. +85°C WITHOUT OPTIONS.
For equipments specified category III or IV, G1 = for use with all kinds of fluid
- 12 Order Acknowledgment Number

ELECTROMAGNETIC COMPATIBILITY

All FCX-All series of pressure transmitters are in conformity with the provision of the EMC Directive 2014/30/EU on the harmonization of the laws of the Members States relating to electromagnetic compatibility.

All these models of pressure transmitters are in accordance with the following harmonized standards :

- **EN 61326-1** (*Electrical equipment for measurement, control and laboratory use - EMC requirements - Part 1: General requirements.*)
- **EN 61326-2-3** (*Particular requirements - Test configuration, operational conditions and performance criteria for transducers with integrated or remote signal conditioning.*)

Emission limits (according to EN 55011 / CISPR 11, Group 1 Class A)

Frequency range (MHz)	Limits	Result
30 to 230	40 dB (µV/m) quasi peak, measured at 10 m distance	Passed
230 to 1000	47 dB (µV/m) quasi peak, measured at 10 m distance	

Immunity





Phenomenon	Test value	Standard	Required Performance criteria	Result of criteria
Electrostatic Discharge	±4 kV (Contact) ±8 kV (Air)	EN/IEC 61000-4-2	B	A
Radiated, Electromagnetic Field	10 V/m (0.08 to 1.0 GHz) 3 V/m (1.4 to 2.0 GHz) 1 V/m (2.0 to 2.7 GHz)	EN/IEC 61000-4-3	A	A
Fast transients (burst)	2 kV (5/50 ns, 5 kHz)	EN/IEC 61000-4-4	B	A
Surge Transients	1 kV Line to line 2 kV Line to ground	EN/IEC 61000-4-5	B	A
Conducted RF Disturbances	3 Vrms (150 kHz to 80 MHz) 80% AM @ 1 kHz	EN/IEC 61000-4-6	A	A
Power Frequency Magnetic Field	30 A/m (50 Hz, 60 Hz)	EN/IEC 61000-4-8	A	A

Performance criteria (A & B): according to IEC 61326

CLASSIFICATION OF SAFETY INSTRUCTIONS

First of all, read carefully the “Safety instructions” for your own safety and for correct use of the transmitter.

- The risks related to a non-respect of the instructions are prioritized as follow :

 DANGER	Risk of death or sever injury if the safety instructions are not followed.
 CAUTION	In case of wrong handling probable injury or physical damage can happen.
 PROHIBITION	Important instructions to be respected.
 INDICATION	General observations concerning the product, product handling and correct use of the transmitter.

IMPORTANT RECOMMENDATIONS

Storage for a long period

If the Pressure transmitter is not mounted rapidly on site after the delivery, please store the transmitter in a dry room at normal temperature and humidity (25°C and 60% RH). Keep it on the original packaging if possible.

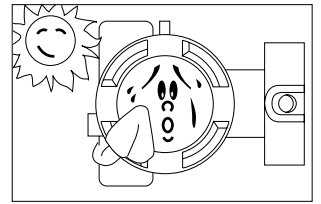

For installation, select an appropriate place

Site at location with minimal vibration, dust and corrosive gas

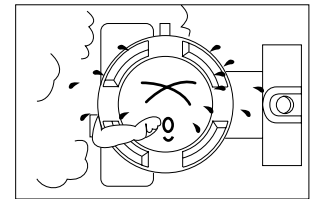

At a place allowing an adequate space for check-up

Site at location large enough to allow maintenance and checking.

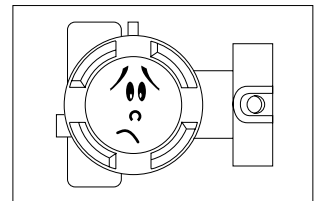

Mounting position

Mount to a pipe horizontally or vertically.

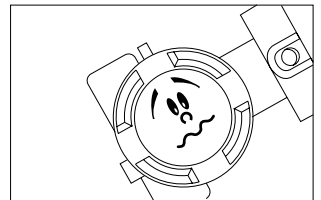

Attention to overload

Do not apply a pressure outside the specified range.

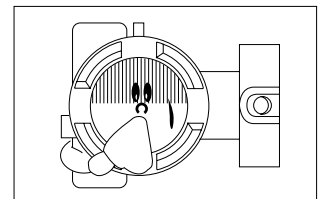

Others

Besides the above, be sure to observe the cautions given in this manual.

INTRODUCTION	2
ELECTROMAGNETIC COMPATIBILITY	3
CLASSIFICATION OF SAFETY INSTRUCTIONS	4
IMPORTANT RECOMMENDATIONS	5
1. OUTLINE	7
2. OPERATING PARTS AND THEIR FUNCTIONS	8
3. INSTALLATION AND PIPING	11
3.1 Installation	12
3.2 Piping	16
3.2-1 Piping of differential pressure and flow transmitters (FKC)	16
3.2-2 Piping of gauge and absolute pressure transmitters (FKG/FKP or FKA/FKH)	20
3.2-3 Piping of direct mount : absolute (FKH) and gauge pressure transmitters (FKP)	22
3.2-4 Piping of level transmitter (FKE)	24
3.2-5 Piping of remote seal(s) type transmitters (FKD, FKM, FKB)	27
3.2-6 Piping of remote seal types absolute and gauge transmitters	30
4. WIRING	32
4.1 Wiring procedure	33
4.2 Power voltage and load resistance	35
4.3 Grounding	35
5. START UP AND SHUTDOWN	36
5.1 Preparation for Start up	36
5.2 Operation	37
5.3 Shutdown	38
6. ADJUSTMENT	39
6.1 Adjustment procedure using the external adjusting screw	39
6.1-1 Zero adjustment by the screw	39
6.1-2 Span adjustment by the screw	40
6.2 Adjustment procedure by local configurator unit with LCD display	41
6.2-1 Menu list	42
6.2-2 Switching menus	43
6.2-3 Operating procedure	44
6.3 Adjustment with hand held communicator FXW	70
6.3-1 Connection of FXW	70
6.3-2 Start up of the FXW	71
7. MAINTENANCE	92
7.1 The following verifications are suggested by the manufacturer	92
7.2 Troubleshooting	93
7.3 Replacement of defective parts	94
7.4 Adjustment after replacement of amplifier or measuring cell	101
A1. BUILT-IN ARRESTOR	102
A2. CALIBRATION	104
A3. PARAMETER SETTING PRIOR TO DELIVERY	106
A4. HART® COMMUNICATION FUNCTION	107
A5. SPARE PARTS	111

The FCX-A2 V5 series transmitter accurately measures the differential pressure, level of liquid, gauge pressure or absolute pressure, and transmits a proportional current signal of 4 to 20mA DC. This transmitter can be used for flowrate, level, density measurement and other application using differential pressure measurement.

The transmitter utilizes a unique micromachined capacitive silicon sensor with state-of-the-art microprocessor technology to provide exceptional performances and functionalities.

The transmitter is compact and light, provide high accuracy and reliability.

Transmitter settings (such as range and damping time constant, etc.) can be changed from an HHC (Hand Held Communicator) or with an optional LCD digital display.

Local digital adjustment of zero and span are possible from outside screw on the electronic housing.

Measuring principle

The operating principle of the FCX-A2 V5 serie transmitters is shown in the below block diagram. The input pressure is changed into an electrostatic capacitance in the detecting unit.

The change proportional to the pressure undergoes conditioning and amplification in the transmission unit, and is then output as a current of 4 to 20mA DC

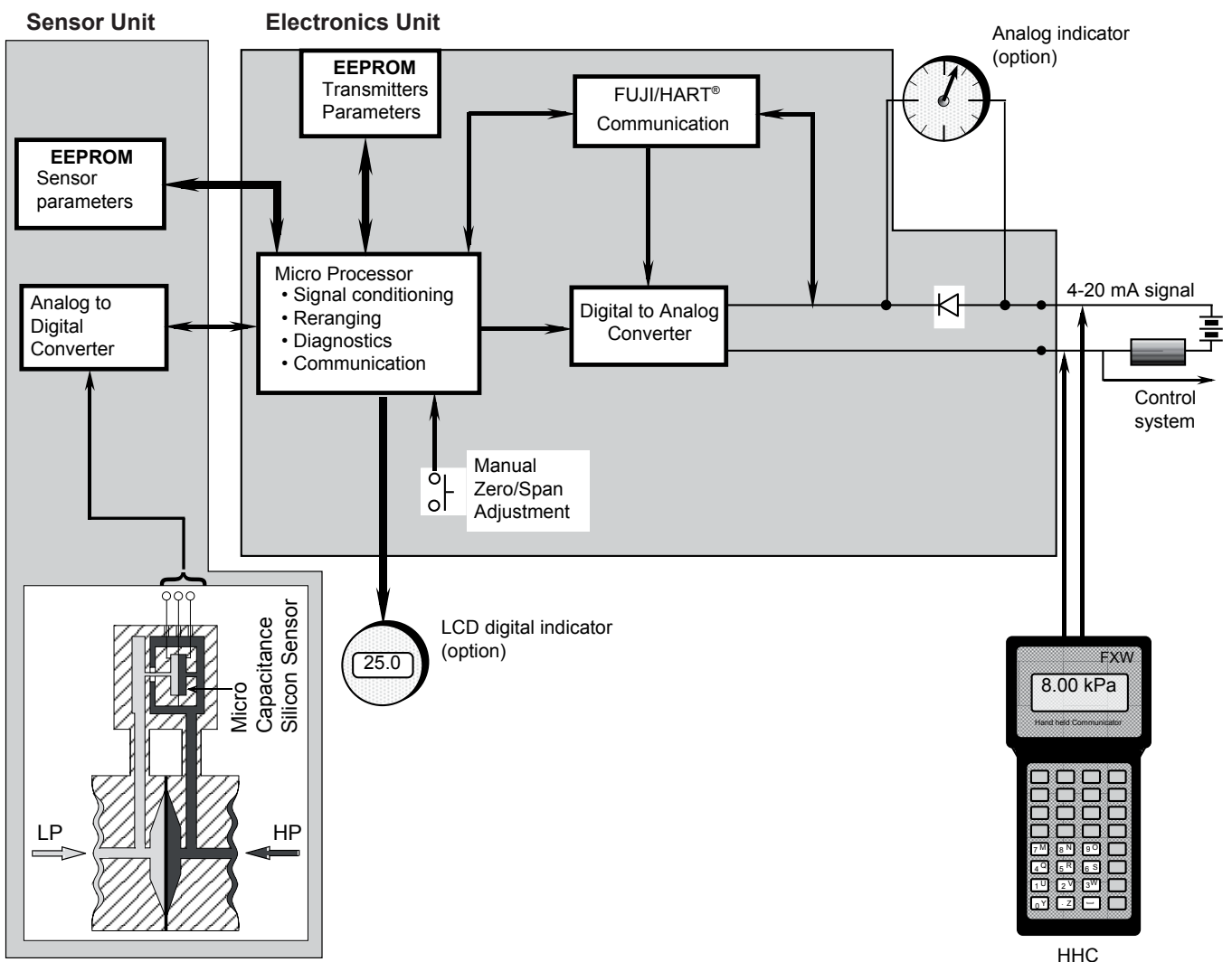

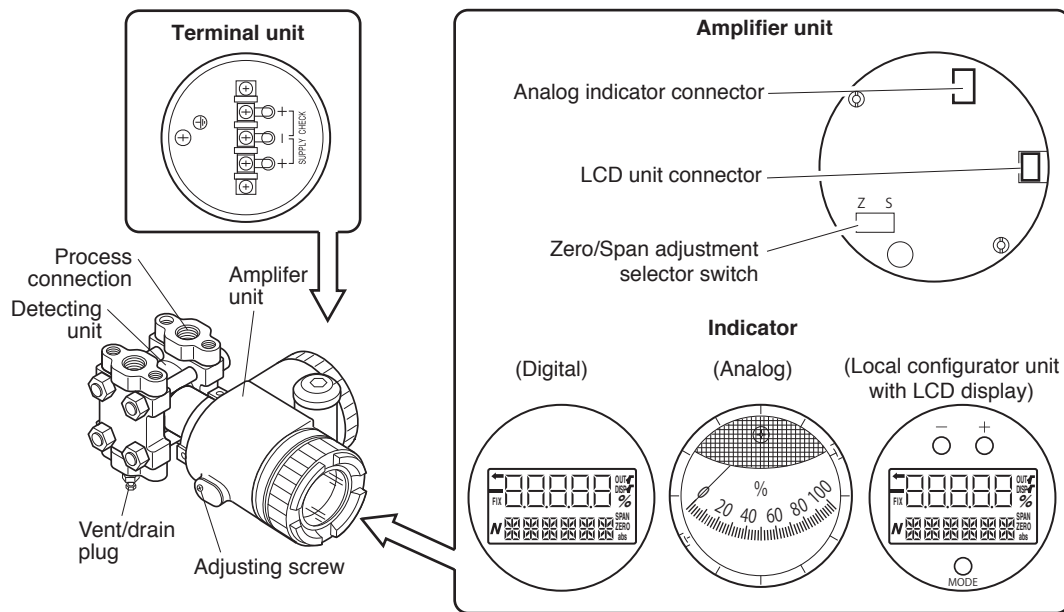

Description of FCX-A2 V5 serie transmitters

Part name	Description
Detecting unit	Detects pressure, differential pressure or level of liquid.
Amplifier unit	Converts the detected signal into an output signal.
Vent/drain plug	Used for gas discharge or draining.
Process connection	Connects impulse pipes from the process.
Electrical connection	Connects the output cable.
Zero Adjusting screw	Used for adjustment.
Connection unit	Connects an input-output line and ground wire

Amplifier Unit

Part name	Description
Analog indicator connector	Used for connecting an analog indicator.
LCD unit connector	Used to connect the digital indicator or the local configurator unit with LCD display.
Indicator (option)	The analog or digital indicator, or the local configurator unit with LCD display can be mounted.
Zero/Span adjustment selector switch	Used to select the function (zero/span) to be adjusted by the external adjusting screw.

Terminals

Symbol	Description
	Connects the output cable.
	Used for checking the output or connecting an analogic indicator or a remote indicator
	An external terminal used for grounding.



Mode indicating function of digital indicator

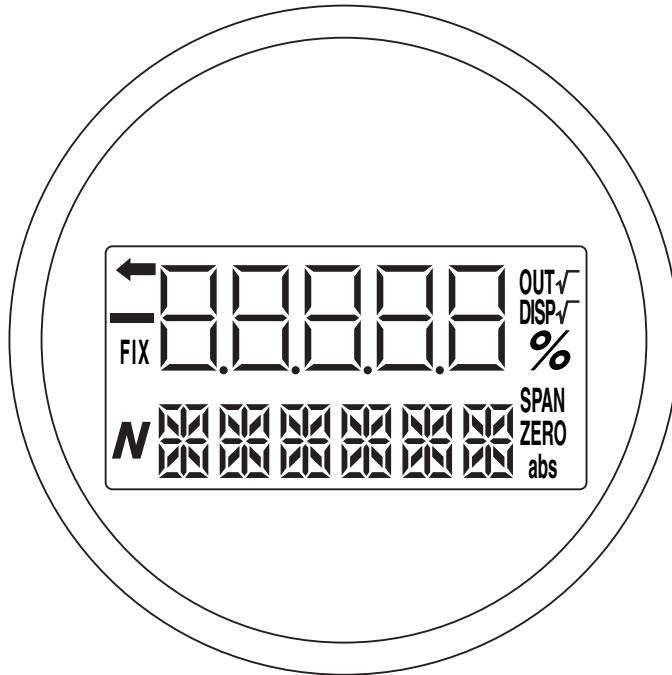

Mode indication

Mode	When indicated	When not indicated
%	% output	Actual scale
ZERO	Possible external zero adjustment	External zero adjustment not possible
SPAN	Possible external span adjustment	External span adjustment not possible.
DISP $\sqrt{\quad}$	Digital indicator $\sqrt{\quad}$ display	Digital indicator LIN display
OUT $\sqrt{\quad}$	$\sqrt{\quad}$ output	LIN output
FIX	Fixed current mode	Measurement mode
←	The transmitter is in operation (blinking).	The transmitter is not in operation.
abs	Absolute pressure	Gauge pressure
-	Output value < Zero	Output value ≥ Zero
N	(a part of unit indicator)	

Modes of the local configurator unit with LCD display and functions of the 3 push button key switches

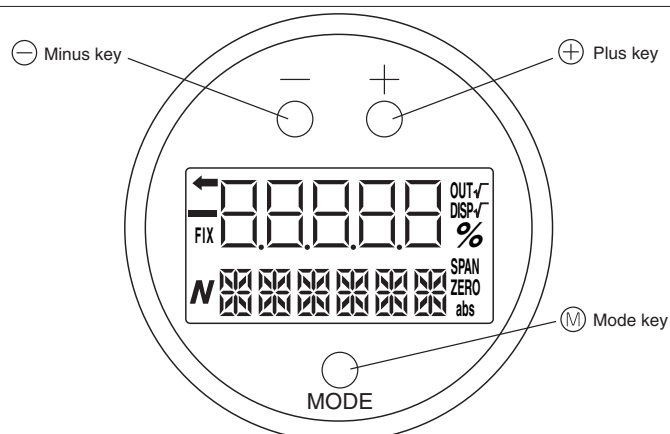

Normal mode (normal mode for indicating a measured value)



* For status indication in the normal mode, refer to the previous section "Mode indicating function of digital indicator."

Setting mode (functions of the 3 push button key switches)

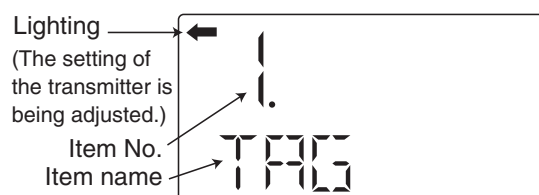

Functions of the 3 push button key switches

Name	Main function
Ⓜ Mode key	Switches between the normal and setting modes.
⊖ Minus key	Changes an item No. or item name to the minus (decrease) direction.
⊕ Plus key	Changes an item No. or item name to the plus (increase) direction.

* Refer to Section "Adjustment procedure by the local configurator unit with LCD display" for details.

3

INSTALLATION AND PIPING

Type	Ambient temperature limit	Process temperature limit	Span limit	Static pressure limit	Technical datasheets
Differential pressure	-40 to 85°C	-40 to 120°C (silicone oil)	10 mbar	-1 to 32 bar	EDSF6-134
			60 mbar	-1 to 100 bar	
		-20 to 80°C (fluorinated oil)	320 mbar	-1 to 160 bar (option : 420 bar)	
			1300 mbar	-1 to 160 bar (option : 420 bar)	
		5 bar	-1 to 160 bar (option : 420 bar)		
		30 bar	-1 to 160 bar (option : 300 bar)		
		200 bar	-1 to 300 bar		
Gauge Pressure	-40 to 85°C	-40 to 100°C (silicone oil)	1,3 bar	-1 to 1,3 bar	EDSF5-92 and EDSF5-98
			5 bar	-1 to 5 bar	
			30 bar	-1 to 30 bar	
		-20 to 80°C (fluorinated oil)	100 bar	-1 to 100 bar	
			500 bar	-1 to 500 bar	
Absolute Pressure	-40 to 85°C	-40 to 85°C	0,16 bar abs	0 to 0,16 bar abs	EDSF5-91 and EDSF5-97
			1,3 bar abs	0 to 1,3 bar abs	
			5 bar abs	0 to 5 bar abs	
			30 bar abs	0 to 30 bar abs	
			100 bar abs	0 to 100 bar abs	
Level and remote seal(s)	-40 to 85°C	See note*	60 mbar	According PN/lbs of remote seal	EDSF7-68 EDSF6-05 and EDSF6-06
			320 mbar		
			1300 mbar		
			5000 mbar		
			30000 mbar		
			100 bar		
			200 bar		
			500 bar		

* Refer to "technical datasheets" about details of process temperature limits of the transmitters.
For specific transmitters with static pressure > 420 bar, ask Fuji Electric.



INDICATION

Protect the transmitter with a security device when the existing application conditions require it. The transmitter should be installed remote from the measuring point in the case that the process temperature is too high.

3.1 Installation

During the unpacking of the transmitter, check the conformity of the transmitter and all the accessories.

Before installation, the customer must check the compatibility of the wetted parts for the application. The possibility of a modification of the process has to be taken in account by the customer. The transmitter can be installed on a 2" tube or wall mounted.

The level transmitter FKE has a remote seal and can be installed directly on a counter flange.

Note :

For the wall mounting, the customer has to supply the M8 bolting.

Please refer to the data sheets for the outline dimension drawings of the transmitters.



DANGER

An explosion proof certified transmitter has to be used on a process with explosive gas otherwise there will be a risk of accident (explosion, fire etc)



INDICATION

If the transmitter is not used soon after delivery, then leave it packed and store it in a room at the normal temperature and humidity (25°C <77°F>, 60% RH).



DANGER

- The transmitter is heavy. Be careful when handling it.
- The indicated installation and the wiring conditions of the transmitter must be strictly followed.
- A wrong manipulation can be the reason of a disfunction of the transmitter.
- During installation, make sure that no part which could be the reason of the disfunction or a danger is located inside the electronics housing.
- When the transmitter is installed in a flame proof area :
 - The local indicator position must not be changed
 - The position of the electronics housing must not be changed
- The isolating valves and manifold must correspond to the maximum pressure in the pipe. If the valves and the connections do not correspond to the max pipe pressure, there will be a risk of gas leakage or dangerous fluid.
- The pipes need to be according the process temperature and the pressure standards.
- Membrane are very sensitive. Be careful during the manipulation.
- Do not bend excessively the capillary

Bracket mounting

Mount the bracket on the transmitter as shown below.

FKC, FKG and FKA models

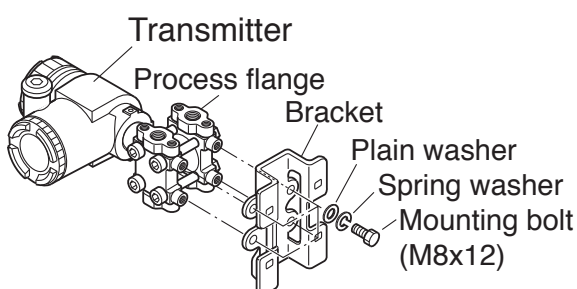

FKD, FKB and FKM models

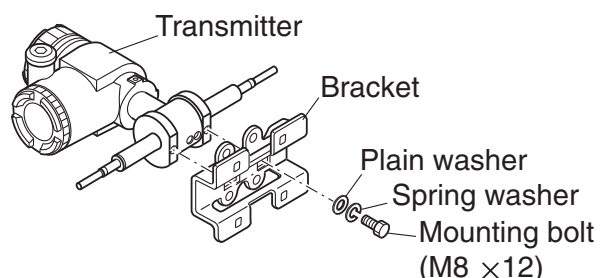

FKP and FKH models

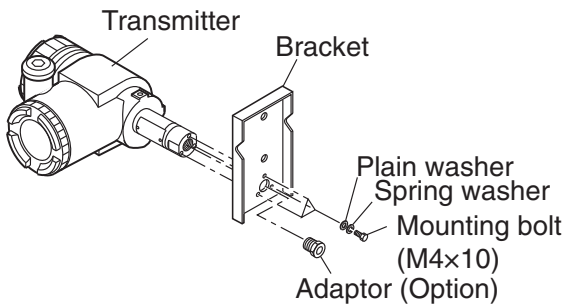

Process mounting

• Pipe mounting

FKC, FKG and FKA models

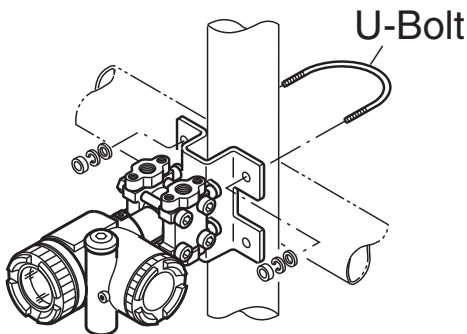

FKD, FKB and FKM models

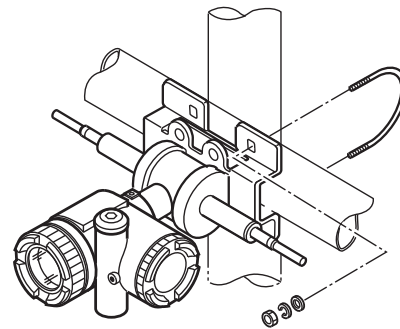

• Wall mounting

Fasten the transmitter to the wall with M8 bolts.

FKP and FKH models

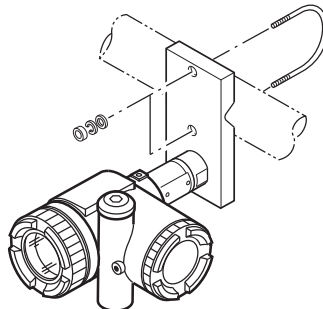

(1) Fasten the transmitter to a vertical or horizontal pipe using the supplied U-bolt (Tightening torque approximately 15 Nm (1.5 kgfm) <11ft-lb>).

(2) Use a pipe of outside diameter 2" (ø60.3 mm)

• Flange mounting

Position the remote seal of the transmitter in front of the counter flange.

Fix the transmitter to the flange using the adapter boltings

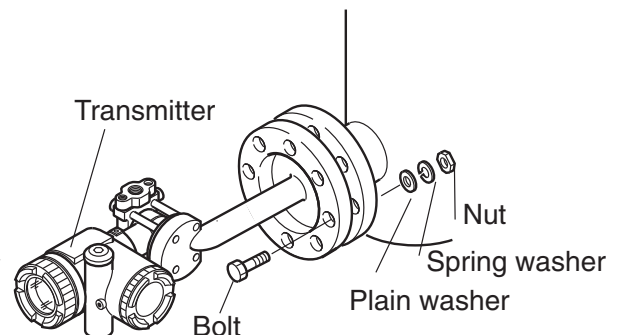

Change of electronics housing position



DANGER

Avoid the following procedure in an explosionproof area.

The wiring or the access can be difficult according to the position of the transmitter. The electronics housing position can be modified by turning it by steps of 90 or 180 degrees.

The electronics housing is fixed by hexagonal socket bolts (M6 x 12). Loosen the bolts and turn the electronics housing to the right or left hand side; fasten the fixing screws after this operation again



PROHIBITION

Never turn the electronic housing over than 90° without disconnect the flat cable (possibility to break the flat cable from the electronic measuring cell).

If the transmission unit has been turned excessively without removing the electronics unit, straighten the flat cable which connects the electronics unit in the transmission unit and the detecting unit, and set the transmission unit again.

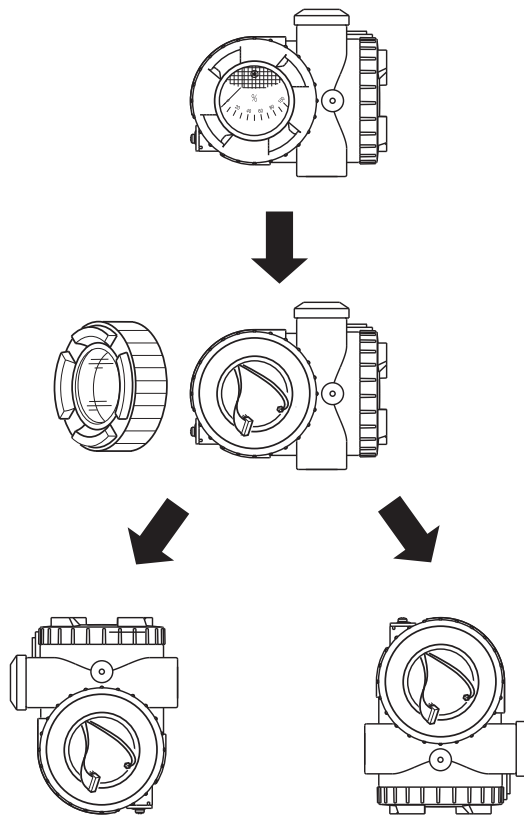

Change of indicator position



DANGER

Avoid the following procedure in an explosionproof area.

The digital indicator can be turned $\pm 180^\circ$ in 90° increments because it is connected with a pin plug.

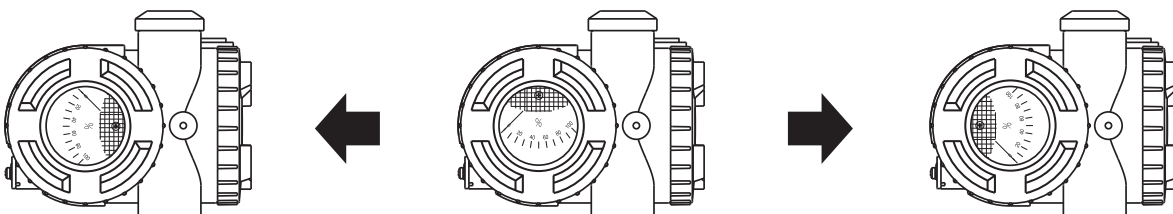

Check space

Ensure a space of about 500mm against the cover in order to facilitate the maintenance.

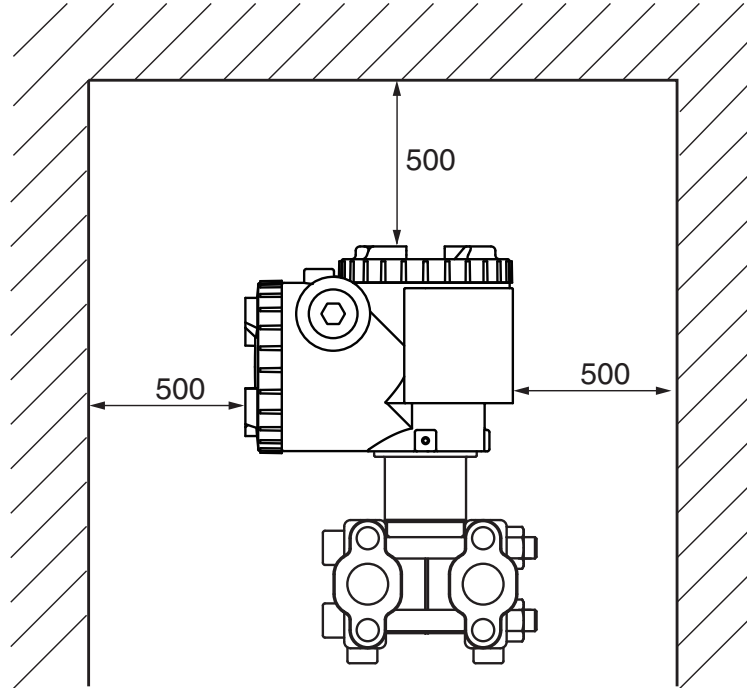

Change of vent/drain plug position

Unscrew slowly grasp the hexagon part of vent/drain plug with an allen key.
Put a new seal tape (4 to 8 rounds) and mount the vent/drain plugs in the position you want applying the tightening torque :

Tightening torque : 25Nm (2.5kgf m) <18ft lb>

Process connection

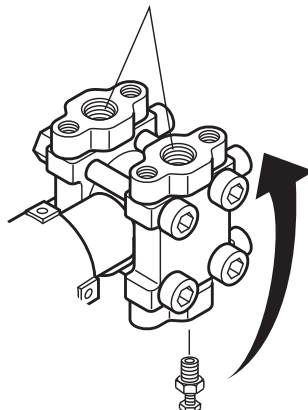

3.2 Process piping

The piping connection must respect some rules to have an accurate measurement :

General recognitions are :

- 1) Transmitter must be mounted below the process piping for liquid and steam measurement.
- 2) Transmitter must be mounted above the process piping for gaz measurement.



Main valve or manifold used for piping should be selected with the maximum pressure of the process taken into account (piping parts such as main valve, etc. should be furnished by user). If the main valve and other parts do not meet the rating, it may result in leakage of gas or liquid which could lead to a hazard.

3.2.1 Differential pressure and flow transmitters (type: FKC)

Check of "High" and "Low" pressure sides of transmitter

The "High" Pressure side is indicated by "H" and the "Low" pressure side by "L" on the cell neck

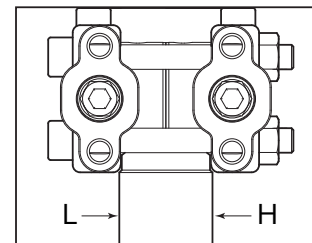

Removal the protective cap

The process connection ports of the transmitter and manifold valve are fitted with protective caps. Before piping, be sure to remove the caps. When removing the caps, carefully protect the threaded portion and sealing face from damage.

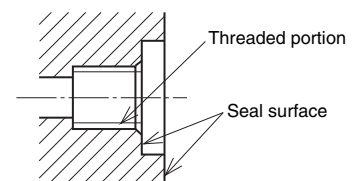

Connect the transmitter to impulse pipes

- (1) When using the manifold valve, it should be fixed to the transmitter by tightening four oval flange set bolts (7/16-20UNF), and then the impulse pipe should be connected to the manifold valve. Tightening torque of 7/16-20UNF mounting bolt should be 30 to 40 Nm (3 to 4 kgf m).
- (2) If a manifold is not used, the impulse pipes can directly be screwed into the transmitter. If thread size does not match between the transmitter and impulse pipes, an oval flange should be used.

Position of process connection

The position of the process connection is determined by the relationship between the condition, characteristics and measuring point of the process fluid.

Follow the process position according to the process :

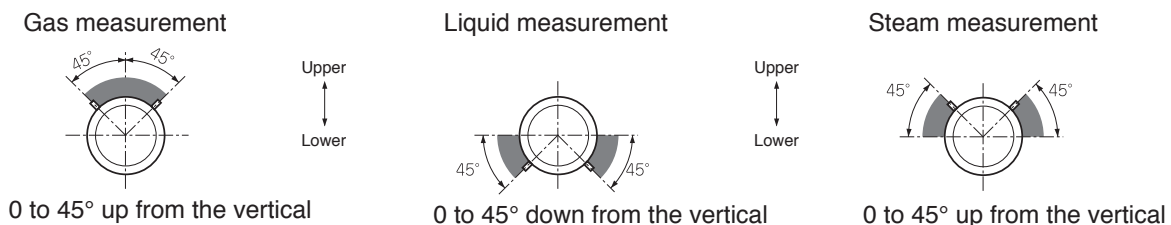

Recommendation for process connection

1- Liquid flow measurement (in case of liquid)

Place the transmitter below the process pipe

Make piping so that gas in the impulse pipe is not delivered to the transmitter, and incorporate gas reservoirs as required..

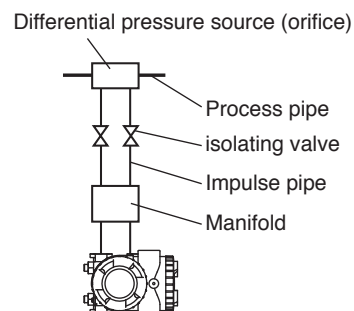

2- Steam flow measurement

Set two condensers at the same height between the transmitter and the primary element.

Fill the pipe between the condensers and transmitter with water.

Installation of a drain is necessary

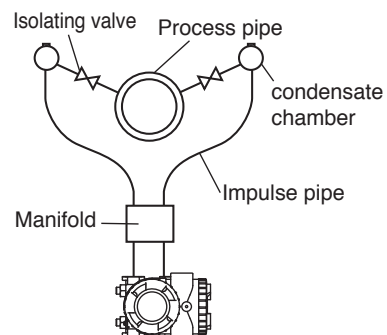

3- Gas flow measurement

Place the transmitter above the process pipe. If the process temperature is high, please use a condensate chamber like for steam

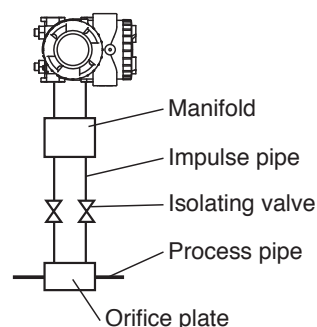

4- Pressure measurement for liquid

The transmitter must be below the process pipe.

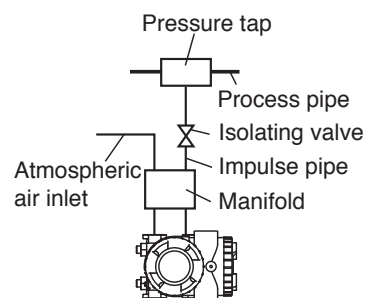

(1) During valves and manifold installation, please make sure that no dust enters through the atmospheric air inlet.

(2) If pressure measurement is low (below 10kPa (1000mmH₂O)), the following should be considered.

- Pressure variation due to wind around atmospheric air inlet
- Temperature variation near process connection
- Difference in atmospheric pressure between process connection and transmitter location.

To overcome this, provide atmospheric pressure-side pipe with a proper orifice and consider accommodating the transmitter and atmospheric air inlet in a box.

5- Pressure measurement for gas

Place the transmitter above the process pipes to preventing condensation in the impulse pipe and in the measuring

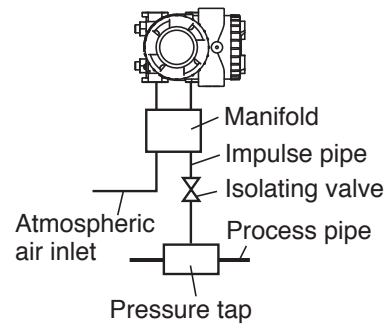

6- Level measurement

(1) Reference column filled

For measurement, connect the highest liquid level of tank with the low pressure side of transmitter, and the lowest liquid level of tank with the high pressure side of transmitter.

The reference column (connected to the highest level of tank) must be filled of fluid.

Level calculation formula

$$\text{LRV} : \rho H_2 - \rho_0 H_1$$

$$\text{URV} : \rho H_2 + \rho_1 h - \rho_0 H_1$$

ρ_0, ρ, ρ_1 : Density

H_1, H_2 : Liquid level,

h : Liquid level change

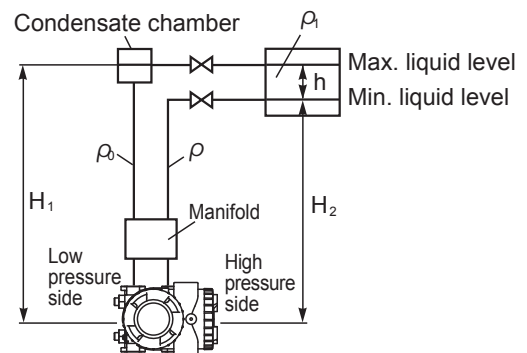

(2) Reference column empty

For an open tank, leave the low pressure side of transmitter open to atmosphere.

Level calculation formula

$$\text{LRV} : \rho H_1$$

$$\text{URV} : \rho H_1 + \rho_1 h$$

ρ, ρ_1 : Density

H_1 : Liquid level,

h : Liquid level change

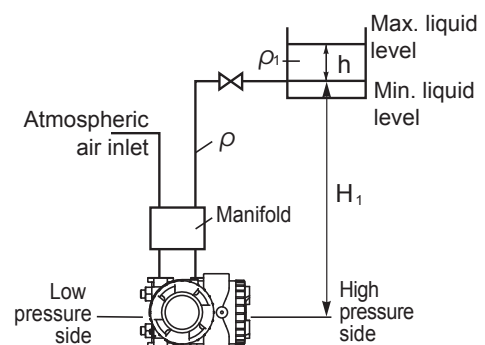



Cautions on impulse piping

- For liquid, the impulse pipes should have a downward slope of 1/10 or more between the process connection and the transmitter to prevent accumulation of gas, etc. in the detecting unit.
- For gas, the impulse pipes should have a upward slope of 1/10 or more between the process connection and transmitter to prevent accumulation of liquid or condensat, etc. in the detecting unit.
- Avoid any sharp bends in impulse pipe which may cause gas or liquid to accumulate in the impulse pipe.
- Do not apply an excessive force to impulse pipe during the connection.
- Install condensate chambers or vent drain when impulse pipes can not be inclined.
- The impulse pipes used should be suitable for the working temperature, pressure standards.
- During installation, avoid mechanical constrains of the transmitter connections.
- In case of external degradation (corrosion, overflow, shock ... etc) or in case of fire, the concerned transmitter must be checked before commissioning.
- To avoid the deterioration of the transmitter mounted externally, it will be mounted in a box protection.
- The transmitter should never be exposed to fire. In case of fire, the transmitter characteristics need to be checked before started up. The transmitter must not be reused if it has been partially or totally exposed to fire and heat.

- **Freeze protection.**

If the fluide can freeze, the transmitter and the impulse pipe must be warmed up with steam or a heater.

Do not exceed the temperature limits (measuring cell: 120°C maxi and transmitter: 85°C).

Even when the installations shut down the heat must be maintained, if not the transmitter and impulse pipes must be drained to prevent freezing.

3.2.2 Gauge and absolute pressure transmitters (types: FKG and FKA)

Remove the protective cap

The process connection port of the transmitter is fitted with a protective cap. Before piping, be sure to remove the cap. When removing the cap, carefully protect the threaded portion and sealing face from damage.

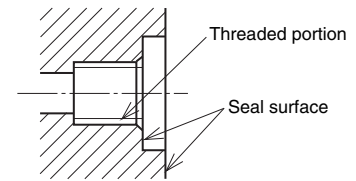

Connect the transmitter to impulse pipes

- When using the manifold valve, it should be fixed to the transmitter by tightening four oval flange set bolts (7/16-20UNF), and then the impulse pipe should be connected to the manifold valve. Tightening torque of 7/16-20UNF mounting bolt should be 30 to 40 Nm (3 to 4 kgf m).
- If manifold is not used, the impulse pipes can directly screwed into the transmitter. If thread size does not match between the transmitter and impulse pipes, an oval flange should be used. Tightening torque of 7/16-20UNF mounting bolt in an oval flange should be 30 to 40 Nm (3 to 4 kgf m).
- For an absolute pressure measurement, make sure that isolating valves or manifold can be designed for vacuum service.

Position of process connection

The position of the process connection is determined by the relationship between condition, characteristics and measurement point of process fluid.

Follow the process position according to the process :

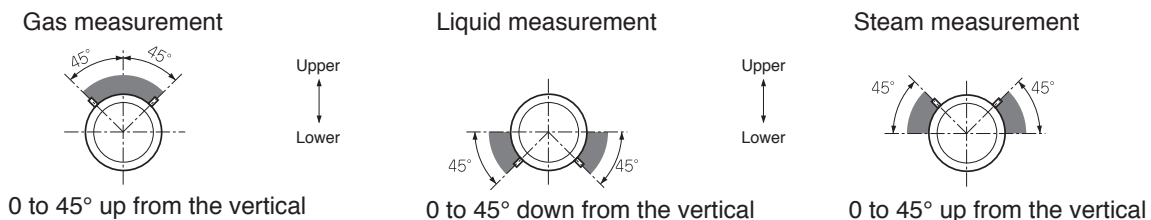

Recommendation for process connection

1- Liquid measurement

Place the transmitter below the process pipe.

Make piping so that gas in the impulse pipe is not delivered to the transmitter and incorporate gas reservoir as required.

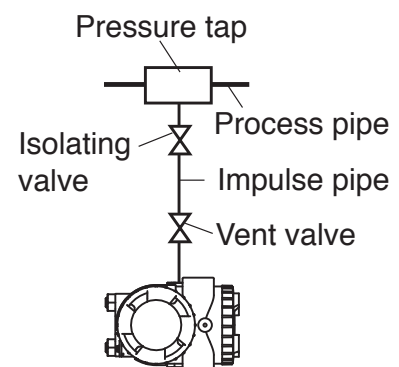

2- Steam measurement

A condensate chamber must be mounted between transmitter and process connection.

Fill the pipe between the condensate chamber and the transmitter with water.

The installation of a drain is necessary.

3- Gas measurement

Place the transmitter above the pressure source.

If high temperature, use condensate chamber like for steam.

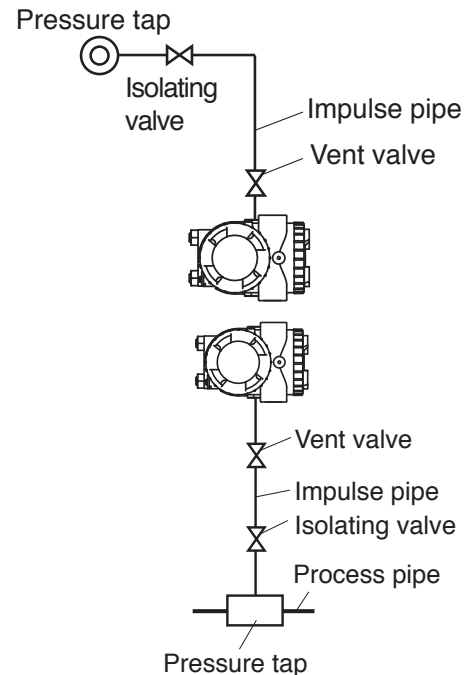

Cautions on impulse piping

- For liquid, the impulse pipes should have an downward slope of 1/10 or more between the process connection and the transmitter to prevent accumulation of gas, etc. in the detecting unit.
- For gas, the impulse pipes should have a upward slope of 1/10 or more between the process connection and transmitter to prevent accumulation of liquid or condensat, etc. in the detecting unit.
- Avoid any sharp bends in impulse pipe which may cause gas or liquid to accumulate in the impulse pipe.
- Do not apply an excessive force to impulse pipe during the connection.
- Install condensate chambers or vent drain when impulse pipes can not be inclined.
- The impulse pipes used should be suitable for the working temperature, pressure standards.
- During installation, avoid mechanical constrains of the transmitter connections.
- In case of external degradation (corrosion, overflow, shock ... etc) or in case of fire, the concerned transmitter must be checked before commissioning.
- To avoid the deterioration of the transmitter mounted externally, it will be mounted in a box protection.
- The transmitter should never be exposed to fire. In case of fire, the transmitter characteristics need to be checked before started up. The transmitter must not be reused if it has been partially or totally exposed to fire and heat.

• Freeze protection.

If the fluide can freeze, the transmitter and the impulse pipe must be warmed up with steam or a heater.

Do not exceed the temperature limits (measuring cell: 120°C maxi and transmitter: 85°C).

Even when the installations shut down the heat must be maintained, if not the transmitter and impulse pipes must be drained to prevent freezing.

3.2.3 Absolute pressure (FKH) and gauge pressure transmitters (FKP)

Remove the protective cap

The process connection port of the transmitter is fitted with a protective cap. Before piping, be sure to remove the cap. When removing the cap, carefully protect the threaded portion and sealing face from damage.

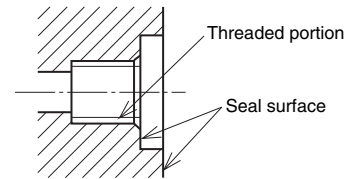

Connect the transmitter to impulse pipes

The piping can be connected directly to the process connection of the transmitter or via an oval flange. If an isolating valve is used, let it close until commissioning to prevent foreign objects from entering.

For an absolute pressure measurement, make sure that isolating valves or manifold can be designed for vacuum service.

Position of process connection

The position of the process connection is determined by the relationship between condition, characteristics and measurement point of process fluid.

Follow the process position according to the process :

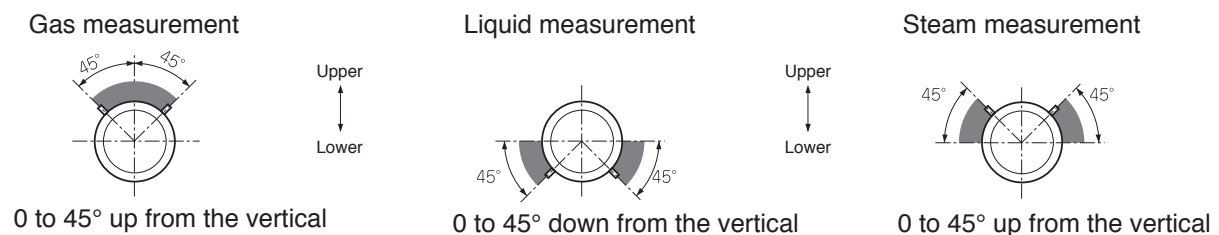

Recommendation for process connection

(1) Liquid measurement

Place the transmitter below the the process pipe.

Make piping so that gas in the impulse pipe is not delivered to the transmitter, and incorporate gas reservoirs as required.

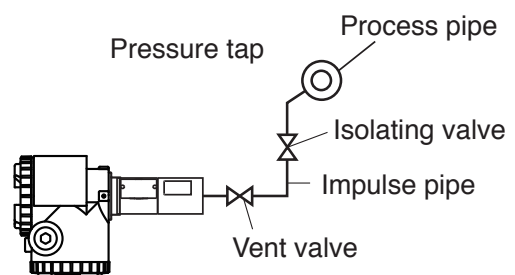

(2) Steam measurement

A condensate chamber must be mounted between transmitter and process connection.

Fill the pipe between the condensate chamber and the transmittimer with water.

The installation of a drain is necessary.

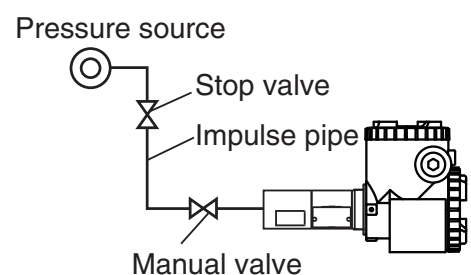

(2) Gas measurement

Place the transmitter above the pressure source.

If high temperature, use condensate chamber like for steam.

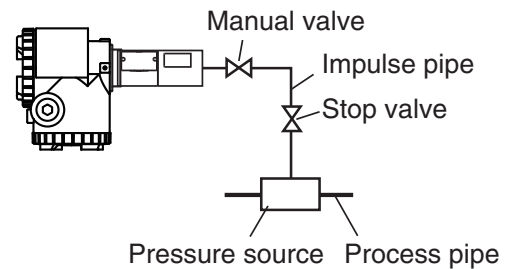

Cautions on impulse piping

- For liquid, the impulse pipes should have a downward slope of 1/10 or more between the process connection and the transmitter to prevent accumulation of gas, etc. in the detecting unit.
- For gas, the impulse pipes should have a upward slope of 1/10 or more between the process connection and transmitter to prevent accumulation of liquid or condensat, etc. in the detecting unit.
- Avoid any sharp bends in impulse pipe which may cause gas or liquid to accumulate in the impulse pipe.
- Do not apply an excessive force to impulse pipe during the connection.
- Install condensate chambers or vent drain when impulse pipes can not be inclined.
- The impulse pipes used should be suitable for the working temperature, pressure standards.
- During installation, avoid mechanical constrains of the transmitter connections.
- In case of external degradation (corrosion, overflow, shock ... etc) or in case of fire, the concerned transmitter must be checked before commissioning.
- To avoid the deterioration of the transmitter mounted externally, it will be mounted in a box protection.
- The transmitter should never be exposed to fire. In case of fire, the transmitter characteristics need to be checked before started up. The transmitter must not be reused if it has been partially or totally exposed to fire and heat.
- **Freeze protection.**
If the fluide can freeze, the transmitter and the impulse pipe must be warmed up with steam or a heater.
Do not exceed the temperature limits (measuring cell: 120°C maxi and transmitter: 85°C).
Even when the installations shut down the heat must be maintained, if not the transmitter and impulse pipes must be drained to prevent freezing.

3.2.4 Level transmitter (type: FKE)

Check of "High" and "Low" pressure sides of transmitter

The "High" Pressure side is indicated by "H" and the "Low" pressure side by "L" on the cell neck

The high pressure side is always equipped with flange and identified with H letter on the label.

The low pressure side is equipped with a fitting process and a drain plug.

Upon request, the low pressure can be connect with a seal (or remote seal).

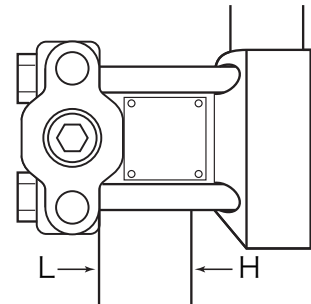

Seal on mounting flange face

When mounting the flange on the high pressure side, a gasket should be inserted between the flange of the transmitter and the flange of the tank.

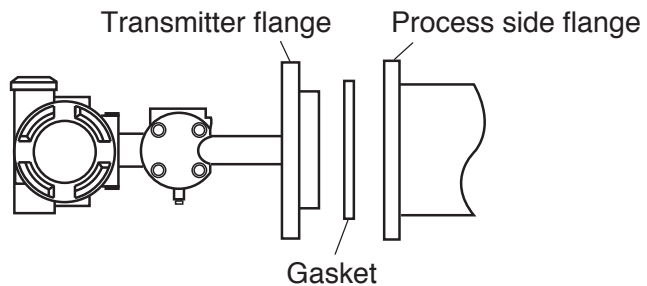

 CAUTION	<p>The seal must be chosen according type flange mounted on the transmitter. The internal diameter must be greater or equal to the diaphragm seal to not press it and effect the measure.</p> <p>Be careful to a potential leak who can effect the measure.</p>
---	---

Standard dimension of the diaphragme seal are :

Flange size	Ø diaphragm seal (mm)
DN80 / 3"	Stainless steel : 73
	special material : 89
DN100 / 4"	Stainless steel : 96
	special material : 89

For others flanges, consult Fuji Electric France.

Method for screwing the mounting flange

Tighten bolts of mounting flange and process flange in a diagonal order and about three cycles using the tightening torque corresponding to the screw used and according to the flange standard.

Remove the protective cap from process connection port

The process connection port of the transmitter is fitted with a protective cap. Before piping, be sure to remove the cap. When removing the cap, carefully protect the threaded portion and sealing face from damage.

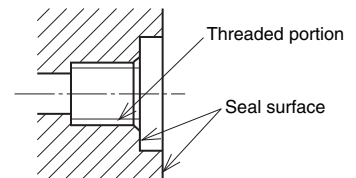

Connection of low pressure side and impulse pipe

The piping can be connected directly to the process connection of the transmitter or via an oval flange. If an isolating valve is used, let it close until commissioning to prevent foreign objects from entering.

Level measurement

(1) Level measurement on open tank

Leave the low pressure side of transmitter open to atmosphere.

Level calculation formula :

$$\text{LRV} : \rho H_1$$

$$\text{URV} : \rho (H_1 + h)$$

ρ : Measuring liquid density

H_1 : Liquid level between the flange axis and the mini level

h : Liquid level change

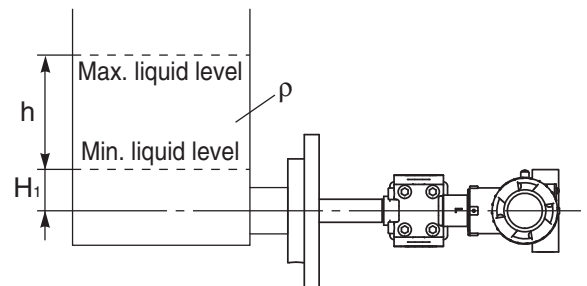

(2) Level measurement on close tank

1- In case of reference column

Connect the highest liquid level connection of tank to the low pressure side of transmitter, and the lowest liquid level connection of tank to the high pressure side (flange side) of transmitter.

Level calculation formula:

$$\text{LRV} : \rho H_1 - \rho_0 H_2$$

$$\text{URV} : \rho (H_1 + h) - \rho_0 H_2$$

ρ : Measuring liquid density

ρ_0 : Seal liquid density

H_1 : Liquid level between the flange axis and the mini level

h : Liquid level change

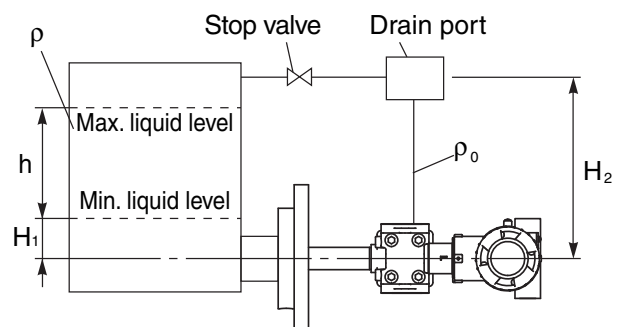

2- In case of reference column

Connect the highest liquid level connection of tank to the low pressure side of transmitter, and the lowest liquid level connection of tank to the high pressure side (flange side) of transmitter.

Level calculation formula

$$\text{LRV} : \rho H_1$$

$$\text{URV} : \rho (H_1 + h)$$

ρ : Measuring liquid density

H_1 : Liquid level between the flange axis and the mini level

h : Liquid level change

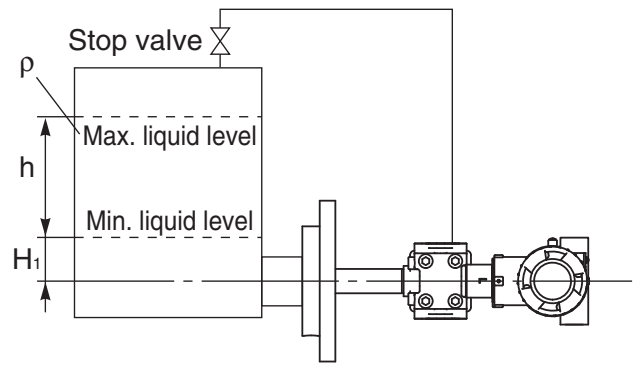

Cautions on installation

- H_1 must be more than half of the remote seal diaphragm diameter. Otherwise the measure will not be linear to the level as far as the diaphragm is not totally submerged
- In order to prevent vibration of the transmitter body and capillary from interfering with output, the transmitter body should be installed at a vibration-free place and the capillary should be fixed to a stable support.
- Do not scratch or shock the seal diaphragm by hitting hard object against it, for example. It would damage definitely the transmitter
- Do not apply an excessive force to the screw of flange during connection (respect the tightening torque according to pipe standard).

Freeze protection.

If the fluid can freeze, the transmitter and the impulse pipe must be warmed up with steam or a heater.

Do not exceed the temperature limits (measuring cell: 120°C maxi and transmitter: 85°C).

Even when the installations shut down the heat must be maintained, if not the transmitter and impulse pipes must be drained to prevent freezing.

3.2.5 Remote seal(s) type transmitter (FKB, FKD and FKM)

(1) Remote seal type differential pressure transmitter (FKD)

Check of high/low pressure sides of transmitter

The "High" Pressure side is indicated by "H" and the "Low" pressure side by "L" on the cell neck. High pressure side is always with a capillary or a rigid seal (direct mounting) allowing a remote seal connection.

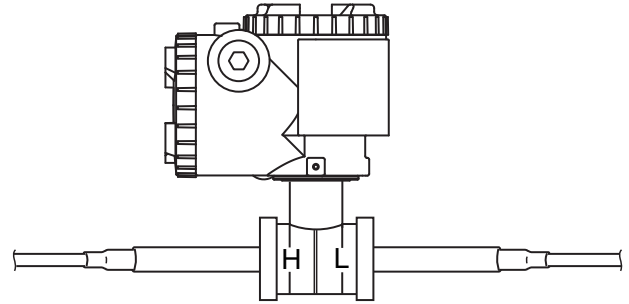

Seal on mounting flange face

When mounting the flange on the high pressure side, a gasket should be inserted between the flange of the transmitter and the flange of the tank.

Be careful to a potential leak who can effect the measure.

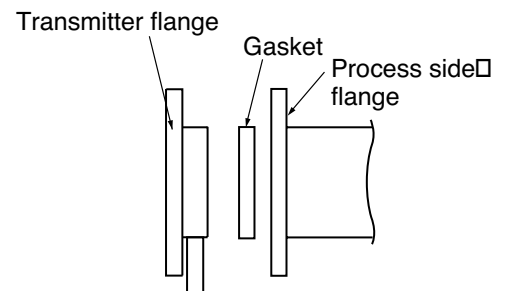

The seal must be chosen according type flange mounted on the transmitter. The internal diameter must be greater or equal to the diaphragm seal to not press it and effect the measure. Be careful to a potential leak who can effect the measure.

Standard dimension of the diaphragme seal are :

Flange size	Ø diaphragm seal (mm)
DN80 / 3"	SS : 73
	Special material : 89
DN100 / 4"	SS : 96
	Special material : 89

For others flanges, consult Fuji Electric France.

Method for screwing the mounting flange

Tighten bolts of mounting flange and process flange in a diagonal order and about three cycles using the tightening torque corresponding to the screw used and according to the flange standard.

Level measurement

(1) Level measurement on open tank

The low pressure side is open to atmosphere.

Level calculation formula:

Zero : $\rho E + \rho' h'$

Span : $\rho(E + h) + \rho' h'$

ρ : Measuring liquid density

ρ' : Seal diaphragm liquid density

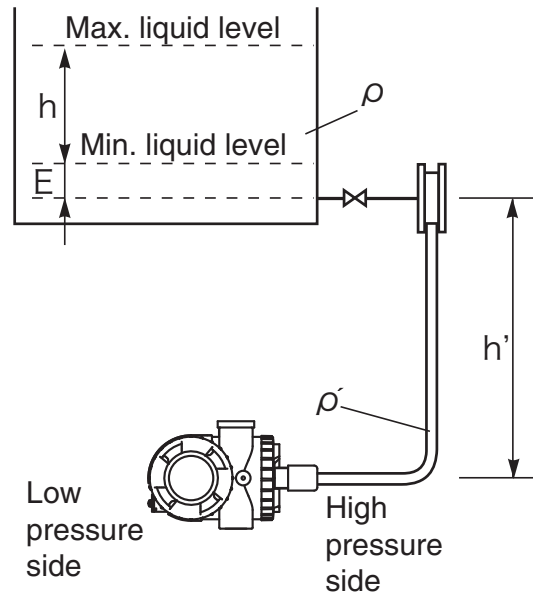

(2) Level measurement on close tank

Connect the highest liquid level connection of tank to the low pressure side of transmitter, and the low liquid level connection of tank to the high pressure side of transmitter

Level calculation formula:

Zero : $\rho.E - (E + h)$

Span : $\rho.h$

ρ : Measuring liquid density

ρ' : Seal diaphragm liquid density

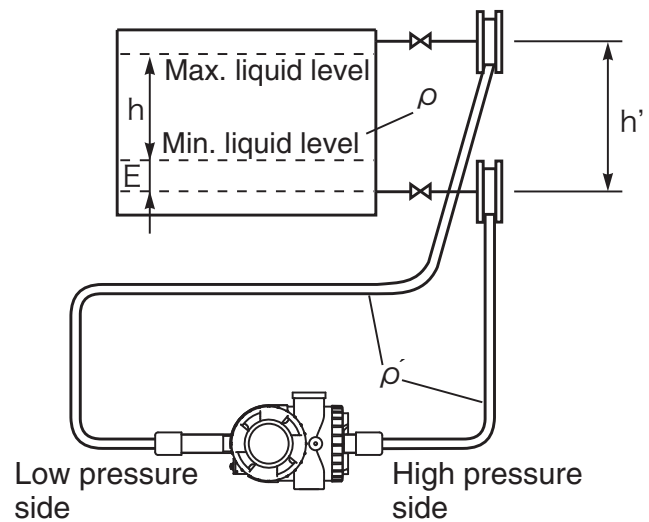

PROHIBITION

The transmitter body should be installed below the remote seal unit. This is mandatory where process pressure may become vacuum.

The oil density of the diaphragm seal can be done by Fuji Electric.
For information, the current values are as follows :

Filling oil	Density	Applications
Silicone	0,934	générales
	1,07	Haigh temperature, high temperature and et vaccum service, high temperature and absolute vaccum service
Fluorinated	1,84	Oxygen measurement

Caution when vacuum measurement



PROHIBITION

When process pressure is nearly vacuum pressure, the transmitter must be installed below the pressure connection (see fig.1)

If installation is like fig. 2 or 3, an additionnal negative pressure is done by H_0 of filling liquid in the capillaries between transmitter and the low pressure connection.

In this case, it is imperative to check that the resulting pressure of measurement cell of transmitter is greater than minimum pressure service (refer the technical specifications of the transmitter model used).

When in doubt, please consult Fuji Electric France.

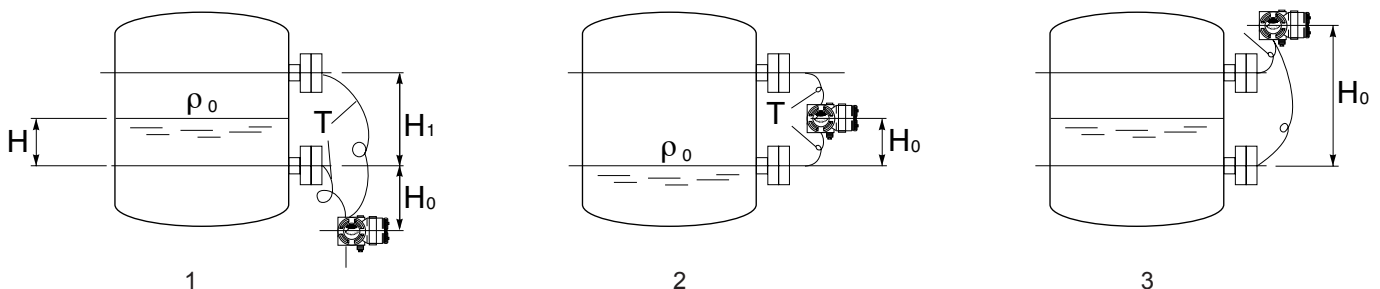

Caution on installation

- In order to prevent vibration of the transmitter body and capillary from interfering with output, the transmitter body should be installed at a vibration free place and the capillary should be fixed to a stable support.
- Avoid to locate capillaries (high and low pressure) in a place where ambient temperature and sunlight are very different. It can be influence the measurement. If it is not possible, please put a warm up system to maintain a constant temperature.
- Do not scratch or shock the seal diaphragm by hitting hard object against it, for example. It would damage definitely the transmitter
- Do not apply an excessive force to the screw of flange during connection (respect the tightening torque according to pipie standard).

Freeze protection.

If the fluide can freeze, the transmitter and the impulse pipe must be warmed up with steam or a heater.

Do not exceed the temperature limits (measuring cell: 120°C maxi and transmitter: 85°C).

Even when the installations shut down the heat must be maintained, if not the transmitter and impulse pipes must be drained to prevent freezing.

3.2.6 Remote seal type absolute and gauge transmitter (FKB and FKM)

Seal on mounting flange face

When mounting the flange on the high pressure side, a gasket should be inserted between the flange of the transmitter and the flange of the tank.

Be careful to a potential leak who can effect the measure.

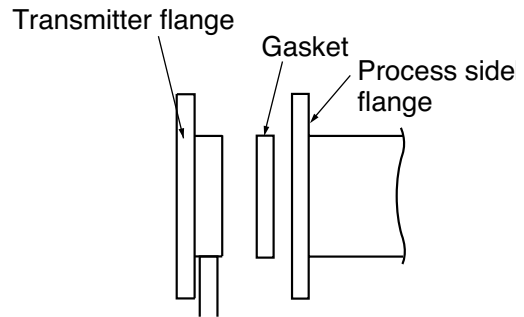

CAUTION

The seal must be chosen according type flange mounted on the transmitter. The internal diameter must be greater or equal to the diaphragm seal to not press it and effect the measure. Be careful to a potential leak who can effect the measure.

Standard dimension of the diaphragme seal are :

Flange size	Ø diaphragm seal (mm)
DN80 / 3"	SS : 73
	Special material : 89
DN100 / 4"	ISS : 96
	Special material : 89

For others flanges, consult Fuji Electric France.

Method for screwing the mounting flange

Tighten bolts of mounting flange and process flange in a diagonal order and about three cycles using the tightening torque corresponding to the screw used and according to the flange standard.

Recommandation for process connection

(1) Gas measurement

Locate the process tap above the pressure source

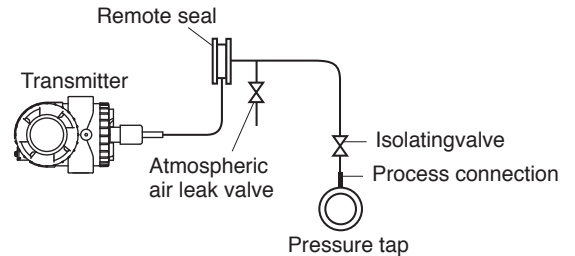

(2) liquid measurement

Locate the process connection below the pressure tap and the remote seal must be located below this one.

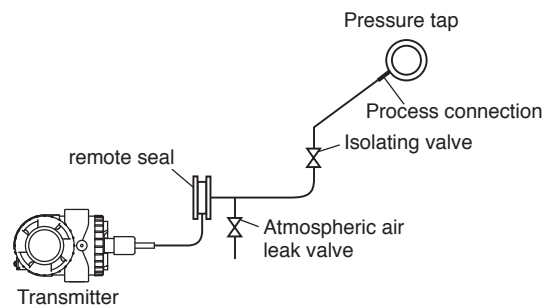

(3) Level measurement on open tank

H_1 must be more than half of the remote seal diaphragm diameter. Otherwise the measure will not be linear to the level as far as the diaphragm is not totally submerged.

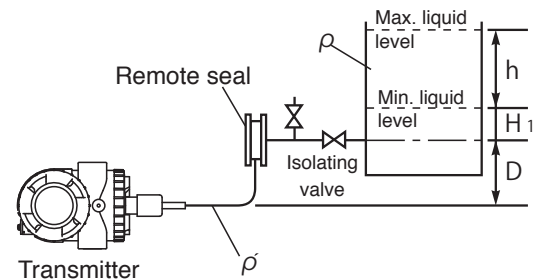

PROHIBITION

It is recommended to install the transmitter below the remote seal(s). It becomes necessary if process pressure is less than atmospheric pressure.

In order to prevent vibration of the transmitter body and capillary from interfering with output, the transmitter body should be installed at a vibration free place and the capillary should be fixed to a stable support.

 **DANGER**

In case of explosion proof, wiring shall be made in accordance with the relevant regulations to ensure the explosion proofing. Improper wiring can cause a risk of explosion, fire and other serious accidents.

 **CAUTION**

- Before making wiring work, be sure to turn OFF the main power to prevent electrical shocks.
- Use wiring materials of correct rating to prevent accidents.
- Use correct power source that meets the specifications to prevent fires.
- Field ground according the recommendations of electrical connections.
- After installing the transmitter, fcheck taht all covers are firmly closed to protect the transmitter against water ingress.

Cautions on wiring

- (1) Application of a voltage exceeding 60 V DC or 40 V AC (exceeding 33 V DC or 23 V AC when arrester equipped) between “+” and “-” terminals may result damage to the transmitter.
- (2) Use a shielded cable for the transmission line where possible.
- (3) Avoid installing signal and power cable in they same conduit or cable tray in order to avoid electromagnetic interferences..

4.1 Wiring procedure :

Sealing of conduit connection

To insure air tightness of the connection box, use sealing tape with metal pipe screw coupling or rubber gasket fastening gland

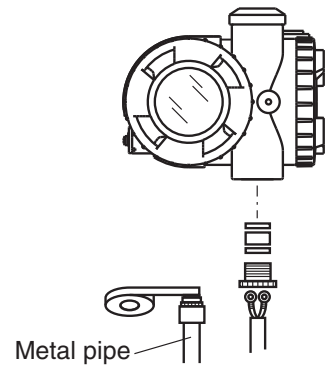

! INDICATION

1. If the conduit connection is located on the top side of the transmitter when using a protective tube for the wiring, then water may enter into the protective tube and have an adverse effect on the transmitter.
2. The thread of tube connection should match with the transmitter conduit thread.

Terminal block connection diagram

Tighten the terminal screws (M4x10) to a torque of approximately 1.5 Nm (15 kgf cm) <11ft-lb> so that the wires will not loosen.

After connection, fasten the cover until it does not turn.

Wiring diagram

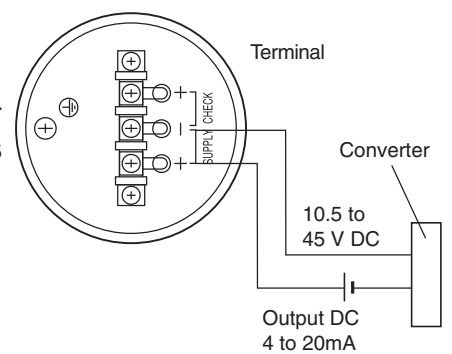
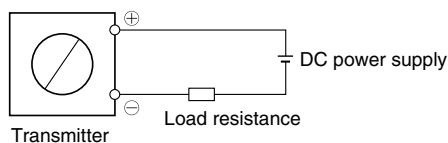

Voir "figure Fieldbus manuel" p3

When using an external indicator

For direct connection to an external field indicator, connect the "+" and "-" sides of the field indicator to CK+ and CK- of the transmitter as shown below.

Use an external field indicator with internal resistance of 12Ω or less.

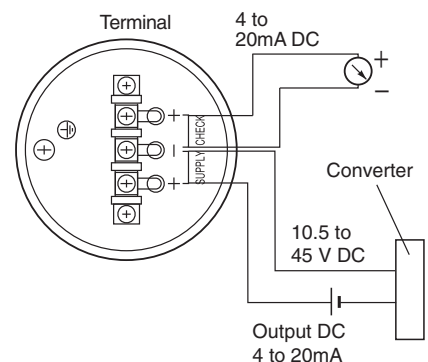

! INDICATION

Take care to respect the polarity when connecting the terminals

Caution on wiring

Two conduit connection are available and one is closed.

If the closed conduit connection must be used, please follow procedure below :

- (1) Remove the threaded plug of the top connection. Put a new seal (Teflon...) on the thread to ensure the sealing
- (2) Insert the cable through the free terminal connection and connect it.

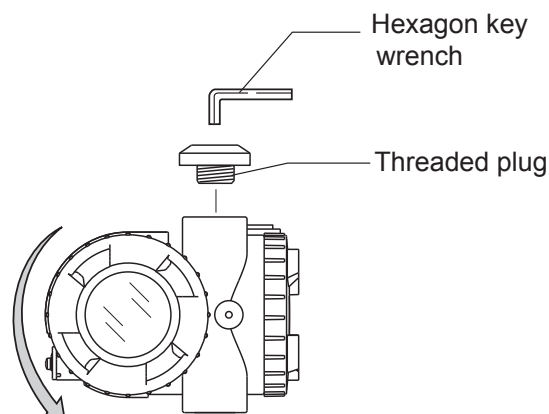

DANGER

- The unused terminal connection is of great importance to flameproof and water prevention.
- When performing an insulation check after wiring, use a megohmmeter of 250 V DC or less and avoid applying a high voltage. If an arrester is equipped, avoid the insulation resistance test and the dielectric strength measurement.

4.2 Power voltage and load resistance

Make sure the load resistance of the wiring connected to the loop is within the range shown below.

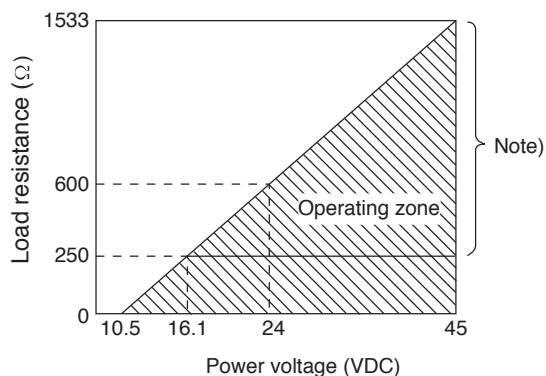

Note :

For Smart type, to communicate with the Hand Held Communicator (HHC) mini of 250Ω is required

4.3 Grounding

The transmitter must be grounded as below:

1- Standard location use

Grounding terminals are provided at two places (at the inside of terminal box and on the side of conduit connection).

By any of the methods given below, ground the transmitter in compliance with the relevant stipulation in the standard on explosion proof installation (for example, grounding resistance 100Ω or less by one of the methods given below).

Grounding of transmitter casing

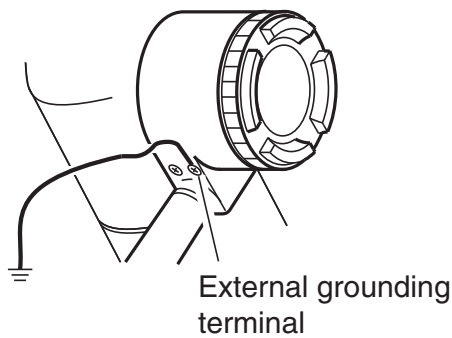

Grounding from ground terminal

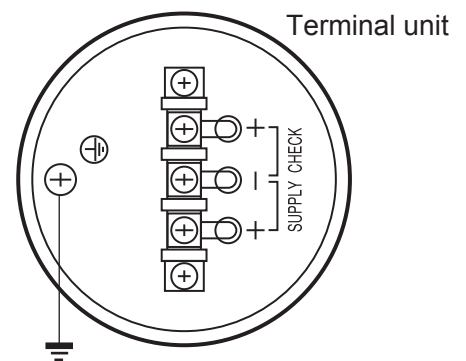

2- Hazardous location use

In case of intrinsically safe and flame proof installation, be sure to use the ground terminal for grounding.

5.1 Installation :

After installation (refer to chapter 3.1) and before start up of the transmitter, be sure to perform the following checks and procedures.

Preparation :

- (1) Check for liquid or gas leakage of the process connection by applying soapy water or similare.
- (2) Check of the electrical connection according to the "Terminal block connection diagram" shown in 4.1.
- (3) Vent the process covers of the transmitter.

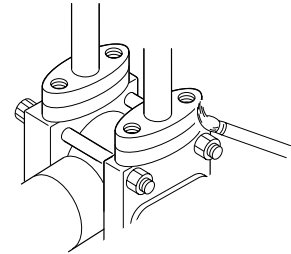

DANGER

Before starting up the transmitter in flameproof area, please read carefully the technical instruction note ATEX Ref.HDFCX-All V5 002.

The compatibility of process with the transmitter, has to be checked and ensured by skilled people from customer side.



CAUTION

When the plant requires chemical cleaning at the start up operation, be sure to close the isolating valves of the transmitter to avoid that cleaning liquid or particules are introduced to the transmitter wetted parts.

- (4) Perform zero point adjustment.

Zero point check

The zero point check or zero adjustment in flameproof area, is only possible by the screw on the electronics housing without opening the covers of this external housing.

- Power on the transmitter and wait for at least 10 minutes.
- Check the output signal of the transmitter by connecting a DC milliamperemeter across CK+ and CK- of the terminal block.
- After 10 sec or longer, adjust the transmitter output current at 4 mA (zero adjustment).

Zero adjustment :

The zero adjustment can be done :

- (1) With the external screw
Refer to chap.6.1 "Adjustment procedure using an external adjusting screw"
- (2) With LCD indicator
Refer to chap.6.2 "Adjustment procedure by local configurator unit with LCD display"
- (3) With Fuji Hand Held communicator
Refer to to chap.6.3 "Adjustment with hand held communicator"

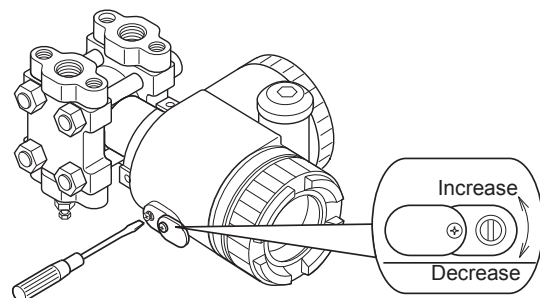

- Fine adjustment : turning slowly
(approximately 5sec per turn)
- Rough adjustment : turning quickly
(approximately 1sec per turn)



INDICATION

After adjustment, the transmitter must be kept energized for at least 10 seconds data recording completion into memory.



5.2 Operation

(1) Gauge (FKG) and absolute (FKA) pressure transmitter :

Open the valve slowly to apply a pressure.
When pressure is applied, the transmitter is set in the operating status.

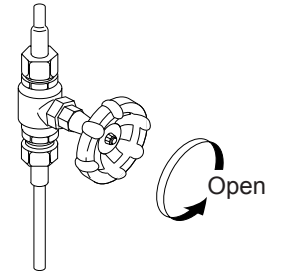

(2) Differential and flow pressure transmitter (FKC):

Set the operating status by manipulating the isolating valve.

Make sure the equalizing valve is open and make the zero adjustment (0%)

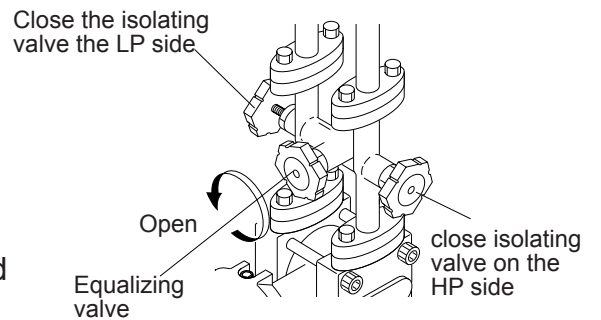

Open the isolating valve on the HP side slowly.

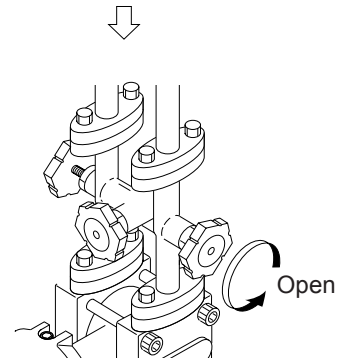

Close the equalizing valve.

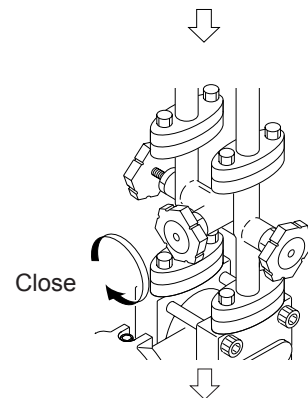

Open the isolating valve on the LP side slowly

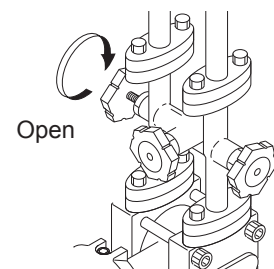

Check of operating status

Use a local indicator, receiving instrument or HHC to check the operating status.

5.3 Shutdown

Follow the procedures

(1) Absolute (FKA/FKH) and gauge (FKG/FKP) pressure transmitters :

Close the valve slowly to stop applying a pressure.
The transmitter is set in the measurement stop status.

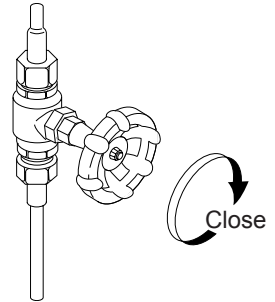

(2) Flow and differential pressure transmitter (FKC) :

Close the stop valve on the high pressure side (HP side) slowly.

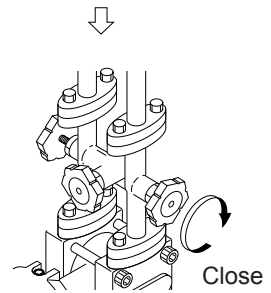

Open the equalizing valve.

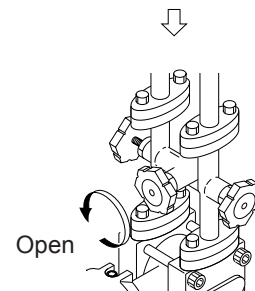

Close the stop valve on the low pressure side (LP side) slowly

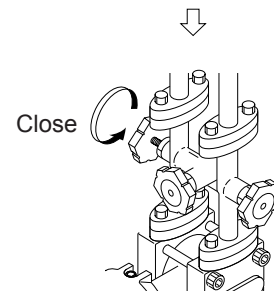

PROHIBITION Before a long shutdown, discharge the process fluid and drain completely from the transmitter. This is to protect the transmitter from freeze, corrosion, etc...

For adjusting the measuring range, carry out zero adjustment first, and span adjustment next using :

- External screw,
- LCD display with push buttons,
- Hand Held communicator,
- Hart Explorer software (if zero adjustment is performed after span adjustment, the 100% point may not be adjusted correctly).

Zero point is 4 mA output signal (LRV) and span is 20 mA output signal (URV). To adjust and specify these values, display the measured values (LRV, URV) with the portable communicator or the 3 keys on the transmitter's digital indicator.



DANGER

In the case of a flameproof transmitter, do not open the cover from amplifier case to make following adjustments with active DC power supply.

6.1 Adjustment procedure with the external screw

6.1-1 Zero adjustment

Zero point of the transmitter is adjustable by the external screw. Set the switch to ZERO position (see above figure).

Note :

If the transmitter has an indicator, remove it to access the setting switch.

(1) Select ZERO position

(2) Apply standard input pressure corresponding to Lower Range Value (LRV).

(3) Adjust zero point (4 mA) by turning the external screw

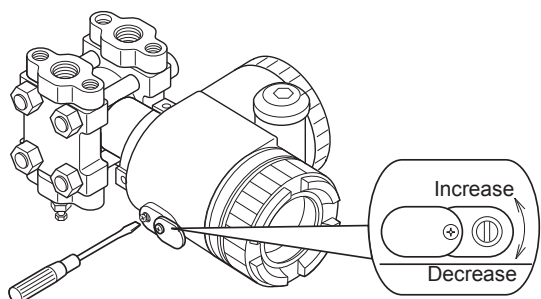

- Fine adjustment : turning slowly
(approximately 5sec per turn)
- Rough adjustment : turning quickly
(approximately 1sec per turn)

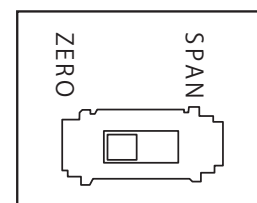
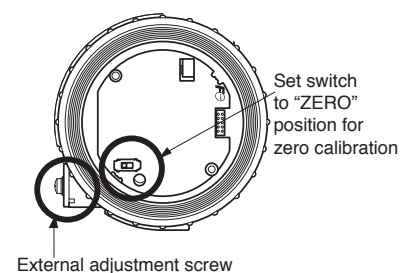

For zero suppression or elevation ranges, apply the specified pressure before adjust the 4/20 mA output signal using the external adjustment screw.

Note :

- 1) If the transmitter is locked, it can't be adjusted by the external adjustment screw.
- 2) When a digital indicator is attached to the transmitter, make sure that the LCD lamp "ZERO" is ON.



INDICATION

After adjustment, the transmitter must be kept energized for at least 10 seconds data recording completion into memory.



For zero suppression or elevation ranges, apply the specified LRV pressure in advance and adjust the output signal to 4.00 mA using the external adjustment screw.

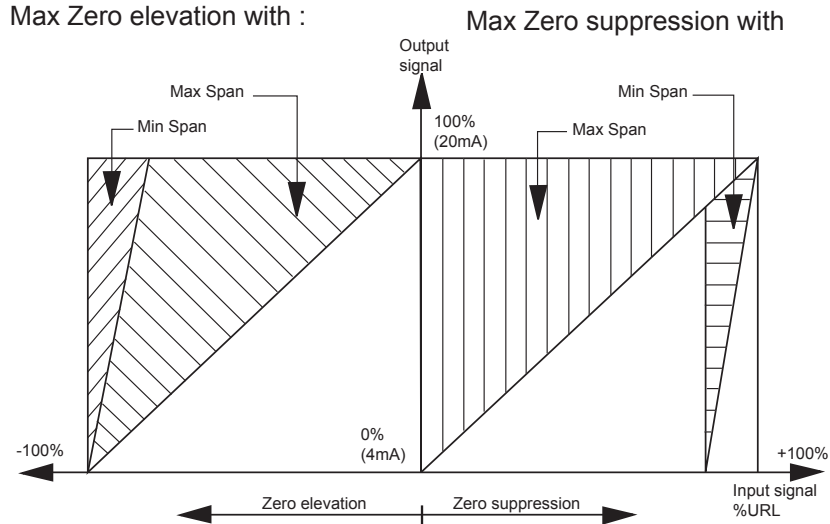

6.1-2 Span adjustment by the screw

The measuring range for each transmitter is determined according to its type. Span is changed by the outside screw with the mode setting switch in the housing set at span position. The figure shown below is an example of "Mode setting switch" is attached.

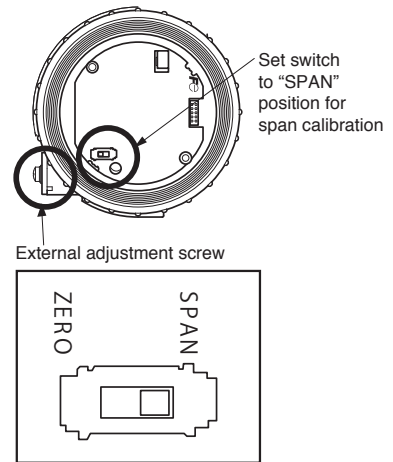

Note :
If the transmitter has an indicator, remove it to access the setting switch.

- (1) Set the mode setting switch to span position.
- (2) Apply standard input pressure corresponding to Upper Range Value (URV).
- (3) Adjust output to 20mA by turning the outside screw

! INDICATION After adjustment the span, reset the mode setting switch to Zero position

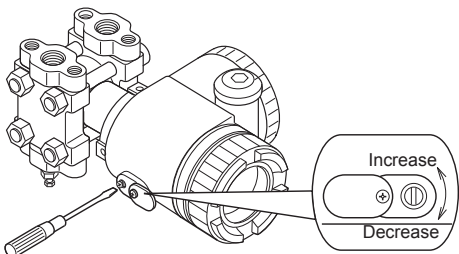

- Fine adjustment : turning slowly (approximately 5sec per turn)
- Rough adjustment : turning quickly (approximately 1sec per turn)

- Note :
- 1) If the transmitter is locked, it can't be adjusted by the external adjustment screw.
 - 2) When a digital indicator is attached to the transmitter, make sure that the LCD lamp "ZERO" is OFF during the span adjustment and ON when the span adjustment is finished.

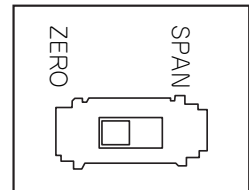

- (4) Then return to applying input pressure of zero again and make sure output is 4 mA.

! INDICATION After adjustment, the transmitter should be kept energized at about 10 seconds to write the adjustment results into memory.



6.2 Adjustment procedure by local configurator unit with LCD display

You can use various functions of the FCX-All V5 serie transmitters with 3 push button on the LCD display without using a Hande Held communicator.

Cautions for opération

DANGER To change the set value, check that the control loop of the host system (such as an instrumentation system) can be performed manually.

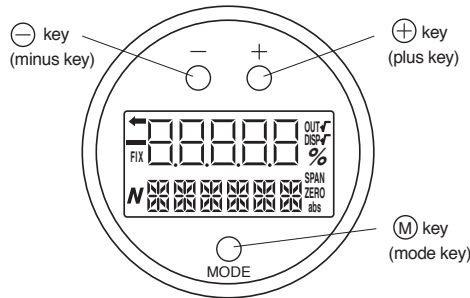

INDICATION Check on the LCD Display that "ZERO" is lighted. If not please see ... (paragraphe 6.2.1)

Mode switching

- To switch the normal mode to the setting mode:
Press the (M) key for two seconds or more.
- To switch the setting mode to the normal mode :

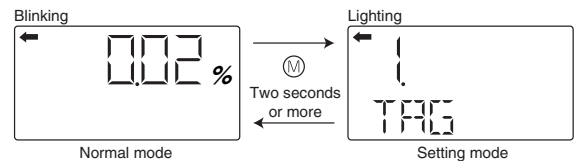

Press the (M) key for two seconds or more on the item name selection screen.

If no operation is performed for three minutes in the setting mode, the mode is automatically switched back to the normal mode.

Cautions for setting

For a transmitter with a LCD display and if the range is changed, please change the range of the LCD too.

- Setting error

If a setting error occurs, an error display shown on the lower right appears in the display.

Press the (M) key to return to the item name selection screen in the setting mode.

- Adjusting screw

Do not adjust the transmitter with the external screw if you adjust it with the 3 push button of LCD display.

- HHC transmission

In the setting mode, you can input commands during the item name selection screen.

6.2.1 Menu list

The following are the menu items. Adjust each setting as required.

Item (large classification)	Item name	Description	Page	
1	TAG No.	1. TAG	Display and setting of TAG No. (*1)	44
2	Model code	2. TYPE	Display and setting of type (*1)	45
3	Serial No.	3-1. SERIAL N	Display of serial No.	46
		3-2. VER	Display of transmitter software version	46
4	Engineering unit	4. UNIT	Display and change of engineering unit (*1)	47
5	Range limit	5. URL	Display of maximum measuring range	47
6	Measuring range	6-1. LRV	Change of LRV (lower range value of measuring range = 0% point) (*1)	48
		6-2. URV	Change of URV (upper range value of measuring range = 100% point) (*1)	49
7	Damping	7. DAMP	Change of damping time constant (*1)	50
8	Output mode	8-1. OUT Md	Change of output mode (*3) (*1)	51
		8-2. CUT Pt	Setting of low flow rate cut point (*3) (*1)	51
		8-3. CUT Md	Setting of low flow rate cut mode (*3) (*1)	52
9	Direction and value of burnout	9-1. BURNOT	Change of burnout direction (*1)	53
		9-2. OVER	Change of output value when burnout direction = OVERSCALE (*4) (*1)	53
		9-3. UNDER	Change of output value when burnout direction = UNDERSCALE (*5) (*1)	54
A	Zero/span calibration	A-1. ZERO	Zero calibration (*6) (*2)	55
		A-2. SPAN	Span calibration (*6) (*2)	56
B	Output circuit calibration	b-1. 4mAAdj	4 mA calibration (*8) (*2)	57
		b-2. 20mAAdj	20 mA calibration (*8) (*2)	57
		b-3. FIXcur	Constant current output (*8)	57
D	Self-diagnosis	d-1. AMPTMP	Display of internal temperature of transmitter	58
		d-2. ALMCHK	Display of self diagnosis.	58
F	Locking of adjustment functions	F. LOCK	Locking and unlocking of the adjusting screw and the adjustment function in the setting mode (*1)	59
G	LCD display range setting	G-1. LDV	LDV (Lower Display Value) setting (*1)	60
		G-2. UDV	UDV (Upper Display Value) setting (*1)	61
		G-3. DP	DP (number of digit after Decimal Point) setting (*1)	61
		G-4. LcdUnit	LcdUnit (LCD Unit Code) setting (*1)	62
		G-5. LcdOpt	LcdOpt (LCD Option) setting (*1)	62
I	Input-output range adjustment	I-1. LRVAdj	Zero adjustment by range (LRV) change (*6) (*2)	63
		I-2. URVAdj	Span adjustment by range (URV) change (*6) (*2)	64
J	Value and specification of saturation current	J-1. SAT LO	Change of saturation current value (lower limit) (*7) (*1)	65
		J-2. SAT HI	Change of saturation current value (upper limit) (*7) (*1)	65
		J-3. SPEC	Selection (Nomal specification/expanded specification) of specifications of burnout & saturation current (*1)	66
K	Protective function of set value	K. GUARD	Setting and cancellation of set value protection (write protect) (*9)	67
L	History information	L-1. HisZERO	Display of zero calibration data for users	68
		L-2. HisSPAN	Display of span calibration data for users	68
		L-3. HisCLEAR	Clearing of zero/span calibration data (*1)	68
		L-4. HisAMP	Display of min/max of amplifier temperature history information	69
		L-5. HisCELL	Display of min/max of cell temperature history information	69

*1: If the write protect is selected at "K. GUARD," the display for selecting whether the setting will be performed does not appear, but "GUARD" appears. You cannot change the value in this condition.

*2: If the adjustment function is locked at "F.Lock" or the write protect is selected at "K. GUARD," the item names is not displayed.

*3: Only differential pressure transmitters have this function. Other transmitters do not display the item name.

*4: This item is valid only if when the burnout direction = "OVERSCALE." If not, the item name is not displayed.

*5: This item is valid only if when the burnout direction = "UNDERSCALE." If not, the item name is not displayed.

*6: This item is valid only if polygonal line correction is invalid. If the polygonal line correction is valid or the equipment is defective, the item name is not displayed.

*7: You cannot change the value if the nomal specification is selected at "J-3: SPEC."

*8: In the multidrop mode, this item is invalid and the item name is not displayed.

*9: If the write protect function (with a password) is selected by the HHC, the item name is not displayed.

6.2.2 Switching menus

Setting mode with the \leftrightarrow button to select and display the different menus.

Press the M key for a few seconds to switch the normal mode to the setting mode.

Press the M key for a few seconds to switch the setting mode to the normal mode.

After selecting an item with the \ominus / \oplus keys, press the M key to access to the menu selected.

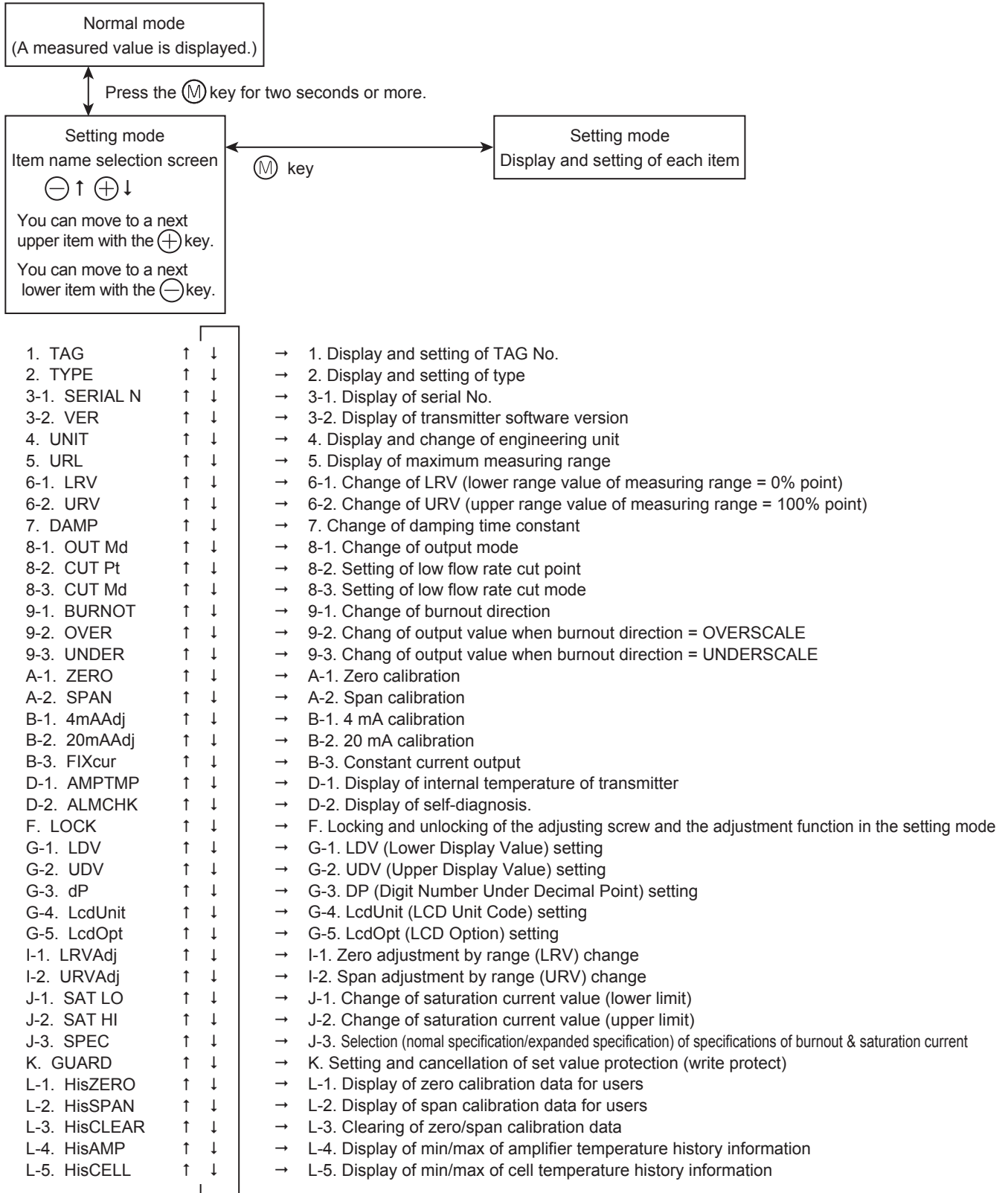

6.2.3 Operating procedure

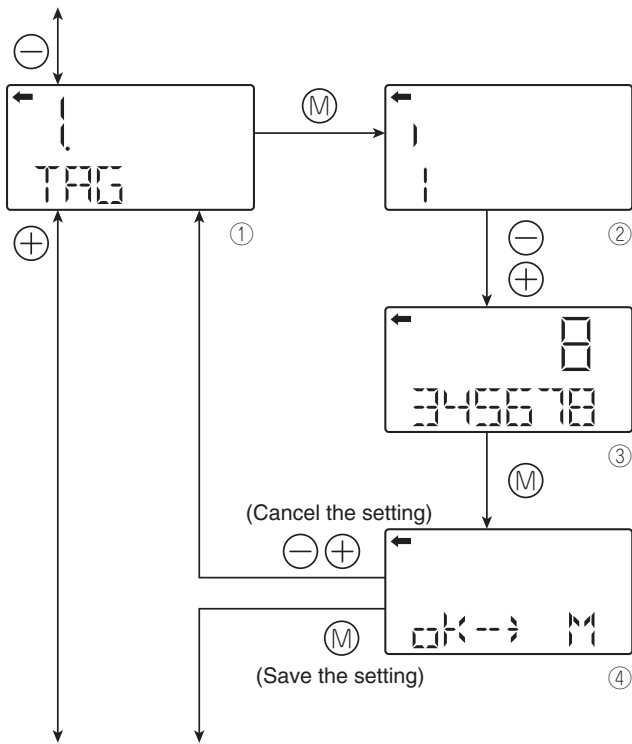

Menu 1 : TAG N° (1-TAG)

To set the TAG No. of the transmitter, use the procedures shown in the following diagram. TAG NO. can be inputted up to 26 character of alphanumeric codes.

- Press the **M** key on the screen ① to display the TAG No. setting (②).

- Input alphanumeric characters as required with the **-** and **+** keys on the screen ②.

Functions of the keys:

- key: To input characters at the cursor position

(0 to 9, space, A to Z, -)

- +** key: To move the cursor position to the next

(1 → 2 → 3 ... → 26 → 1)

Note)

Characters other than numerical characters, capital letters of the alphabet, space, and “-” are displayed as “*.”

Initial six characters are displayed. (The cursor position is displayed by a vertical bar.)

To display the seventh and following characters, scroll the characters to the left. (The cursor position (far right) is displayed as a number.)

The cursor position is 1 in the example ②. (Number 1 is input as the first character.)

The cursor position is 8 in the example ③. (Number 8 is input as the eighth character.)

If HART is selected, the initial eight characters are treated as TAG information.

- Select whether the TAG No. on the screen ④.

Press the **M** key to save the TAG No. setting.

Press the **-** or **+** key to cancel the setting.

* Description of the displays on the first line on the item name selection screen (①)

: Differential pressure transmitter

: Pressure (gauge pressure) transmitter

: Absolute pressure transmitter

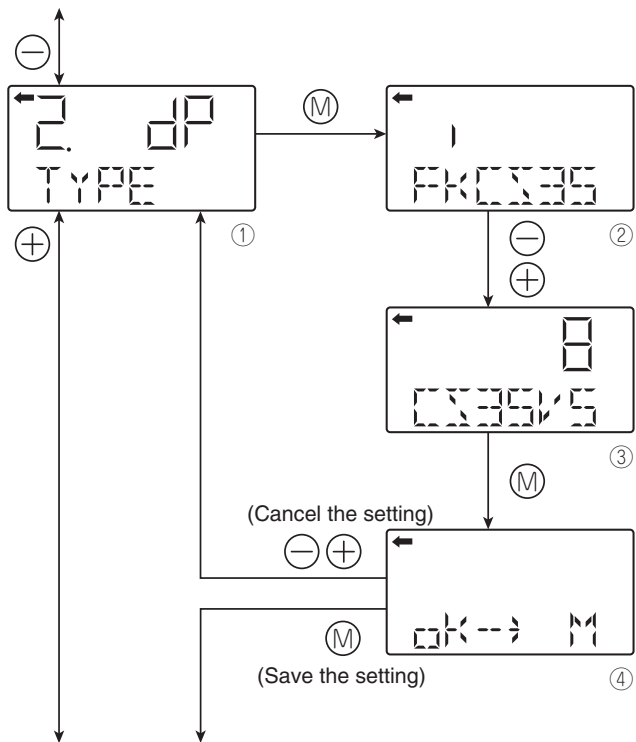

Menu 2 : Model code (TYPE)

Model code of field device is displayed and changed (example of differential pressure transmitter).

- Press the **M** key on the screen ① to display the model code setting screen ②.
- Input alphanumeric characters as required with the **-** and **+** keys on the screen ②.

Functions of the keys:

- ⊖ key: to input characters at the cursor position.
(0 to 9, space, A to Z, -)
- ⊕ key: to move the cursor position to the next.
(1 → 2 → 3 ... → 16 → 1)

Note)

Characters can be input up 24.

Characters other than numerical characters, capital letters of the alphabet, space, and “-” are displayed as “*.”

Initial six characters are displayed. (The cursor position is displayed by a vertical bar.)

To display the seventh and following characters, scroll the characters to the left. (The cursor position (far right) is displayed as a number.)

The cursor position is 2 in the example ②. (“K” is input as the second character.)

The cursor position is 8 in the example ③. (“5” is input as the eighth character.)

- Select whether the type setting is saved on the screen ④.

Press the **M** key to save the type setting.

Press the **-** or **+** key to cancel the setting.

- * Description of the displays on the first line on the item name selection screen (①)

dp : Differential pressure transmitter

G : Pressure (gauge pressure) transmitter

A : Absolute pressure transmitter

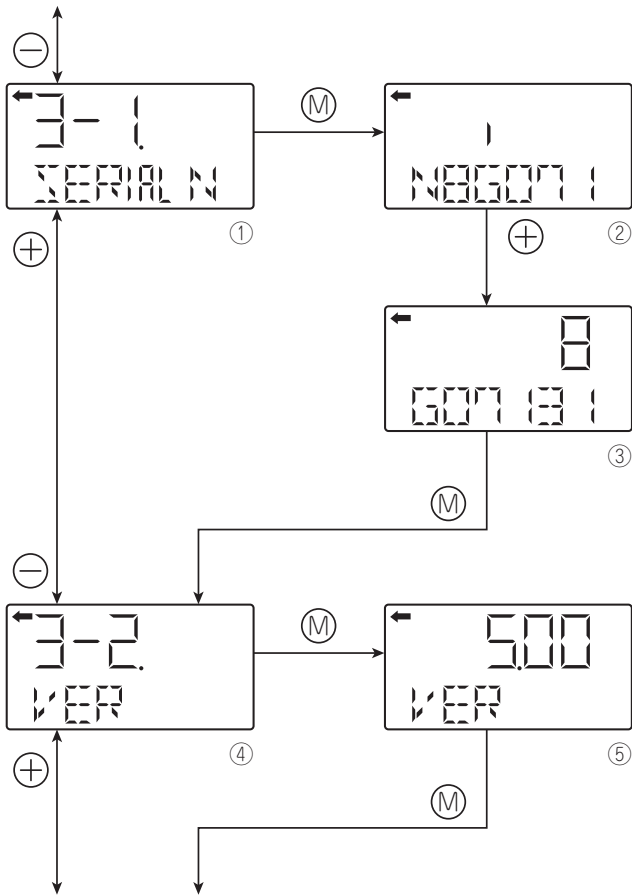

Menu 3 : Serial N° and Software version

SERIAL N°(8 letters) and transmitters software version are displayed.

3-1 SERIAL No : Display of SERIAL No.

- Press the **M** key on the screen ① to display the SERIAL N° (②)

Note)

Characters other than numerical characters, capital letters of the alphabet, space, and “-” are displayed as “*.”

Initial six characters are displayed. (The cursor position is displayed by a vertical bar.)

To display the seventh and following characters, scroll the characters to the left by pressing **+** key. (The cursor position (far right) is displayed as a number.)

3-2 VER : Display of transmitter software version

- To display the software version (⑤), press the **M** key on the screen ④.

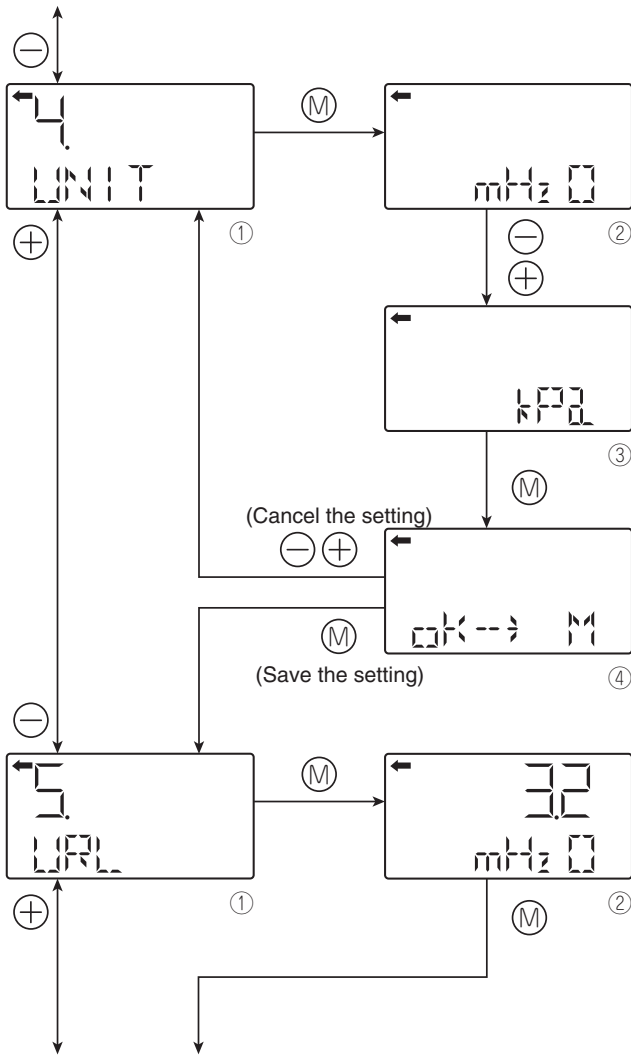

Menu 4 : Engineering unit

- To display the screen for changing the engineering unit (2), press the M key on the screen 1.
- Select an engineering unit with the ⊖ and ⊕ keys on the screen 2.

Available units for FCX-AIIV5

- mmH₂O
- cmH₂O
- mH₂O
- g/cm²
- kg/cm²
- Pa
- hPa
- kPa
- MPa
- mbar
- bar
- psi
- inH₂O
- ftH₂O
- mmAq
- cmAq
- mAq
- mmWC
- cmWC
- mWC
- mmHg
- cmHg
- mHg
- inHg
- < Torr >
- < atm >

Note: The mark < > is settable for absolute pressure transmitter only.

Menu 5 : Range limit

Indicates the maximum measuring range of this transmitter.

- To display the range limit value (2), press the M key on the screen 1.

Note)

If “setERROR” is displayed as a URL value, the unit is not supported.

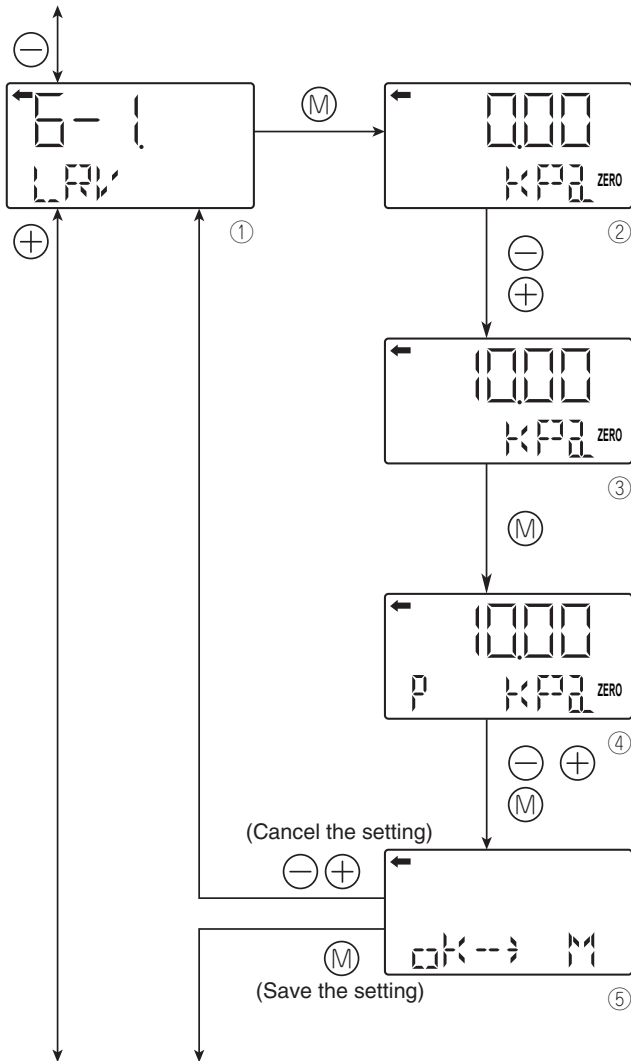

Menu 6 : Measuring range (LRV, URV)

LRV: Lower range value (0% point)

URV: Upper range value (100% point)

Selectable setting range

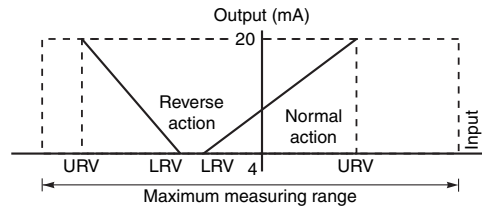

Note) If the set value of the LRV is outside the range, a setting error also occurs in the URV setting, and vice versa.

The maximum setting range is ± 99999 .

The URV may exceed the upper limit depending on the change of the UNIT. If that happens, change the URV first.

6-1 : Change of LRV (lower limit of the measuring range = 4 mA / 0% point)

- Press the M key on the screen ① to display the screen for setting the zero point range (0% point) (②).
- Input the numerical values with the \ominus and \oplus keys on the screen ②.

Functions of the keys:

\ominus key: To decrease the value.

\oplus key: To increase the value.

Range: $-99999 \leq \text{LRV} \leq 99999$

Note)

If "setERROR" is displayed as a LRV value, the range value is not supported.

- To set the decimal point position, press the M key on the screen ③. "P" is displayed at the left of the unit name (④) and you can set the decimal point position with the \ominus and \oplus keys.

\ominus key: To move the decimal point position to left

\oplus key: To move the decimal point position to right

- Select whether the LRV setting is saved on the screen ⑤.

Press the M key to save the zero point range setting.

Press the \ominus or \oplus key to cancel the setting.

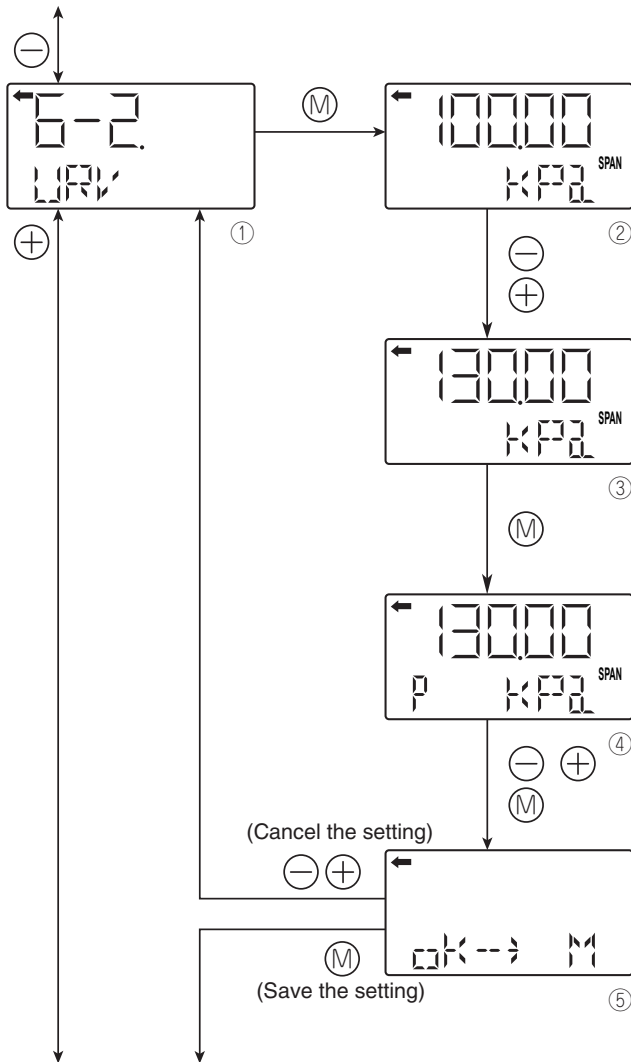

6-2 : Change of URV (upper limit of the measuring range = 20 mA / 100% point)

- Press the M key on the screen ① to display the screen for setting the 100% point (②).
- Input the numerical values with the \ominus and \oplus keys on the screen ②.

Functions of the keys:

\ominus key: To decrease the value.

\oplus key: To increase the value.

Range: $-99999 \leq \text{URV} \leq 99999$

Note)

If "UUUUU" is displayed as a URV value, the unit is not supported.

- To set the decimal point position, press the M key on the screen ③. "P" is displayed at the left of the unit name (④) and you can set the decimal point position with the \ominus and \oplus keys.

\ominus key: To move the decimal point position to left

\oplus key: To move the decimal point position to right

- Select whether the URV setting is saved on the screen ⑤.

Press the M key to save the 100% point setting.

Press the \ominus or \oplus key to cancel the setting.



The setting range of the transmitter is independent of the setting range of the indicator.

After changing the range in this menu, it is necessary to change the range in the LCD indicator (menu G).

Using an analog indicator and if the transmitter range is changed, replacement of the analog indicator is required.

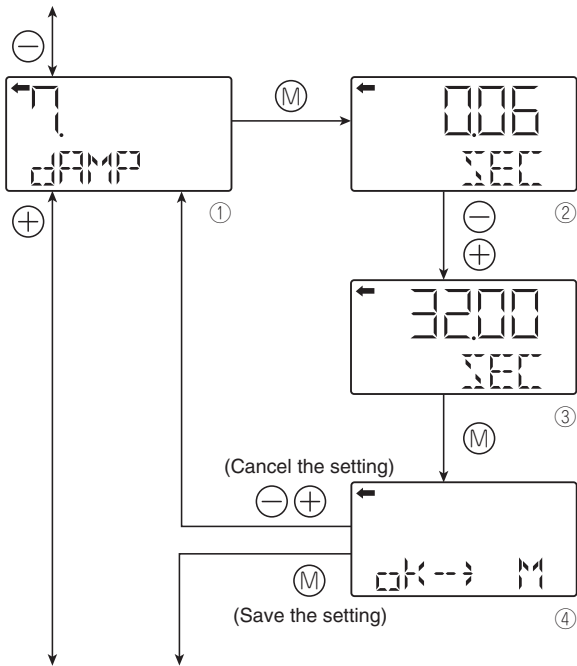

Menu 7 : Damping

In the case where the process input fluctuation or the vibration of the installation site is important, it is required to set appropriate damping time to avoid the output fluctuation.

- Press the **M** key on the screen ① to display the screen for changing the damping time constant (②).
- Input the damping time constant with the **-** and **+** keys on the screen ②. Press the **-** key to decrease the value and press the **+** key to increase the value.
Settable range: 0.06 to 32.0 sec
- Select whether the damping time constant setting is saved on the screen ④.
Press the **M** key to save the damping time constant setting.
Press the **-** or **+** key to cancel the setting

About the output fluctuation of the transmitter caused by vibration and damping

1) Magnitude of output fluctuation (oscillation) caused by vibration

If the transmitter is mounted to a place subject to severe vibration, output fluctuation (oscillation) may increase. Since the transmitter uses oil as internal pressure transmitting medium, if acceleration is caused by vibration, internal pressure is generated in accordance with the acceleration value, thus resulting in the output fluctuation. The magnitude of output oscillation may become the value shown below at the maximum.

Oscillation frequency: 10 to 150 Hz
Within $\pm 0.25\%$ of URL/(9.8m/s²)

2) Damping

The output fluctuation (oscillation) of the transmitter in an environment subject to vibration can be damped by setting appropriate damping time constant. The following table shows the effect of damping on the vibration of 10Hz where the output fluctuation becomes the maximum.

Guideline of the effect of damping on the output fluctuation (oscillation)

Damping set value [sec]	Damping of output oscillation	Remarks
1.2	1/3 or lower	
4.8	1/5 or lower	
19.2	1/10 or lower	

Note) In the oscillation range from 10 to 150Hz, the output fluctuation (oscillation) becomes the maximum at 10Hz, that is, the lowest frequency.

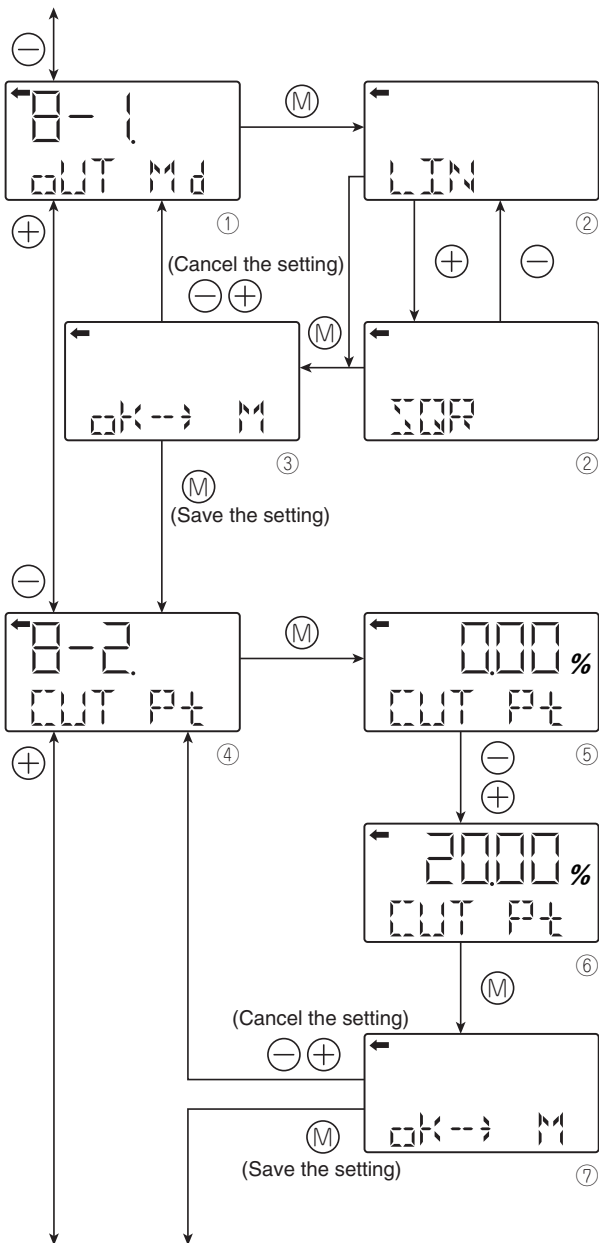

Menu 8 : Output mode

The output mode is used to select the proportional mode (proportional to input differential pressure) or square root extraction mode (proportional to flow rate) for the output signal (4 to 20 mA) of the differential pressure transmitter only.

In the square root extraction mode, you can set the cut point of low cut and the modes below the cut point.

8-1 oUT Md : Change of output mode

- Press the **M** key on the screen ① to display the screen for changing output mode (②).
- You can select the proportional or square root extraction mode on the screen ②. Select LIN (proportional mode) or SQR (square root extraction mode) with the **-** or **+** key and press the **M** key.
- Select whether the output mode setting is saved on the screen ③. Press the **M** key to save the output mode setting. Press the **-** or **+** key to cancel the setting.

8-2 CUT Pt : Low cut point setting

If you select the square root mode, you can set the low cut point.

Cut point is adjustable within the range of 0.00 to 20.00%. Note that if the cut point is set to a small value around 0%, even a minute differential pressure change causes a sudden output fluctuation. The cut point is used for improving the measurement in case of low flowrate.

- Press the **M** key on the screen ④ to display the screen for setting the low cut point (⑤).
- You can set and change the low cut point by inputting the numerical values with the **-** and **+** keys on the screen ⑤. Settable range: 0.00 to 20.0%
- Select whether the cut point setting is saved on the screen ⑦. Press the **M** key to save the cut point setting. Press the **-** or **+** key to cancel the setting.

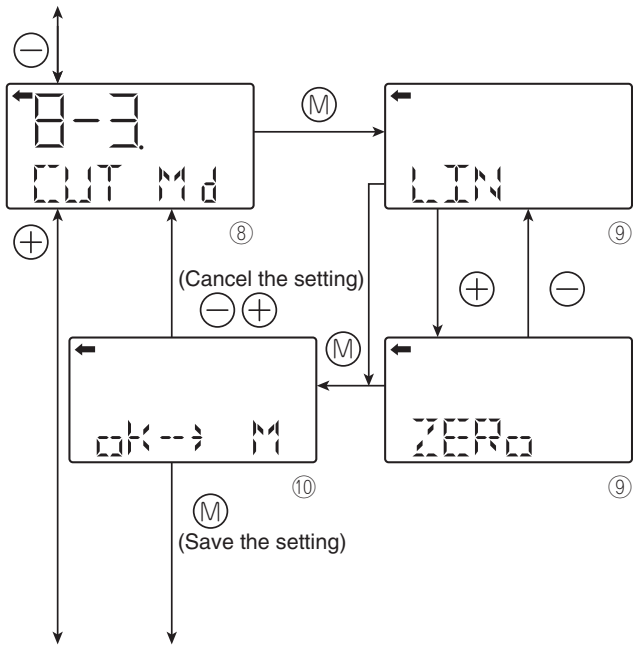

8-3 CUT Md : Low cut mode setting

There are two modes :

- Linear output between zero and the low cut point (fig A)
- Zero output until the low cut mode (fig B)

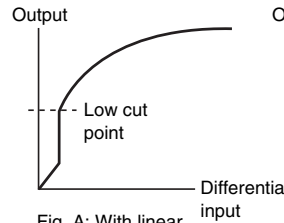

Fig. A: With linear output selected in low cut mode

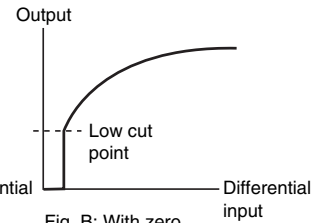
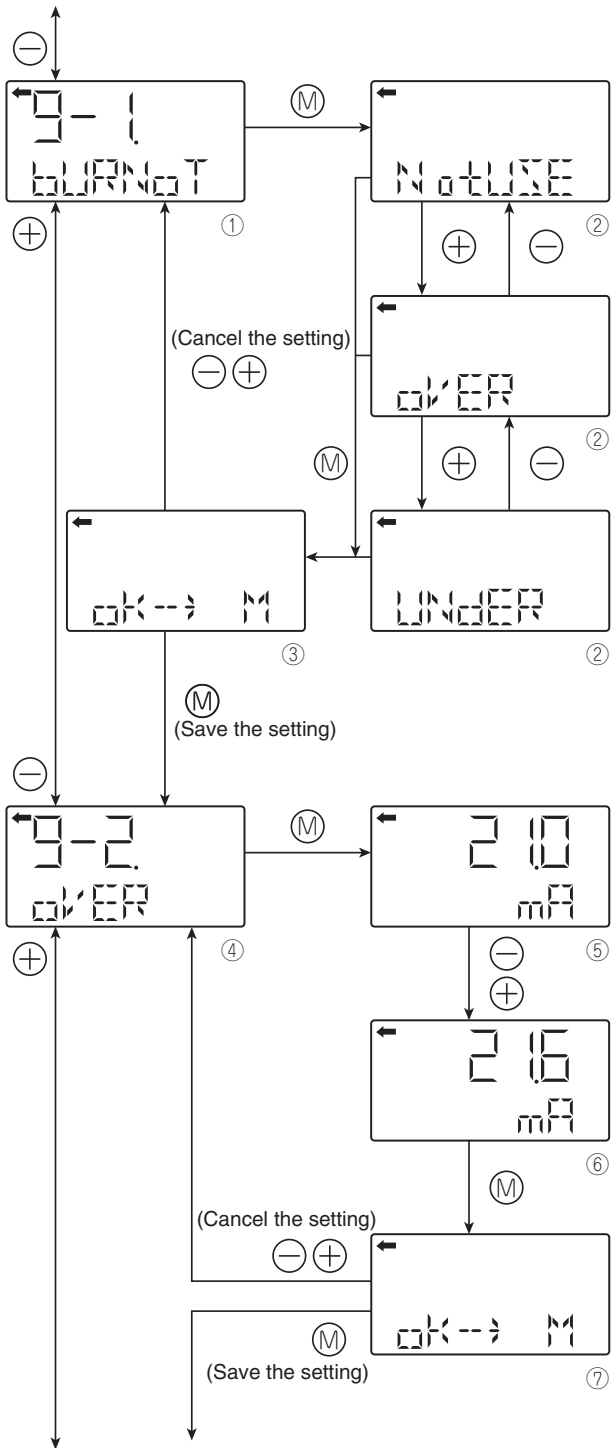

Fig. B: With zero output selected in low cut mode

- Press the **M** key on the screen **8** to display the screen for changing the outputs below the cut point (**9**).
- Select LIN (linear) or ZERO on the screen **9** with the **-** or **+** key and press the **M** key.
- Select whether the low cut point setting is saved on the screen **10**.
Press the **M** key to save the low cut point setting.
Press the **-** or **+** key to cancel the setting.



See the next page for the procedure when UNdER is selected.

Menu 9 : Burnout direction

Used for selecting output at occurrence of a fault in the detecting unit.

9-1 bURNOT : Change of burnout

NotUse → Output hold

OVER → OVERSCALE

UNDER → UNDERSCALE

- For NAMUR specification, press the M key on the screen ① to display the screen for changing the burnout (②).
- Select NotUse, OVER or UNDER on the screen (2) with the ⊖ or ⊕ key and press the M key.
- Select whether the burnout setting is saved on the screen ③.

Press the M key to save the burnout setting.

Press the ⊖ or ⊕ key to cancel the setting.

9-2 OVER : Change of burnout current when OVER (OVERSCALE)

This display appears if you select “OVER” for the burnout.

- Press the M key on the screen ④ to display the screen for changing the burnout current for OVERSCALE (⑤).
- You can change the burnout current with the ⊖ and ⊕ keys on the screen ⑤.

Settable range:

For NAMUR specification, 21.6, 21.8, 22.0, 22.2, 22.4, 22.5 can be selected

Note)

You can change the saturation current value (upper limit) setting at “J: Value and specification of saturation current.”

- Select whether the burnout current setting is saved on the screen ⑦.

Press the M key to save the burnout current setting for OVERSCALE.

Press the ⊖ or ⊕ key to cancel the setting.

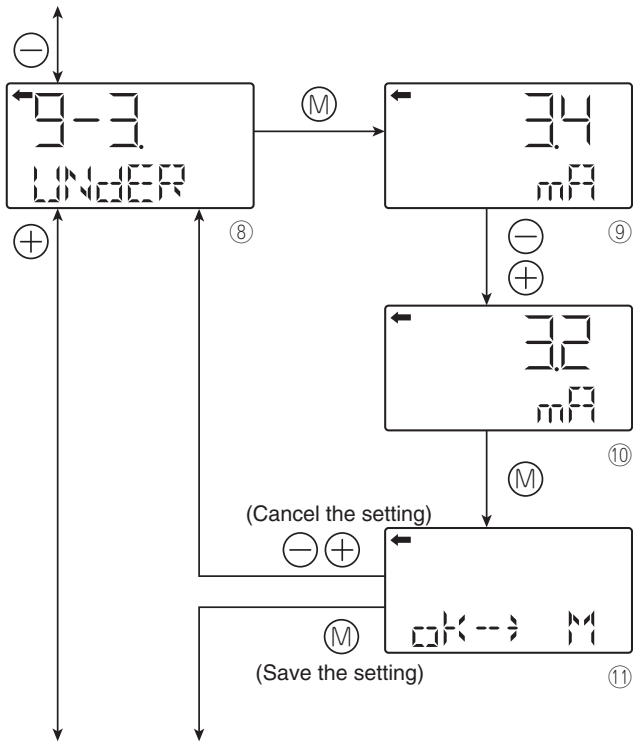

9-3 UNDER : Change of burnout current when UNDER (UNDERSCALE) is selected.

This display appears if you select “UNDER” for the burnout direction.

- Press the **M** key on the screen **8** to display the screen for changing the burnout current for UNDERSCALE (**9**).

- You can change the burnout current with the **⊖** and **⊕** keys on the screen **9**.

Settable range:

For NAMUR specification : 3.4 mA => Burnout (UNDER) =< 3.6 mA

- Select whether the burnout current setting is saved on the screen **11**.

Press the **M** key to save the burnout current setting for UNDERSCALE.

Press the **⊖** or **⊕** key to cancel the setting.

Note)

You can change the saturation current value (lower and upper limits) setting in “J. Value and specification of saturation current.”

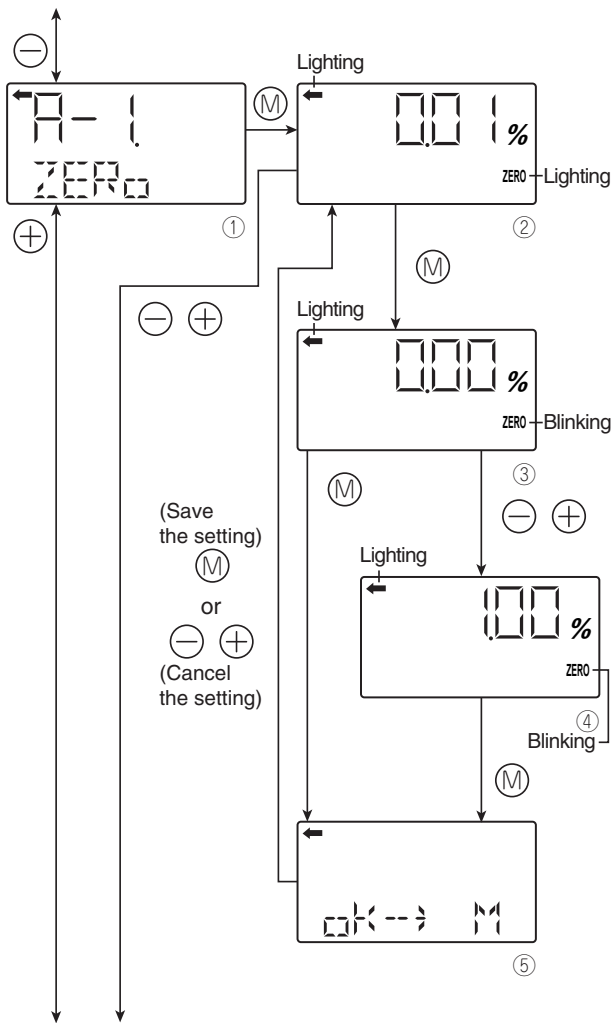

Menu A : Zero/span calibration

This menu gives the possibility to calibrate Zero (LRV) and span (URV) of the transmitter.

The ranging of the transmitter needs to be done in the "Range" menu 6. Please use menu A "CALIBRATE" only when the LRV and URV are fixed in the "RANGE" menu.

It is absolutely necessary to the zero or LRV point as well as the span or URV point when making a calibration.

! INDICATION

1. After performing a zero calibration, perform a span calibration.
2. If you input the value that exceeds the adjustable range, the setting will not be changed even after the setting is saved.
Adjustable range
Zero calibration: within ±40% of the max span
Span calibration: within ±20% of the set span

A-1 Zero (LRV) calibration

- Press the **M** key on the screen ① to select the zero calibration mode.
The measured value and unit on the screen ② are the same as those in the normal mode and "←" and "ZERO" light up.
- Apply the actual input pressure on the screen ②. After checking the measured value, press the **M** key.
- "ZERO" blinks on the screen ③. Press the **M** key on the screen ③ to perform a zero calibration at the input pressure at the time.
- To perform a zero calibration at a point other than 0%, input an appropriate set value (%) (④) with the **-** and **+** keys, and press the **M** key.
- Select whether the zero calibration value setting is saved on the screen ⑤.
Press the **M** key to save the zero calibration value setting and return to the screen ②.
Press the **-** or **+** key to cancel the setting and return to the screen ②.
- Check that the zero calibration was performed as intended.
Press the **M** key to perform a zero calibration again.
Press the **-** or **+** key to move to the next screen for item name selection.

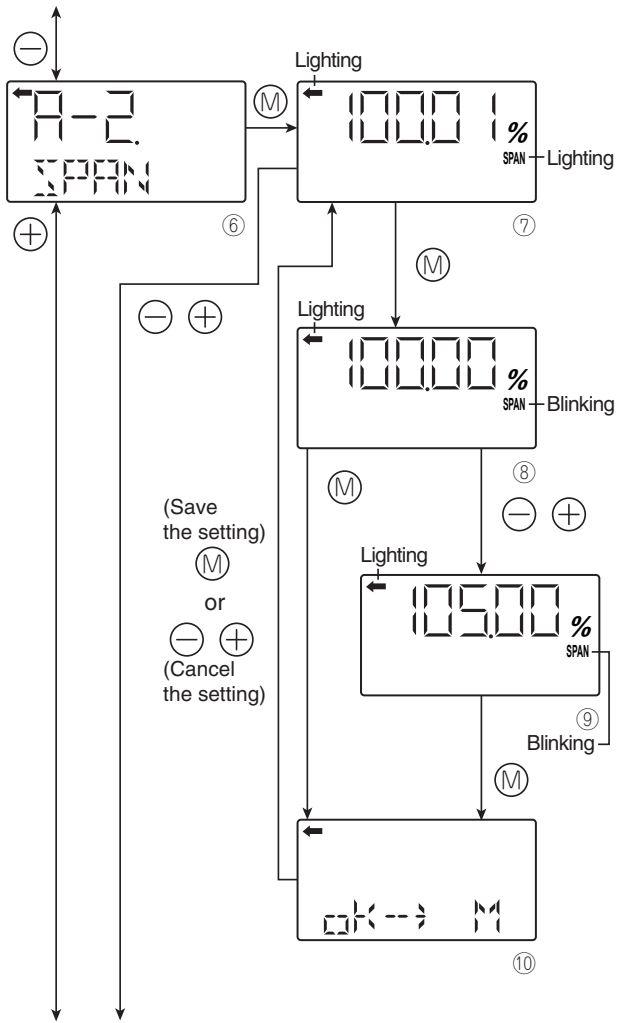

A-2 Span (URV) calibration

- Press the **M** key on the screen ⑥ to select the span calibration mode.

The measured value and unit on the screen ⑦ are the same as those in the normal mode and "←" and "SPAN" light up.

- Apply the actual input pressure on the screen ⑦. After checking the measured value, press the **M** key.
- "SPAN" blinks on the screen ⑧. Press the **M** key on the screen ⑧ to perform a span calibration at the input pressure at the time.

To perform a span calibration at a point other than 100%, input an appropriate set value (%) ⑨ with the ⊖ and ⊕ keys, and press the **M** key.

$$PL = \text{Upper limit of adjustment point} \times 100$$

Setting range

- Select whether the span calibration value setting is saved on the screen ⑩. Press the **M** key to save the span calibration value setting and return to the screen ⑦. Press the ⊖ or ⊕ key to cancel the setting and return to the screen ⑦.
- Check that the span calibration was performed as intended. Press the **M** key to perform a span calibration again. Press the ⊖ or ⊕ key to move to the next screen for item name selection.

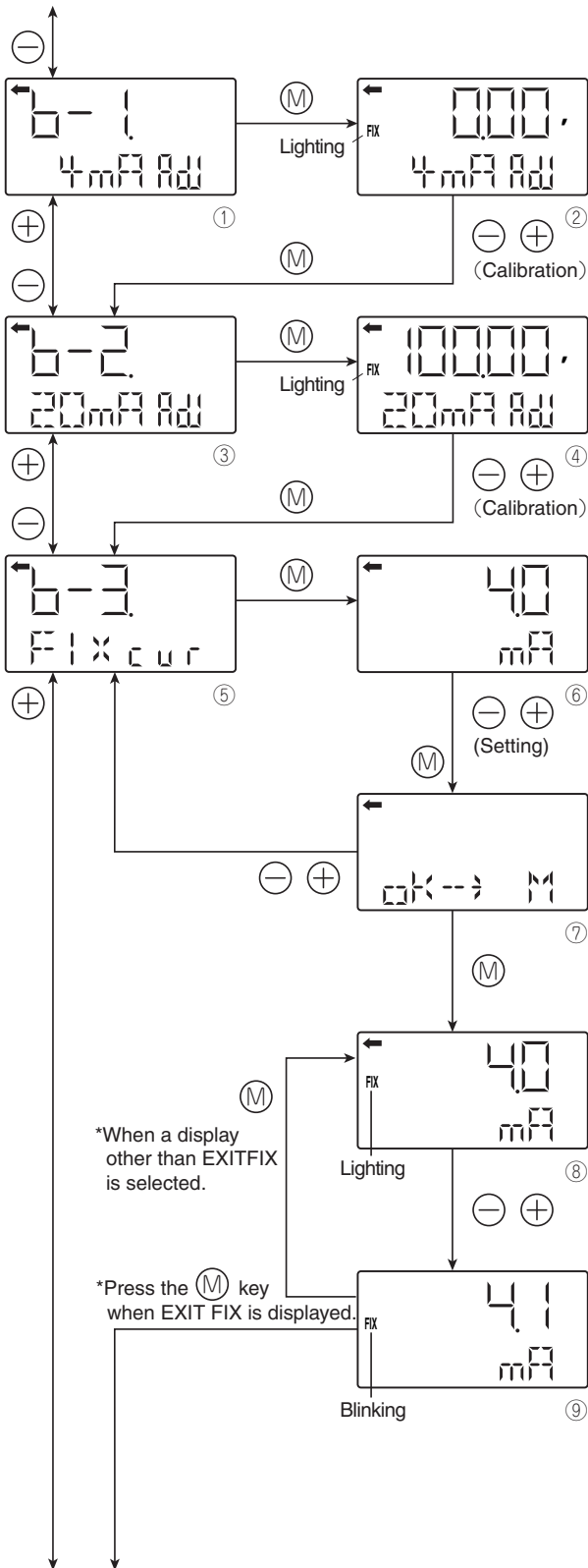

Menu B : Calibration of output circuit (D/A)

The transmitter has a numerical electronic. The cell signals are processed by a microprocessor and sent to a digital/analog D/A converter to convert the signal in 4-20 mA.

This menu allows to calibrate the D/A converter. It is necessary to connect a milliamperemeter (accuracy ± 1 micro A) to check the output signal.

This menu allows too to check, with a 4-20 mA signal, the measuring loop.

The output circuit (D/A) should be calibrated by the following procedure when necessary.

Make transmitter connection according to "Calibration" in Appendix A2, and calibrate the output circuit using the following procedure.

b-1 4mA Adj : 4 mA adjustment

- Press the (M) key on the screen ① to display the screen for calibrating current mode 4 mA (②).
- Perform a calibration for 4 mA on the screen ② with the \ominus and \oplus keys.
- After the calibration, press the (M) key to move to the screen for calibration of 20 mA.

b-2 20mA Adj : 20 mA adjustment

- Press the (M) key on the screen ③ to display the screen for calibrating current mode 20 mA (④).
- Perform a calibration of 20 mA on the screen ④ with the \ominus and \oplus keys.
- After the calibration, press the (M) key to move to the constant current output screen.

b-3 FIXcur : Constant current output

- Press the (M) key on the screen ⑤ to display the screen for performing a constant current output (⑥).
- Input a current to be output on the screen ⑥ with the \ominus and \oplus keys.
Output value range
3.2 mA \leftrightarrow 21.6 mA \leftrightarrow EXITFIX (cancelation) \leftrightarrow 3.2 mA
- Press the (M) key on the screen ⑦ to confirm current value and the screen ⑧ appears.
Press the \ominus or \oplus key to cancel the input and return to the screen ⑤.
- Press the \ominus or \oplus key on the screen ⑧. FIX blinks and you can reset the constant current output value (⑨). Input a set value with the \ominus and \oplus keys, press the (M) key to return to the screen ⑧, and output the reset current.
- Select EXITFIX on the screen ⑨ and press the (M) key to stop the constant current output and move to the item name selection screen.

Note)

To exit of the constant current, please continue to scroll the value until EXITFIX.

If nothing is input for three minutes in the status of the constant current output, the screen returns to the normal mode with the constant current output kept. You can confirm it by the lighted FIX. Select the setting mode again. Select "FIX cur" on the display ⑨ in the items of "6-3. FIX cur" and press the (M) key to terminate the constant current output.

Menu D : Self-diagnosis

Self-diagnosis display shows the internal temperature of the transmitter and the failure description.

d-1 AMPTMP : Internal temperature of the transmitter

- Press the M key on the screen ① to display the screen of internal temperature of the transmitter (②). When a temperature alarm is issued, "TEMP" is changed to "ALM."

(This corresponds to "AMP TMP" of "Error display of self-diagnosis" in the following table.)

If the temperature cannot be measured due to defective internal data, "IMPOSS" is displayed.

(This corresponds to any of "RAM ER", "PAR ER" or "AMP EP" of "Error display of self-diagnosis" in the following table.)

d-2 ALMCHK : Display of self-diagnosis results

- Press the M key on the screen ③ to show the self-diagnosis results (④). Press the \ominus and \oplus keys to display errors sequentially.

See the following table "Contents of message" for the errors of the transmitter.

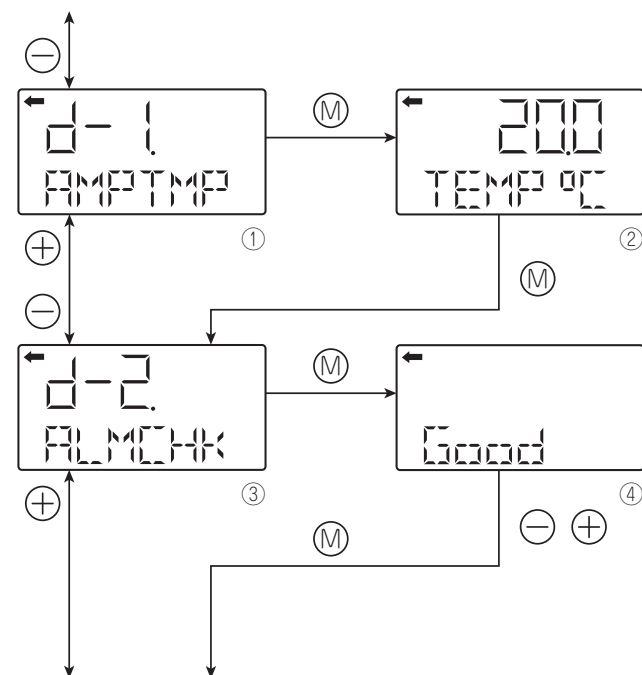

[Contents of message]

As a result of self-diagnosis, the message below is appeared on the LCD display, when there are trouble in the transmitter. For each error, its cause and remedy are suggested.

Error display of self-diagnosis	Display in normal mode	Cause	Remedy
C1 ERR ~ C9 ERR	FL-1	Error of detecting unit	Check the wiring between the detecting unit and transmitter. If the error is not recovered, replace the detecting unit.
RAM ER	FL-1	Calculation parameter (RAM) error	Replacement of amplifier
PAR ER		Error of magnitude relation of temperature data	
AMP EP	FL-2	EEPROM error on amplifier side	Replacement of amplifier
CEL EP	FL-3	EEPROM error on cell side	Replacement of detecting unit
AMP TMP	T. ALm	Amplifier temperature error	Transmitter temperature is normalized.
CEL TMP	T. ALm	Cell temperature error	
	OVER	Input pressure: J-2, saturation current (Hi) or higher	Correction of input pressure
	UNDER	Input pressure: J-1, saturation current (Lo) or lower	Correction of input pressure

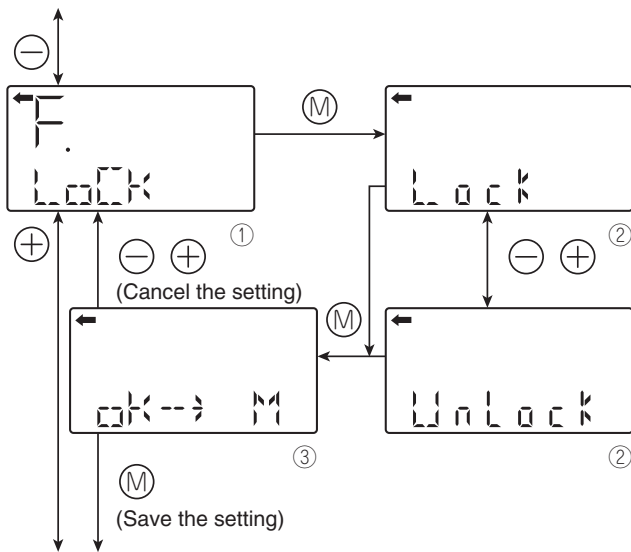

Menu F : Lock of adjustment functions

You can lock/unlock the adjustment function of the local configurator unit as follows.

! INDICATION

When the adjustment functions are locked, the external adjusting screw is also locked.

- Press the \oplus key on the screen ① to display the lock selection screen of adjusting functions (②).
- Select the locking/unlocking of the adjustment functions on the screen ② with the \ominus and \oplus keys. Select the locking to lock the adjustment functions of the local configurator unit with LCD display. Select the UnLock to cancel the lock of the adjustment functions of the local configurator unit with LCD display.
- Select whether the locking/unlocking of the adjustment functions are saved on the screen ③. After selecting the locking/unlocking, press the \oplus key to save the setting. Press the \ominus or \oplus key to cancel the setting and return to the screen ①.

List of adjustment functions locked/unlocked

A. Zero/span calibration	A-1. ZERO
	A-2. SPAN
B Output circuit calibration	b-1. 4mA Adj
	b-2. 20mA Adj
I. Input/Output range adjustment	I-1. LRV Adj
	I-2. URV Adj

Menu G : Setting of LCD display

The LCD display is independent of the transmitter setting. So the LDC display must be set.

In this menu, it is possible to change the range (0%-100%), the unit and the value type displayed.

G-1 LDV : LCD setting for the 0% (4mA)

- Press the M key on the screen ① to display the screen for setting the indicated value corresponding to 0% (②).
- Input the indicated value corresponding to 0% of the actual scale on the screen ② with the \ominus and \oplus keys. Functions of the keys:
 - \ominus key: To decrease the value
 - \oplus key: To increase the value
- To set the decimal point position, press the M key on the screen ②. "P" is displayed at the right of the unit name (③) and you can set the decimal point position with the \ominus and \oplus keys.
 - \ominus key: To move the decimal point position to left
 - \oplus key: To move the decimal point position to right
- Select whether the indicated value setting of 0% is saved on the screen ④. Press the M key to save the indicated value setting. Press the \ominus or \oplus key to cancel the setting.

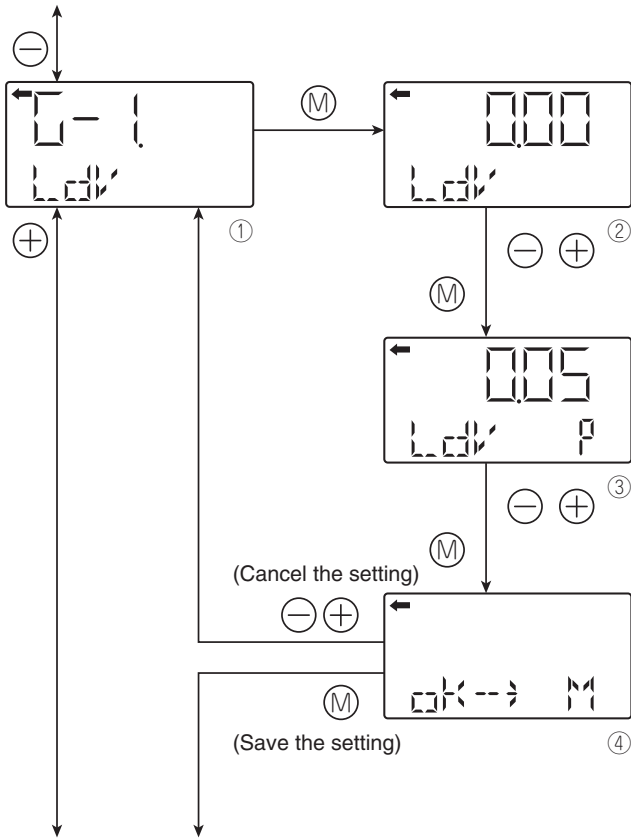

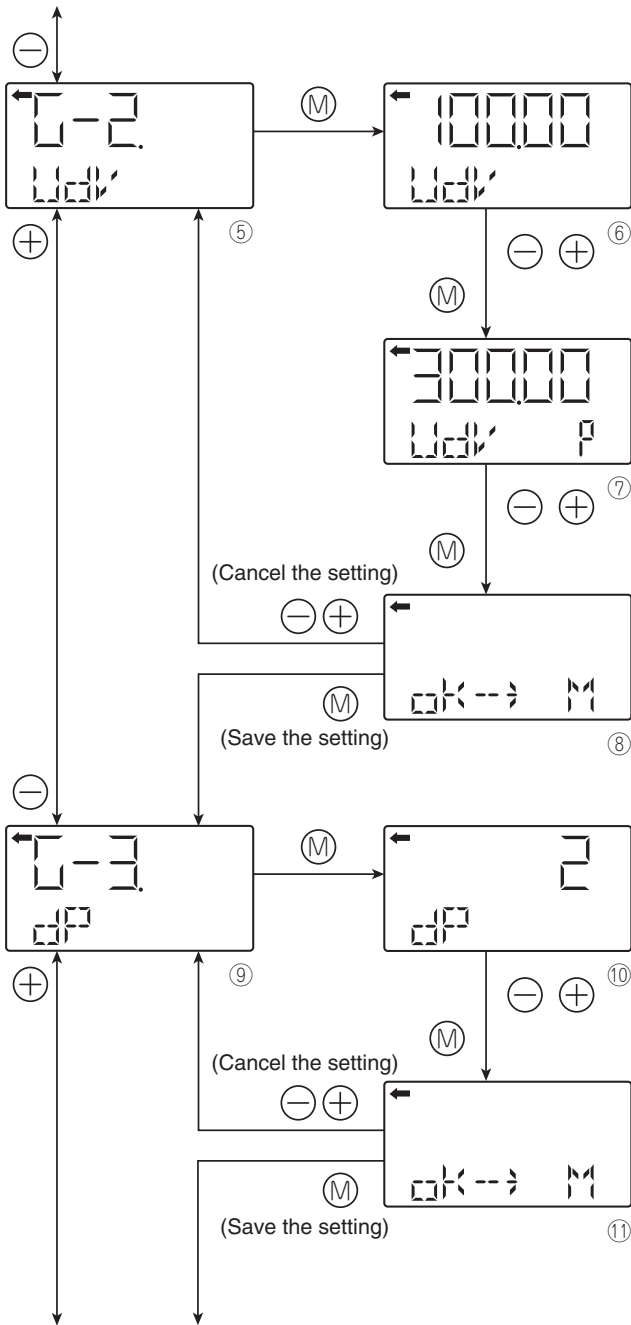

G-2 UDV : LCD setting for the 100% (20mA)

- Press the M key on the screen ⑤ to display the screen for setting the indicated value corresponding to 100% (⑥).
- Input the indicated value corresponding to 100% of the actual scale on the screen ⑥ with the \ominus and \oplus keys.
- Functions of the keys:
 - \ominus key: To decrease the value
 - \oplus key: To increase the value
- To set the decimal point position, press the M key on the screen ⑥. "P" is displayed at the right of the unit name (⑦) and you can set the decimal point position with the \ominus and \oplus keys.
 - \ominus key: To move the decimal point position to left
 - \oplus key: To move the decimal point position to right
- Select whether the indicated value setting of 100% is saved on the screen ⑧.
 - Press the M key to save the indicated value setting.
 - Press the \ominus or \oplus key to cancel the setting.

Note : The following scale can be set :

-99999 =< LDV (without decimal point) =< 99999
and
-20000 =< UDV-LDV =< 2000

G-3 DP : Decimal point setting

Set the number of digits after decimal point for the LCD indicated value.

- Press the M key on the screen ⑨ to display the screen for setting the DP (⑩).
- Input the DP on the screen (10) with the \ominus and \oplus keys.

Setting range:

$$0 \leq \text{DP} \leq 4$$

	Display range
DP=0	See note below
DP=1	-9999.9 ~ 9999.9
DP=2	-999.99 ~ 999.99
DP=3	-99.999 ~ 99.999
DP=4	-9.9999 ~ 9.9999

- Select whether the DP setting is saved on the screen ⑪.
 - Press the M key to save the DP setting.
 - Press the \ominus or \oplus key to cancel the setting.

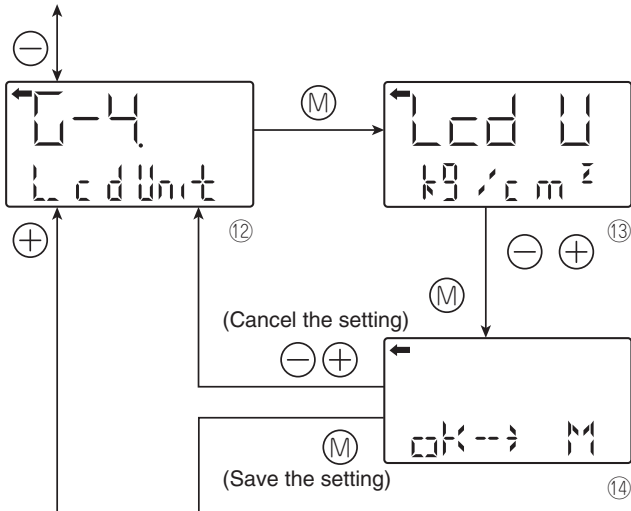

G-4 LcdUnit : Setting of the LCD value displayed

- Press the **M** key on the screen ⑫ to display the screen for setting the unit (⑬).
- Input the unit on the screen ⑬ with the **-** and **+** keys.
- Select whether the unit setting is saved on the screen ⑭.
- Press the **M** key to save the unit setting.
- Press the **-** or **+** key to cancel the setting.

Available unit for FCX-All

(a)	(b)	(c)
%(LIN)	mm	%(SQR)
NONE(LIN)	cm	NONE(SQR)
MPa	m	Nm ³ /s
kPa	in	Nm ³ /min
hPa	ft	Nm ³ /h
Pa		Nm ³ /d
bar		m ³ /s
mbar		m ³ /min
kg/cm ²		m ³ /h
g/cm ²		m ³ /d
mmH ₂ O		NI/s
cmH ₂ O		NI/min
mH ₂ O		NI/h
inH ₂ O		NI/d
ftH ₂ O		l/s
mmAq		l/min
cmAq		l/h
mAq		l/d
mmWC		gal/s
cmWC		gal/min
mWC		gal/h
mmHg		gal/d
cmHg		ft ³ /s
mHg		ft ³ /min
inHg		ft ³ /h
PSI		ft ³ /d
<atm>		bb/s
<Torr>		bb/min
		bb/h
		bb/d
		kg/s
		kg/min
		kg/h
		kg/d
		t/s
		t/min
		t/h
		t/d

The units in parentheses < > are displayed only when the absolute pressure transmitter is used.

The flow units in the column (c) can be set only for the group of differential pressure transmitters.

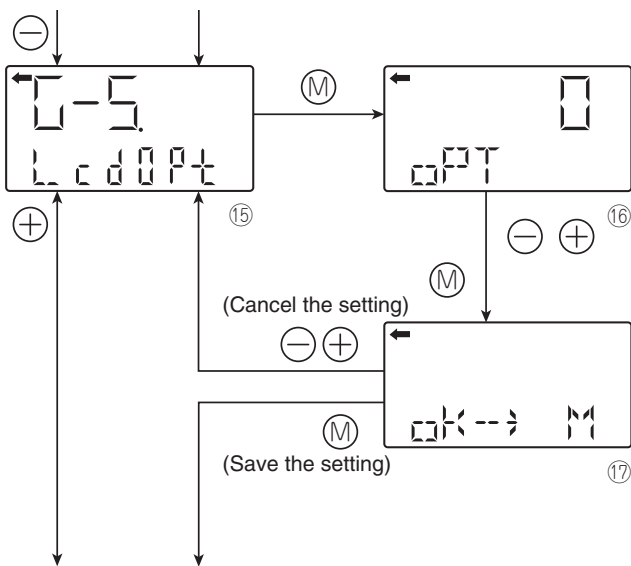

G-5 LcdOPT : LCD unit setting

- Press the **M** key on the screen ⑮ to display the screen for setting the LCD option (⑯).
 - Input the option No. on the screen ⑯ to set the LCD option with the **-** and **+** keys.
- Setting range:

$$0 \leq \text{LCD Option} \leq 3$$

LCD Option	Function
0	Normal display (Display set at G1 to G4)
1	Alternate display (Display set at G1 to G4 and % display [in increments of 1%])
2	Alternate display (Display set at G1 to G4 and % display [in increments of 0.1%])
3	Alternate display (Display set at G1 to G4 and % display [in increments of 0.01%])

- Select whether the option setting is saved on the screen ⑰.
- Press the **M** key to save the option setting.
- Press the **-** or **+** key to cancel the setting.

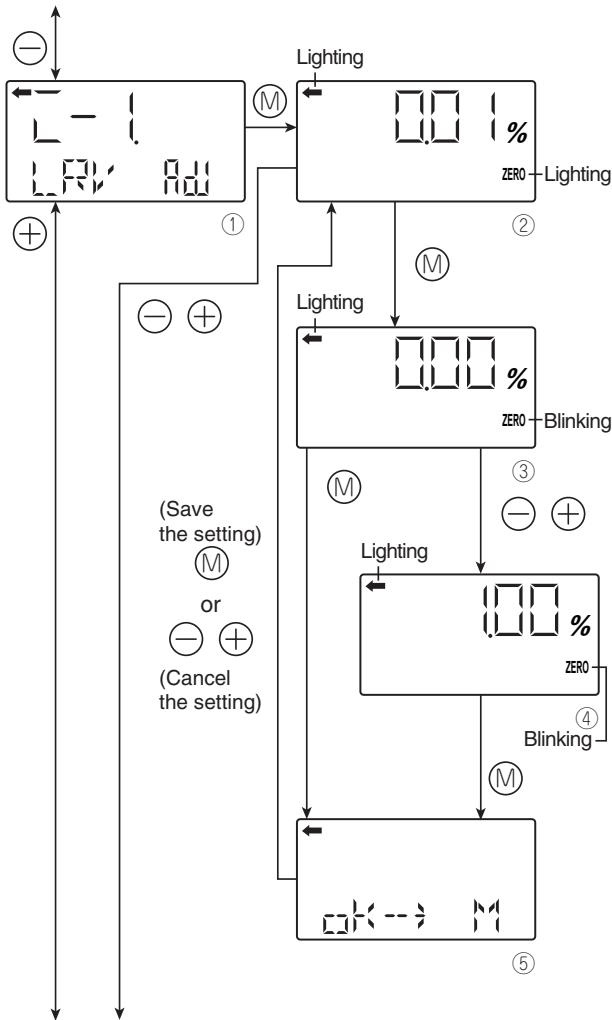

Menu I : Rerange: adjustment by LRV/URV change

(Specially for application to level measurement)
The input-output range adjustment enables you to change automatically the measurement range by re-adjusting the lower limit of the measurement (LRV) or the upper limit of the measurement (URV).

I-1 LRV Adj : Zero adjustment by changing the range (LRV) (LRV adjustment)

- Press the (M) key on the screen ① to select the LRV adjustment mode.
The measured value and unit on the screen ② are the same as those in the normal mode and “←” and “ZERO” light up.
- Apply the reference pressure for LRV (4mA) on the screen ②. After checking the measured value corresponding to 4 mA, press the (M) key.
- “ZERO” blinks on the screen ③. Press the (M) key on the screen ③ to perform a zero adjustment at the input pressure.
Settable range:
-1.00% ≤ LRV (Note 1) ≤ 100.00%
- Select whether the LRV adjustment value setting is saved on the screen ⑤.
Press the (M) key to save the LRV adjustment value setting and return to the screen ②.
Press the (-) or (+) key to cancel the setting and return to the screen ②.
- Check that the zero adjustment (LRV) was performed as intended on the screen ②.
Press the (M) key to perform a zero adjustment again.
Press the (-) or (+) key to move to the next screen for item name selection.

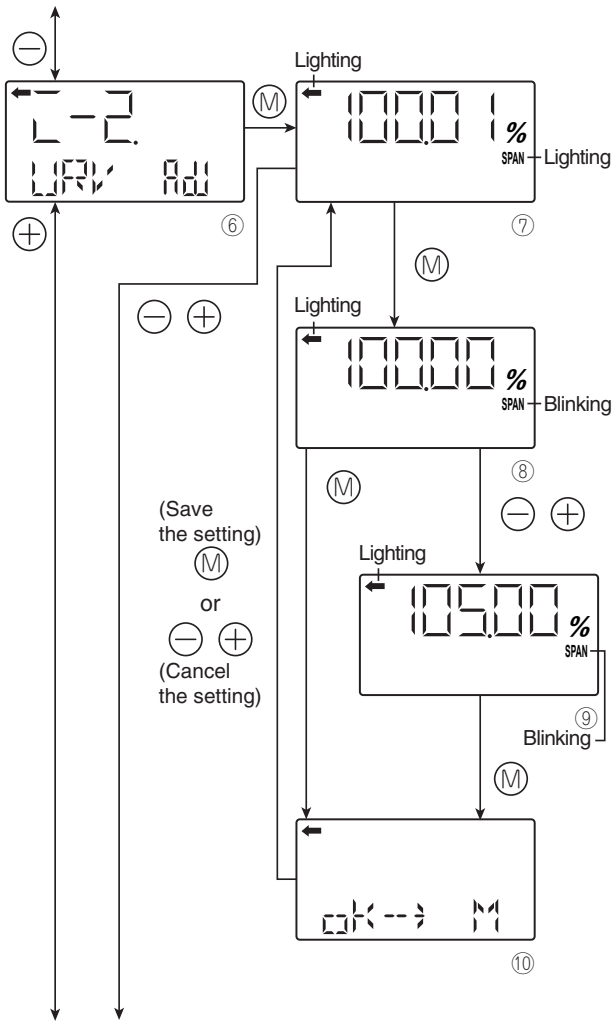

I-2 URV Adj : Span adjustment by changing the range (URV) (URV adjustment)

- Press the (M) key on the screen (6) to select the URV adjustment mode.
The measured value and unit on the screen (7) are the same as those in the normal mode and “←” and “ZERO” light up.
- Apply the reference pressure for URV (20 mA) on the screen (7). After checking the measured value corresponding to 20 mA, press the (M) key.
- “SPAN” blinks on the screen (8). Press the (M) key on the screen (8) to perform a span (100% point) adjustment at the input pressure:
 $0.00\% \leq \text{URV (Note 2)} \leq \text{Saturation current value (upper limit)}$
- Select whether the URV adjustment value setting is saved on the screen (10).
Press the (M) key to save the URV adjustment value setting and return to the screen (7).
Press the (-) or (+) key to cancel the setting and return to the screen (7).
- Check that the span adjustment (URV) was performed as intended on the screen (7).
Press the (M) key to perform a span adjustment again.
- Press the (-) or (+) key to move to the next screen for item name selection.

PROHIBITION

If the input-output is adjusted, the measurement range is changed as shown automatically in the following page.

LRV adjustment

⇒ The measurement range (LRV and URV) are changed. The span is not changed.

URV adjustment

⇒ Only the URV (span) of the measurement range is changed. The zero point (LRV) is not changed.

The following are the setting conditions for the adjustment point:

$-1.00\% \leq \text{LRV (Note 1)} \leq 100.00\%$

$0.00\% \leq \text{URV (Note 2)} \leq \text{Saturation current value (upper limit)}$

Note 1: Output adjustment value (%) corresponding to the input pressure for the LRV adjustment

Note 2: Output adjustment value (%) corresponding to the input pressure for the URV adjustment

Menu J : Saturation current value and specification

You cannot change the saturation current setting if “NoRMAL (normal specification)” is selected at “J-3.” To change the saturation current setting, select “EXP (expanded specification)” at “J-3” as shown in the following page.

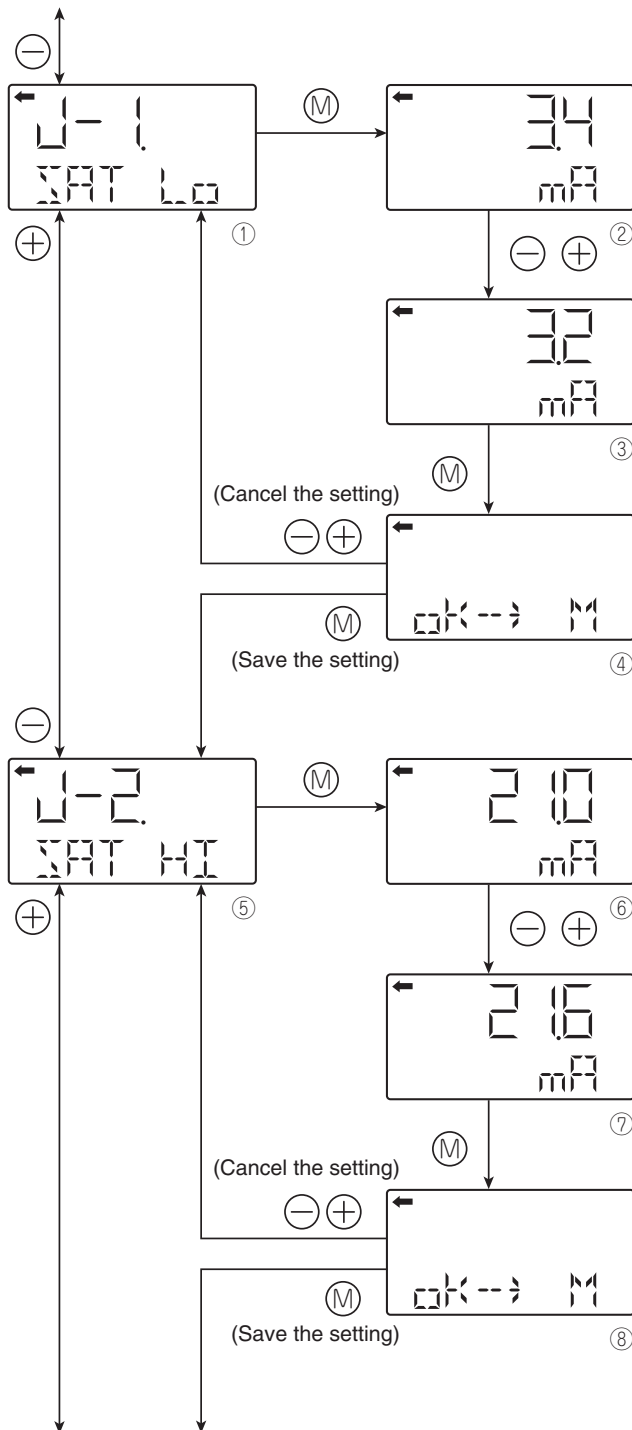

J-1 SAT Lo : Change of the saturation current value (lower limit) (available only when the expanded specification is selected)

- Press the **M** key on the screen ① to display the screen for setting the lower limit of the saturation current (②).

- Input the lower limit on the screen ② with the **-** and **+** keys.

Setting range:

$3.2 \text{ mA} \leq \text{Burnout current (UNDER)} \leq 4.0 \text{ mA}$ but above the saturation current value (lower limit)

- Select whether the lower limit setting of the saturation current is saved on the screen ④.

Press the **M** key to save the lower limit setting.

Press the **-** or **+** key to cancel the setting.

J-2 SAT HI : Change of the saturation current value (upper limit) (available only when the expanded specification is selected)

- Press the **M** key on the screen ⑤ to display the screen for setting the upper limit of the saturation current (⑥).

- Input the upper limit on the screen ⑥ with the **-** and **+** keys.

Setting range:

$20.0 \text{ mA} \leq 21.6 \text{ mA}$ but above the saturation current value (lower limit)

- Select whether the upper limit setting of the saturation current is saved on the screen ⑧.

Press the **M** key to save the upper limit setting.

Press the **-** or **+** key to cancel the setting.

* You can change the burnout current setting at “9: Direction and value of burnout.”

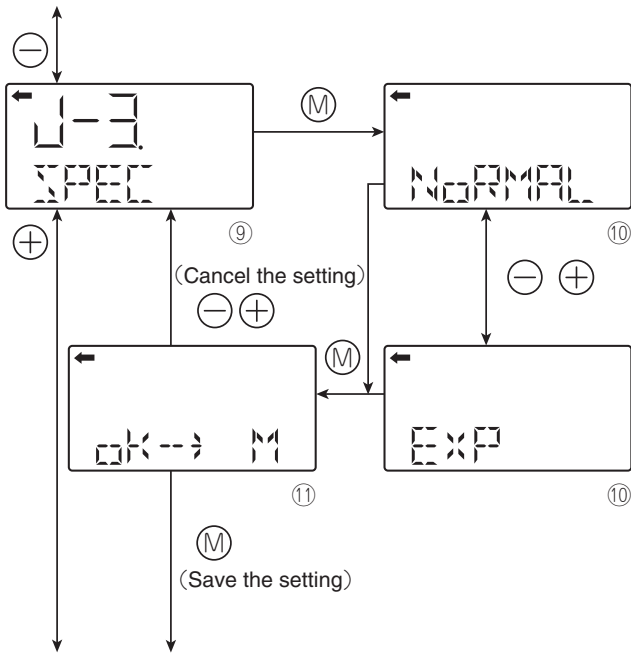

J-3 SPEC : Selection of the burnout & saturation current value specification (normal specification/expanded specification)

- Press the \textcircled{M} key on the screen $\textcircled{9}$ to display the screen for selecting the burnout & saturation current value specification ($\textcircled{10}$).
- Select "NoRMAL (normal specification)" or "EXP (expanded specification)" on the screen $\textcircled{10}$ with the \ominus and \oplus keys.
Select "NoRMAL" for the normal setting.
Select "EXP" for the expanded setting.
* To change the saturation current value (upper limit, lower limit), select the expanded specification.

	Normal specification	Expanded specification
Saturation current value (lower limit)	3.8 mA (fixed)	3.2 mA to 4.0 mA Settable in increments of 0.1 mA
Saturation current value (upper limit)	20.8 mA (fixed)	20.0 mA to 21.6 mA Settable in increments of 0.1 mA

The table below lists the output current value for burnout (OVER, UNDER).

	Normal specification	Expanded specification
Burnout (UNDER)	3.2 to 3.8 mA	3.2 mA to saturation current value (lower limit)
Burnout (OVER)	20.8 to 21.6 mA	Saturation current value (upper limit) to 21.6 mA

The values in the table above can be set in increments of 0.1 mA.

- Select whether the NoRMAL/EXP setting is saved on the screen $\textcircled{11}$.
Press the \textcircled{M} key to save the NoRMAL/EXP setting.
Press the \ominus or \oplus key to cancel the setting and return to the screen $\textcircled{9}$.

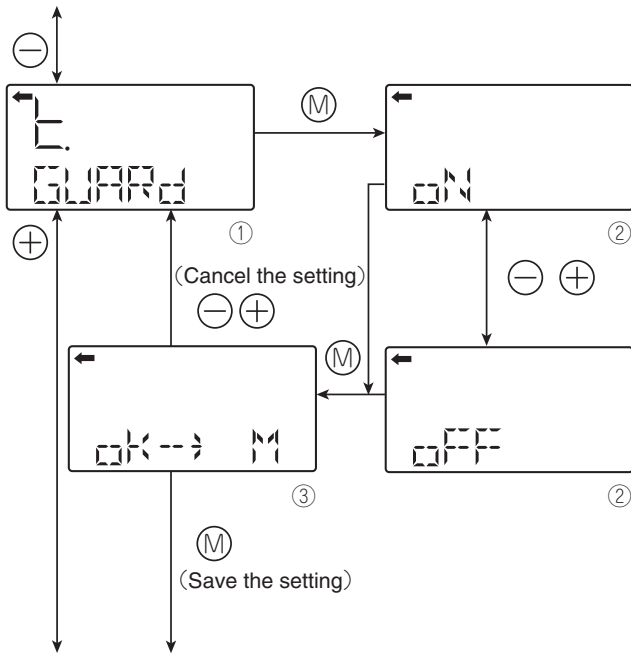

Menu K : Protective function of set value (Write protect)

This function sets and cancels the write protect after password.

The object of write protect are adjustment and setting parameters (including adjustment of external adjustment screw).

After cancelling write protect, it will automatically return to write protect state by setting time.

K-1 GUARD : Setting and canceling write protect

- Press the **M** key on the screen ① to display the screen for setting/canceling write protect (②).
- Select oN (setting)/oFF (canceling) on the screen ② with the **⊖** and **⊕** keys.
To enable write protect, select "ON."
To disable write protect, select "OFF."
- Select whether the selection of oN (setting)/oFF (canceling) is saved on the screen ③.
After selecting oN/oFF, press the **M** key to save the setting.
Press the **⊖** or **⊕** key to cancel the setting and return to the screen ①.

Note:

- If you enable write protect and set a password by the HHC, you cannot cancel the setting with the 3 push buttons and the item name of "K. GUARD" does not appear.
- If you enable write protect by setting the protective function of set value (GUARD) with the 3 push buttons, you can cancel the setting by the HHC.

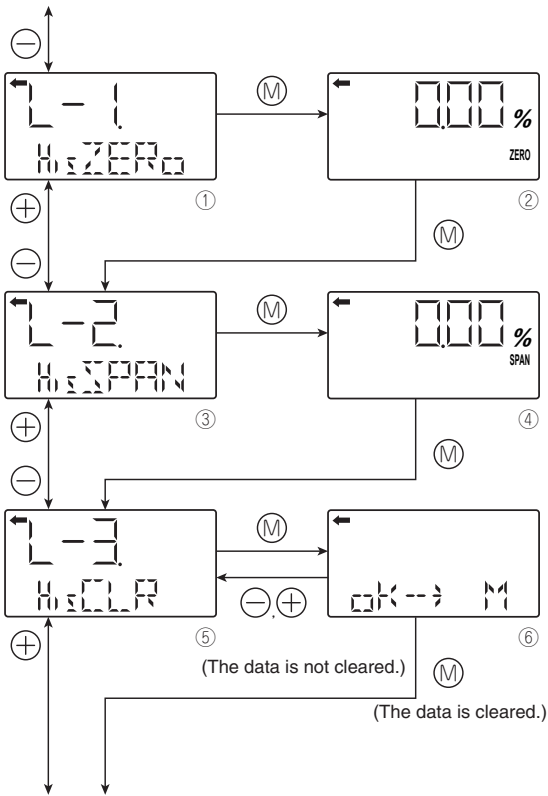

Menu L : Historical data

L-1 HisZERO : Display of zero calibration data for users

- The zero calibration value at the time is displayed.
- Press the **M** key on the screen ① to display the zero calibration value (②).
- Press the **M** key on the screen ② to move to “Display of span calibration data for users.”

L-2 HisSPAN : Display of span calibration data for users

- The span calibration value at the time is displayed.
- Press the **M** key on the screen ③ to display the span calibration value (④).
- Press the **M** key on the screen ④ to move to “Clearing of zero/span calibration data.”

L-3 HisCLR : Clearing of zero/span calibration data

- The zero/span calibration value at the time is cleared.
 - Press the **M** key on the screen ⑤ to display the screen for confirming the zero/span calibration value (⑥).
 - Press the **M** key on the screen ⑥ to clear the zero/span calibration data.
- Press the **-** or **+** key to return to the screen ⑤ without clearing the data.

PROHIBITION

Note that if you clear the zero/span calibration data, the adjusted zero/span calibration value is deleted and reset to the factory default.

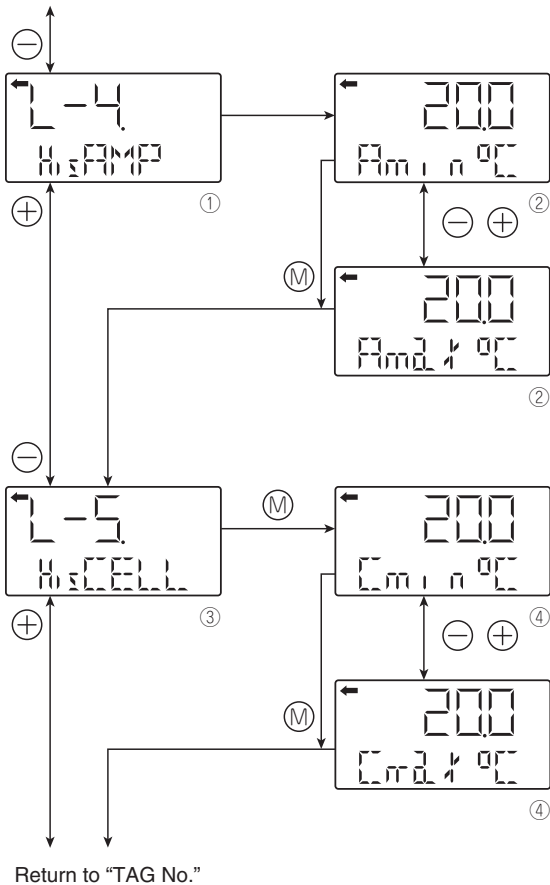

L-4 HisAMP : Display of min/max of amplifier temperature history information

- The min/max values of the amplifier temperature history are displayed.
- Press the \ominus key on the screen ① to display the min/max values of amplifier temperature (②).
- Select and display the min/max values on the display ② with the \ominus and \oplus keys.
Select "Amin" to display the min value of the amplifier temperature history.
Select "Amax" to display the max value of the amplifier temperature history.
- Press the M key on the screen ② to move to "Display of min/max of cell temperature history information."

L-5 HisCELL : Display of min/max of cell temperature history information

- The min/max values of the cell temperature history are displayed.
- Press the M key on the screen ③ to display the min/max values (④).
- Select and display the min/max values on the display ④ with the \ominus and \oplus keys.
Select "Cmin" to display the min value of the cell temperature history.
Select "Cmax" to display the max value of the cell temperature history.
- Press the M key on the screen ④ to return to "TAG No."

6.3 Adjustment with Hand Held Communicator (HHC)



DANGER

In the case of a flameproof transmitter, never connect the HHC to the terminal block of the transmitter in hazardous area installations.

The span adjustment of the transmitter can be done by using the HHC without applying a reference pressure. Here after you will find the wiring of the HHC to modify the transmitter parameters. For the use and the start up of the HHC, please refer to the instructions of FXW (HHC).



INDICATION

After adjustment of the transmitter, it should be kept energized for about 10 seconds.

6.3.1 Connection of HHC

The HHC can be connected in any point of the loop.

To communicate with the HHC, a load resistor of 250Ω mini is required.

Refer the following diagram connection of the HHC (hand Held Communicator).

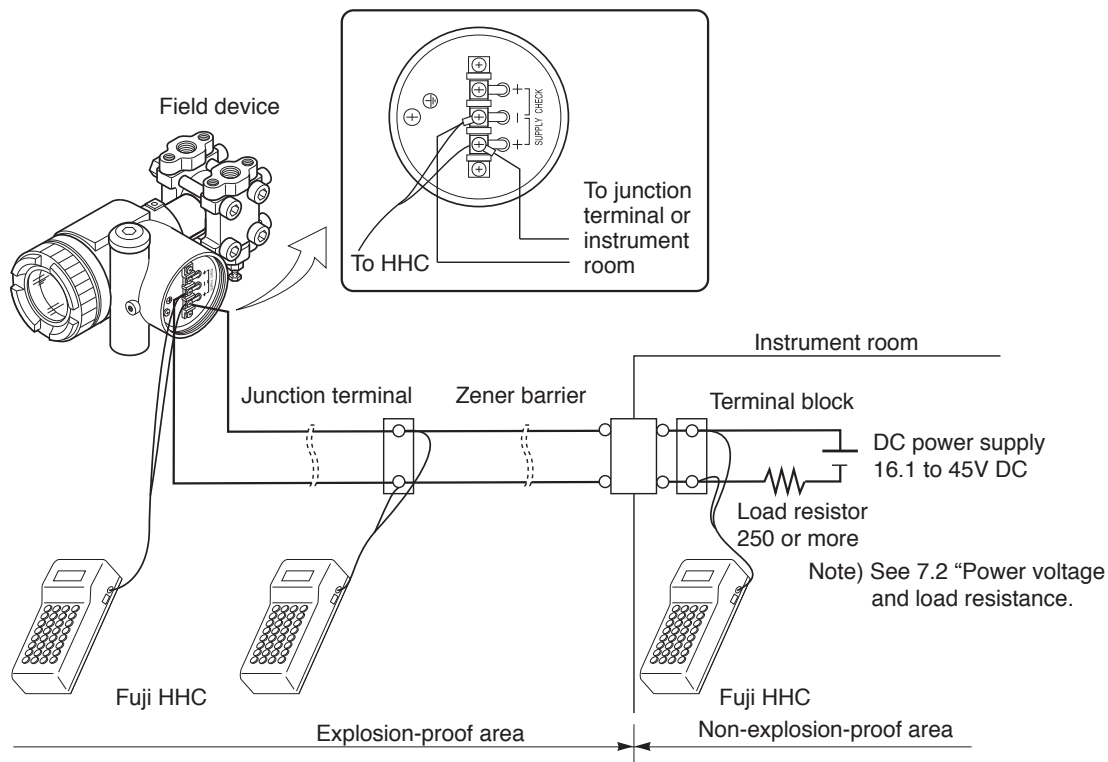

Remarks :

- * The HHC must be on "OFF" position during the connection. It can't be connected to the junction terminal "CHECK + and -" of the transmitter.
- * The HHC has no polarity. (It is possible to connect either the red or black electrical wire to the terminals + or - of the transmitter or on the wires of the loop).



DANGER

In the case of a flameproof transmitter, the HHC can only be connected via the junction box located outside the hazardous area.



6.3.2 Start up of the HHC

- Put on/off switch of the HHC on "ON" position.
Put on the enclosed "key" in the corresponding location of the HHC. Without the key and with the key in vertical position, you can just read the transmitter parameters.
To write new parameters in the transmitter, the key needs to be in horizontal position. Otherwise, you will have an inscription on the HHC screen **"INHIBIT KEY OK ?"** to let you know that the key needs to be turned to enable the programming of new parameters in the transmitter.
Nota : **"INHIBIT KEY"** means that the key permits or inhibits (prohibited) writing parameters in the transmitter
- The transmitter version and the revision of the HHC software are indicated on the screen during the start up.
After around 4 seconds the inscription **"PUSH MENU KEY"** appears (please push menu key) HHC with the optional printer will have the inscription **"PAPER FEED"**. Please push on **<INC>** key. By pushing on **<INC>** key the paper feed is activated.
"PUSH MENU KEY" will be indicated on the screen by if you push on the clear **<CL>** key.
On the screen appears the inscription **"RECEIVING START"**. The HHC reads out the data from the transmitter, and switches automatically in the first programming menu : TAG menu. In case of a connection problem, **"NO CONNECTION"** will appear on the screen. The **"PUSH MENU KEY"** appears again if you push the clear **<CL>** key.
The reasons of a communication problem can be :
 - The 4-20 mA output is not powered.
 - The 4-20 mA is disconnected.
 - The connection between the amplifier unit and the measuring cell is wrong.
 - The loop resistance value doesn't correspond to the required one depending on the power supply.
 - The HHC is not connected to the correct terminals

Configuration menus of HHC

The configuration is based on different menus. The identification of the following program steps are indicated on the bottom line of the screen inside following signs (**<_____>**).

The configuration menus are selectable by pushing on the **INC** (increase: configuration N+1), or the **DEC** (decrease: configuration N-1), keys. The most important menus can be selected with a specific, corresponding key.

The **<CHNG>** (CHANGE, modification) key inside each menu gives the possibility to make modifications or to program new parameters in the transmitter with the alphanumeric keys. To program letters, you first need to push the **<ALPHA>** key, each time before programming the letter. To add a space between characters, you have to push the keys **<ALPHA>**, and **<>**.

To delete characters, please use the clear key **<CL>**.

When the modification is programmed, you have to push the enter key **<ENT>** to send the new information to the transmitter. For safety reasons, you need to confirm the modification a second time by replying on the question **"CHNG OK ?"** . You confirm by typing a second time on the enter **< ENT>** to confirm.

At this moment the new programmed information are written in the transmitter memory, **"WRITE"** indication will appear on the screen of the HHC

The following shows the flow of 21 key operations (n°1 to L), explained for FXW version 7.0 (FXW□□□□1-A4).

FXW prior to Version 7.0 are not available of operation of FCX-A2 V5 serie transmitters. In this case, the user is requested to contact our office for ROM version up.

	Classification		Display symbol	Key symbol	Referential page
1	TAG No.	INC	1 : TAG No.	MENU	73
2	Type	INC	2 : TYPE	MENU ⇨ INC	73
3	Display of serial No.	INC	3 : SERIAL No.	MENU ⇨ INC ⇨ INC	74
4	Industrial value unit	INC	4 : UNIT	UNIT	74
5	Range limit	INC	5 : RANGE LIMIT	UNIT ⇨ INC	75
6	Range change (LRV,URV)	INC	6 : RANGE	RANG	75
7	Damping adjustment	INC	7 : DAMPING	DAMP	76
8	Output mode and value	INC	8 : OUTPUT MODE	LIN / ?	77
9	Burnout direction	INC	9 : BURNOUT	LIN / ? ⇨ INC	78
A	Calibration of the zero/span	INC	A : CALIBRATE	CALB	79
B	Calibration of output circuit	INC	B : OUTPUT ADJ	OUT	80
C	Indication of measured data	INC	C : DATA	DATA	81
D	Self-diagnosis	INC	D : SELF CHECK	DATA ⇨ INC	81
E	Printer function	INC	E : PRINT	DATA ⇨ INC ⇨ INC	82
F	Lock of adjustment functions	INC	F : XMTR EXT.SW	DATA ⇨ INC ⇨ INC ⇨ INC	82
G	Indication of digital indicator	INC	G : XMTR DISPLAY	DATA ⇨ INC ⇨ INC ⇨ INC ⇨ INC	83
H	Programmable linearization function	INC	H : LINEARIZE	DATA ⇨ INC ⇨ INC ⇨ INC ⇨ INC ⇨ INC	86
I	Rerange (Set LRV/URV calibration)	INC	I : RERANGE	DATA ⇨ INC ⇨ INC ⇨ INC ⇨ INC ⇨ INC ⇨ INC	88
J	Saturation current value and specification setting	INC	J : SATURATE CUR	DATA ⇨ INC ⇨ INC ⇨ INC ⇨ INC ⇨ INC ⇨ INC ⇨ INC	89
K	Write protect	INC	K : WRITE PROTCT	DATA ⇨ INC ⇨ INC ⇨ INC ⇨ INC ⇨ INC ⇨ INC ⇨ INC ⇨ INC	90
L	History information	INC	L : HISTORY	DATA ⇨ INC ⇨ INC ⇨ INC ⇨ INC ⇨ INC ⇨ INC ⇨ INC ⇨ INC ⇨ INC	91

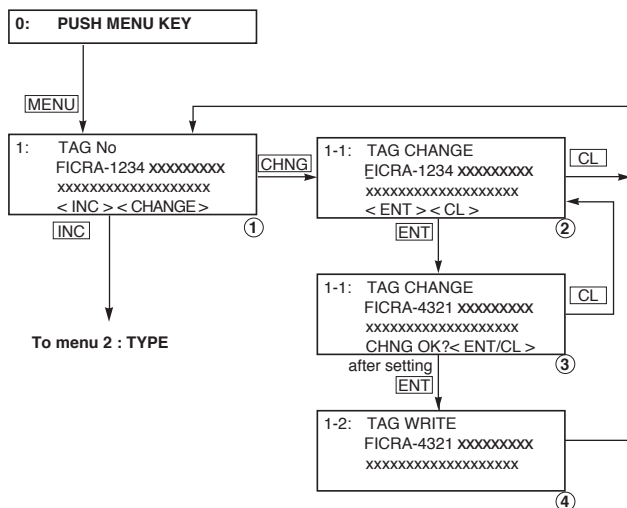

Menu 1 : Tag N°

To set the TAG N° of the transmitter, use the procedures shown in the following diagram.

TAG N° can be inputted up to 26 characters of alphanumeric codes.

- After **PUSH MENU KEY** is displayed, press the **<MENU>** key to display TAG N°.
- To make changes press the **<CHNG>** key and the cursor will be displayed under display ①.
- Set the alphanumeric keys as necessary under display ②.

To set the alphabet, press the **<CHNG ALHA>** key first.

Using **< < >> >** keys, cursor position can be moved.

- At the completion of setting, press the **<ENT>** key.
- If the entry is correct, press the **<ENT>** key to input it to the field device under display ③ and ④ and the initial image ① is displayed. Otherwise press **<CL>** to come back to the modification display ②.
- To display TYPE display, press the **<INC>** key under display ①.

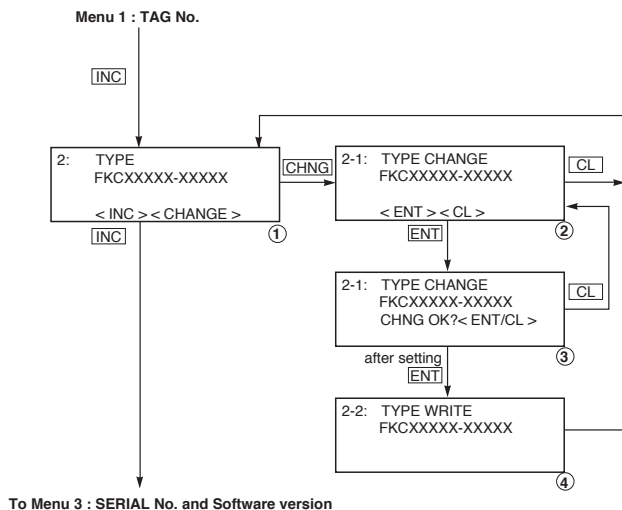

Menu 2 : Type

Model code of field device is displayed and changed (ex. of differential pressure transmitter).

- After TAG N° is displayed, press the **<INC>** key to display TYPE image.
- To make changes press the **<CHNG>** key under display ① and the cursor will be displayed under display ②.
- Set the alphanumeric keys as necessary under display ②. To set the alphabet, press the **<CHNG ALHA>** key first.

Using **< < >> >** keys, cursor position can be moved.

- At the completion of setting, press the **<ENT>** key and a prompt is displayed check entry under display ②.
- If the entry is correct, press the **<ENT>** key to input it to the field device under display ③ and ④ and the initial image ① is displayed. Otherwise press **<CL>** to come back to the modification display ②.
- To display SERIAL N°, press the **<INC>** key under display ①.

2 : TYPE

[INC]

3: SERIAL No.
N8G07131
VERSION 1.1
< INC >

[INC]

To menu 4 : ENGINEERING UNIT

Menu 3 : Serial N°

SERIAL N° and transmitters software version are displayed.

- After setting TYPE, press the <INC> key to display SERIAL N° and software version of transmitter.
- By pressing the <INC> key, UNIT setting image is displayed.

Menu 3 : SERIAL N°

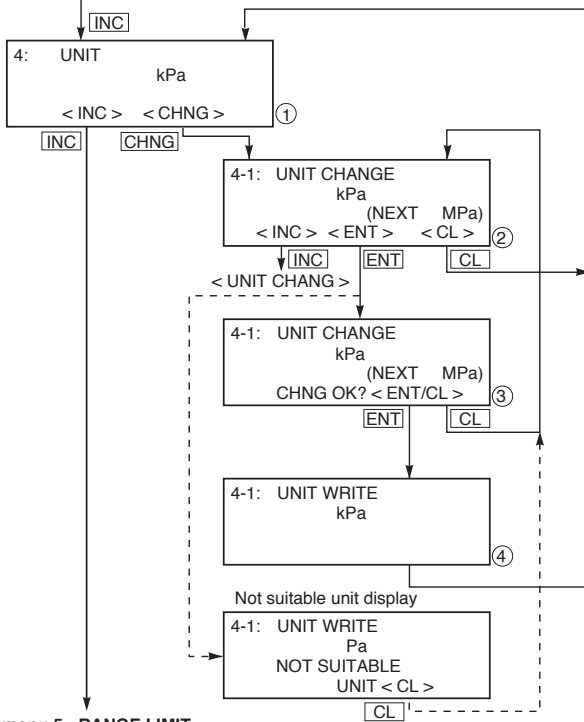

Menu 4 : Engineering unit

26 industrial units can be used by the operator (see below).

Note: the mark < > is settable for absolute pressure transmitter only.

- When pressing <CHNG> under display ①, the display for changing the engineering unit ② appears.
- The desired engineering unit is selectable by using <INC> or <DEC> under display ②.
- Display ③ is provided for confirming your change.
- Display ④ is for registering the engineering unit.

- mmH₂O
- cmH₂O
- mH₂O
- g/cm²
- kg/cm²
- Pa
- hPa
- kPa
- MPa
- mbar
- bar
- psi
- inH₂O
- ftH₂O
- mmAq
- cmAq
- mAq
- mmWC
- cmWC
- mWC
- mmHg
- cmHg
- mHg
- inHg
- < Torr >
- < atm >

[INC]

[DEC]



The unit of industrial value is set according to the range as ordered, but the display resolution lowers depending on the unit being set.

When

4-1:UNIT CHANGE
Pa
NOT SUITABLE
UNIT <CL>

is displayed upon changing the unit of industrial value, output cannot be displayed in the engineering unit selected.

In this case, press the [CL] key and change the engineering unit to a different one.

Menu 5 : Range Limit

Indicates the maximum measuring range of this transmitter.

- After setting engineering unit, press **<INC>** key to display RANGE LIMIT.
- By pressing the **<INC>** key, RANGE setting image is displayed.

Menu 6 : Range change (LRV, URV)

LRV: Lower range value (0% point - 4 mA)

URV: Upper range value (100% point - 20 mA)

Selectable setting range

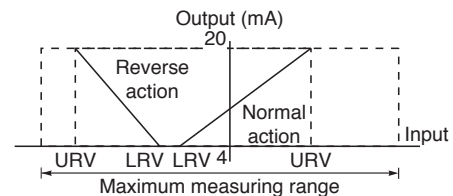

Note) If the set value of the LRV is outside the range, an error also occurs (SetERROR) in the URV setting, and vice versa.

The maximum setting range is ± 9999 .

The URV may exceed the upper limit depending on the change of the Unit. If that happens change the URV first.

- When pressing **<CHNG>** under display ①, display changes to the LRV and URV selection screen.
- Press **<LRV>** for presenting the display for setting the zero point range (display ③).
- Press **<URV>** for presenting the display for setting the span range (display ④).
- Under displays ③ or ④, input zero point or span values. Press **<ENT>** after setting LRV or URV. Note : when pressing **<+>** or **<->** under display ③ or ④, negative value is available. Note : if the set value of the LRV is outside the range, an error ("setting error") also occurs in the URV setting, and vice versa. The maximum setting range is ± 99999 . The URV may exceed the upper limit depending on the change of the UNIT. If that happens, change the URV first.

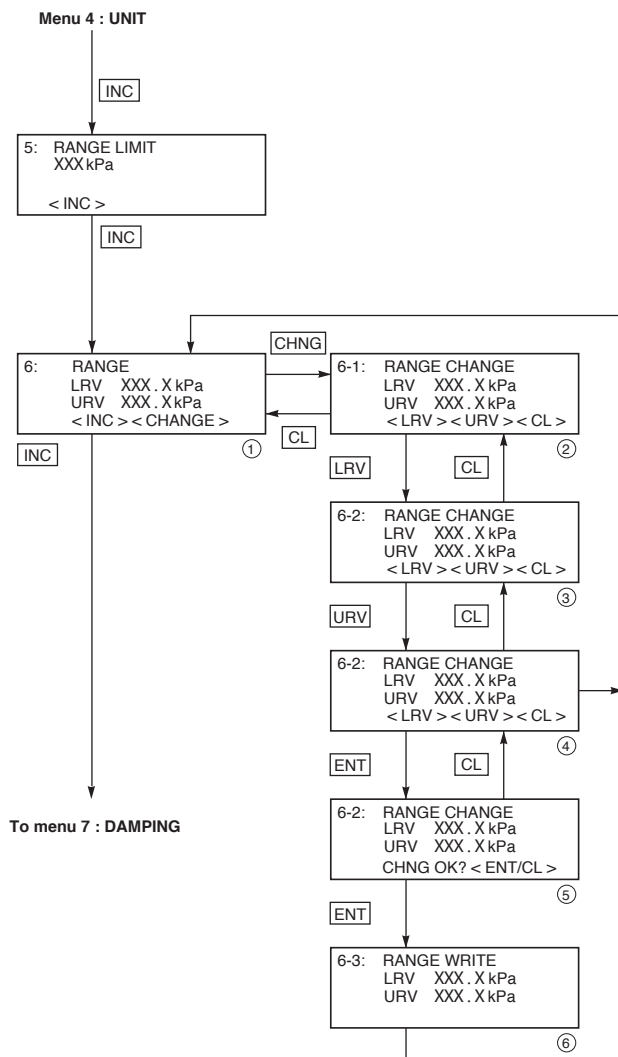

The setting range of the transmitter is independent of the setting range of the indicator. After changing the range in this menu, it is necessary to change the range in the LCD indicator (menu G). Using an analog indicator and the transmitter range is changed, replacement of the analog indicator is required.

Menu 7 : Damping Adjustment

In the case where the process input fluctuation or the vibration of the installation site is important, it is required to set appropriate damping time to avoid the output fluctuation.

- Input time constant value under display ②, damping can be changed.
- Press <ENT> after setting damping
- Press <CL> under display ③ to come back to the modification display ②.

Selectable time constant value :
0.04 to 32 sec (two significant figure)

Note 1) In the case of FCX-All series transmitters with safety function, when there are no damping, then 0.12 sec is appeared on HHC.

Note 2) The above damping constants are used only for the electronics unit. The detecting unit has its own constants independent of the electronics unit (for details, refer to the data sheet).

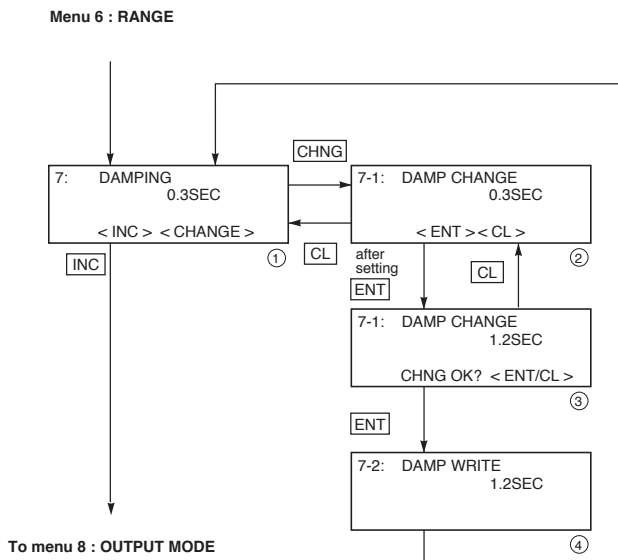

Menu 8 : Output Mode

The output mode is used to select the proportional mode (proportional to input differential pressure) or square root extraction mode (proportional to flow rate) for output signal (4 to 20mA) of the differential pressure transmitter only.

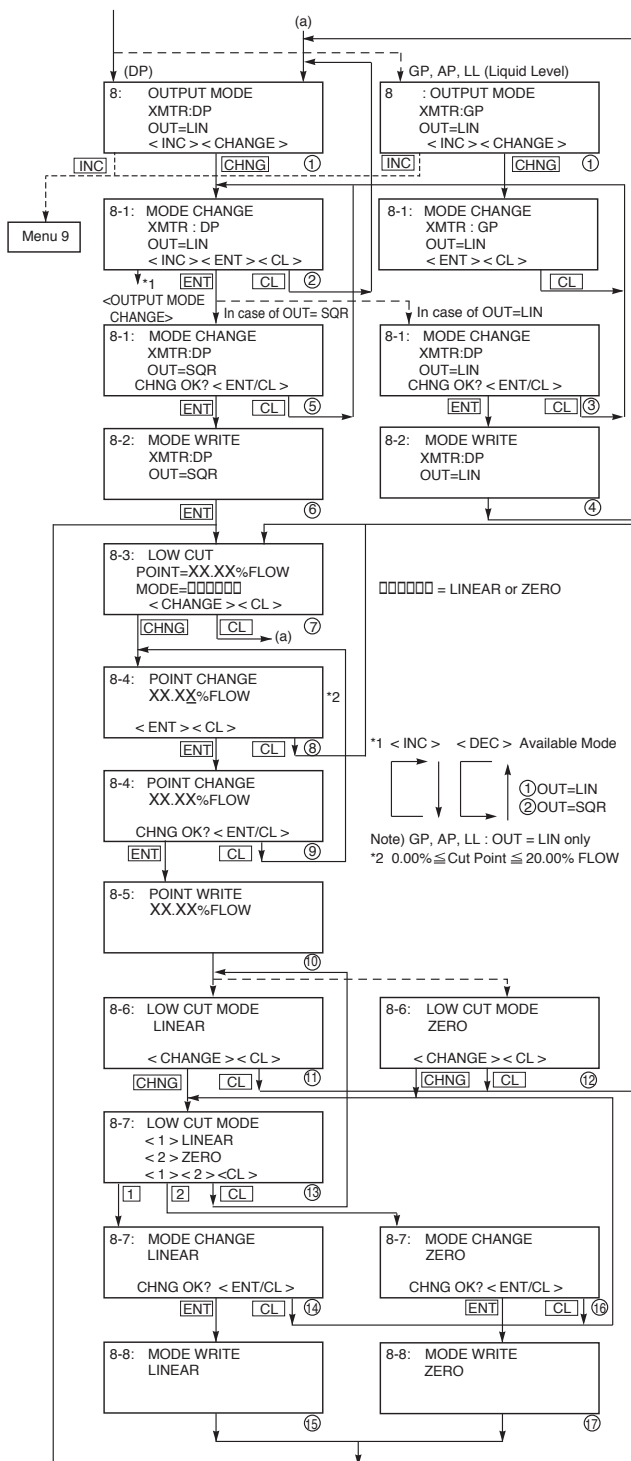

8-1 Change the output mode

In case of square root extraction mode, the cut point and the mode below the cut point can be set.

- Under display ②, press <INC> or <DEC> for selection of the square root extraction mode ("SQR") or linear mode ("LIN").

8-3 Low cut point setting

The square root extraction mode is selected, the display ⑦ is presented and the low cut point should be set.

Note that if the cut point is set to a small value around 0%, even a minute differential pressure change causes a sudden output fluctuation. The cut point is used for improving the measurement in case of low flowrate.

There are two modes :

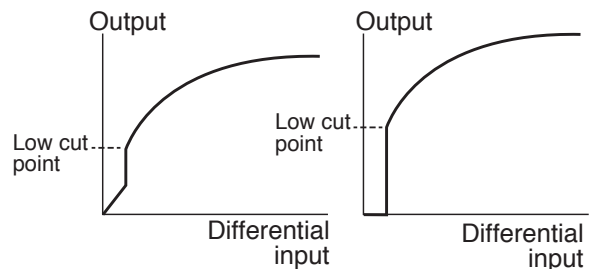
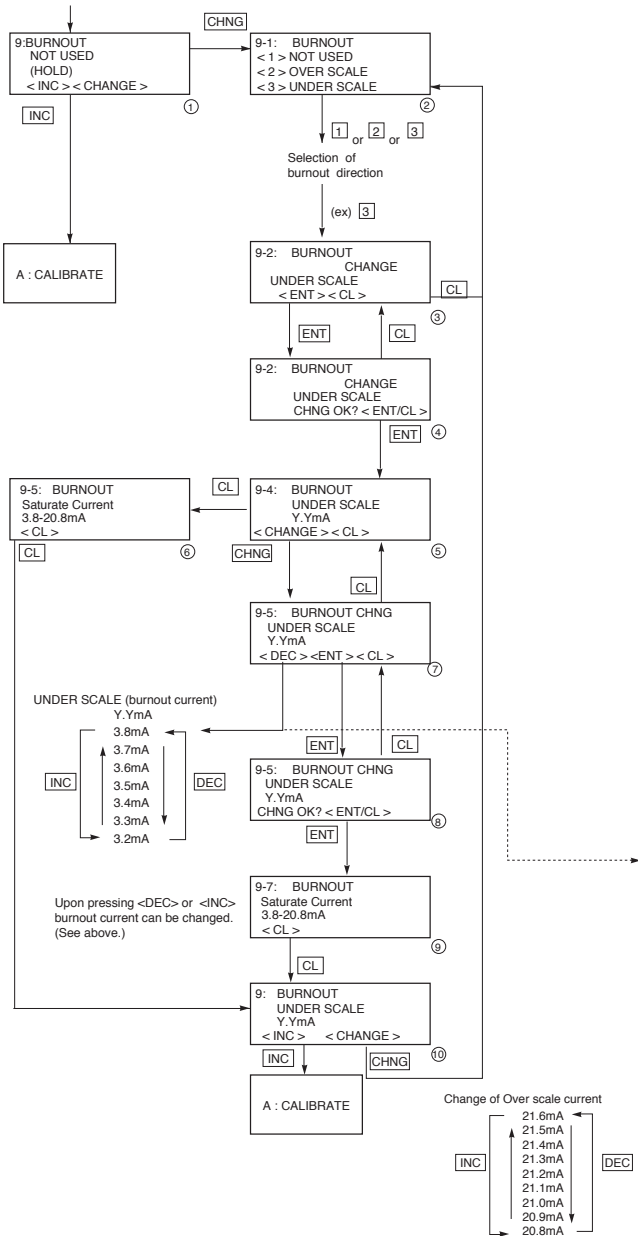

Fig. A: With linear output selected in low cut mode

Fig. B: With zero output selected in low cut mode

- On display 11, press "CHANGE" to set the low cut mode
- Under display ⑬, linear or zero output is selectable for output below the cut point.



Menu 9 : Burnout direction

Used for selecting output at occurrence of a fault in the detecting unit.

- Burnout direction is selectable under display ②
 - For selection of UNDERSCALE, press <1>.
 - For selection of OVERSCALE, press <2>.
 - For selection of UNDER, press <3>.
- For NAMUR specification, the meaning of each condition above is as follows.
- NOT USED → Not used (Output hold)
Saturation current = current set value
Note) Output value just before the occurrence of trouble is given in the output hold mode.
 - OVER SCALE → Over scale (Output 20.8 to 21.6mA)
Saturation current = current set value
 - UNDER SCALE → Under scale (Output 3.2 to 3.8 mA)
Saturation current = 3.8, 20.8mA

For NAMUR specification :
3.4 mA => Burnout (UNDER) ≤ 3.6 mA

- Press "ENT" to confirm the setting.

Change of burnout current for OVERSCALE and UNDERSCALE

- On display (5), press "CHANGE" to set the burnout current.
- Press "DEC" or "INC" to change the burnout current (settable in increments of 0.1 mA) on display ⑦.
- Press "ENT" to confirm the setting otherwise press "CL" to cancel the setting on display ⑧.
- Display ⑨ with saturate current appears.

Note :

Specification of the saturation current value (Upper limit and Lower limit) is changeable according to the Menu "J : Saturation current value" The over limit value of saturation value is settable up to 4.0 mA at Custom specification (3.2 mA to 4.0 mA)

Display symbol of Menu 9 is : "9 : BURNOUT EXP" at Customs specification.

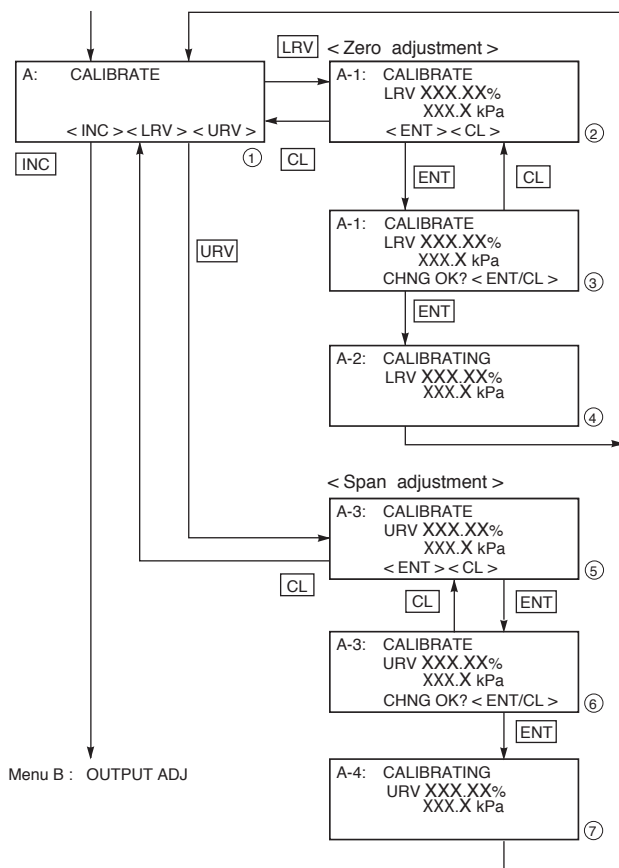

Menu A : Zero/span calibration

Configuration menu A “CALIBRATE” gives the possibility to calibrate zero and span of the transmitter (LRV and URV).

The ranging of the transmitter needs to be done in the “RANGE” menu 6.

Please use menu A “CALIBRATE” only when the LRV and URV are fixed in the “RANGE” menu. It is absolutely necessary to apply an accurate reference pressure corresponding to the zero or LRV point as well as the span or URV point when making a calibration.

Calibration of the Low Range Value (LRV)

- In the display ①, press "LRV" to reach display ②
- Press "ENT" to make the LRV calibration (at 0% - 4mA) Reference pressure for 0% (4mA) must be applied on the transmitter at this moment.

For example : LRV range : 0 bar gauge.

Open the transmitter drain to the atmosphere and make a LRV calibrate.

Calibration of the Upper Range Value (URV)

- In the display 1, press "URV" to reach display ②
- Press "ENT" to make the URV calibration (at 100% - 20mA) Reference pressure for 100% (20 mA) must be applied on the transmitter at this moment.

Calibration at any point other than 0 and 100%

- In the display 1, press "LRV" or "URV" to reach display ② or ⑤
- Enter the pressure value at that point in the display ② or ⑤
- Press "ENT" to make the calibration while applying a corresponding pressure to the transmitter.



Press LRV or URV at display of ①.

When the following is displayed, it means that calibration can not be made because Menu No. H: LINEARIZE is effective. In this case, set INVALID on the panel of No. H: LINEARIZE.

```
A-1:CALIBRATE
Can't proceed.
Set Linearize
invalid      <CL>
```

1. Span adjustment should be performed after zero adjustment is completed.
2. When the actual input exceeds the adjustable range, [NOT CALB <CL>] is displayed. In this case, adjustment is required again.

Adjustable range

Zero adjustment : Within ±40% of maximum span

Span adjustment : Within ±20% of calibrated span

3. When the adjustment point does not meet the following condition, [SETTING ERR<CL>] is displayed. In this case, adjustment is required again.

Adjustment point setting condition

$$-1.000\%CS^{(*)} \leq PL \leq 100.000\%CS^{(*)} \quad 0.000\%CS^{(*)} \leq PH \leq 105.000\%CS^{(*)}$$

$$PL = \frac{(\text{Lower adjustment point}) - LRV}{URV - LRV} \times 100$$

$$PH = \frac{(\text{Higher adjustment point}) - LRV}{URV - LRV} \times 100$$

(*) : CS (Calibrated Span) is equal to measuring range.



Menu B : Calibration of output circuit D/A

The transmitter has a numerical electronic. The cell signals are processed by a microprocessor and sent to a digital/analog D/A converter to convert the signal in 4-20 mA.

This menu allows to calibrate the D/A converter. It is necessary to connect a milliamperemeter (accuracy +/- 1micro A) to check the output signal.

This menu allows too to check, with a 4-20 mA signal, the measuring loop.

The output circuit (D/A) should be calibrated by the following procedure when necessary.

Make transmitter connection according to "Calibration" in appendix A2, and calibrate the output circuit using the following procedure.

- When the <LRV> key is pressed at the display of ①, the display ② for 4mA current output and its calibration will appear on the screen. During this phase, a 4mA constant current is generated.

- Press "CALB" for the calibration
- Press "CHNG" or "CL" to cancel

- When the <URV> key is pressed, the display ⑦ for 20mA current output and its calibration will appear on the screen. During this phase, a 20 mA fix current is generated.

- Press "CALB" for the calibration
- Press "CHNG" or "CL" to cancel

Under display ①, input a desired value within a range of 3.8 to 20.8mA and then press <ENT> to generat a constant current.

- Press "CHANGE" or "CL" to cancel.

Under display ④, input digital values measured by digital voltmeter.

Under display ④, the output circuit is calibrated when pressing <ENT>.

The transmitter will calculate automatically the gap between the theoritical and the measured values. It will rectify in the D/A converter.

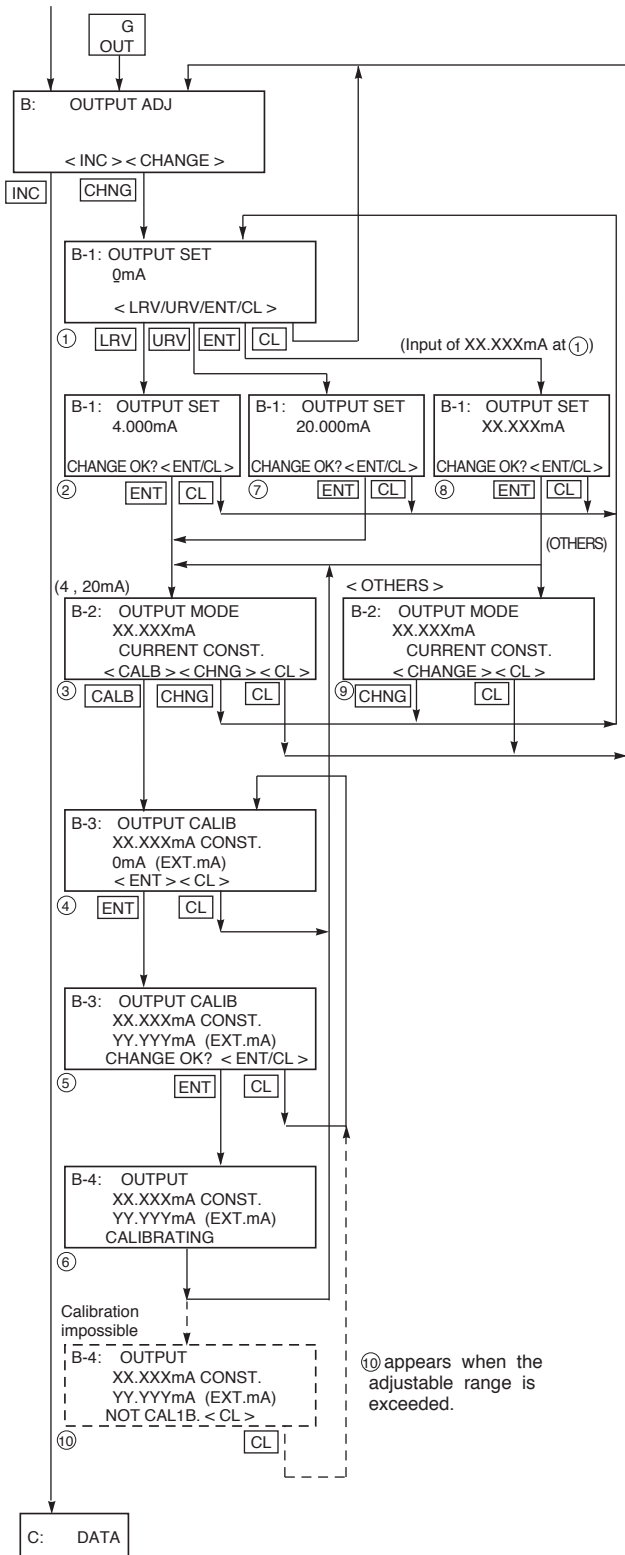

After setting and calibrating the constant current output, be sure to reset the HHC display to cancel with the initial display of menu B.

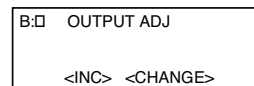

It should be noted that if HHC is removed from the transmitter loop or the HHC power is turned OFF when the constant current output has been set, the transmitter output is retained at the constant current output.

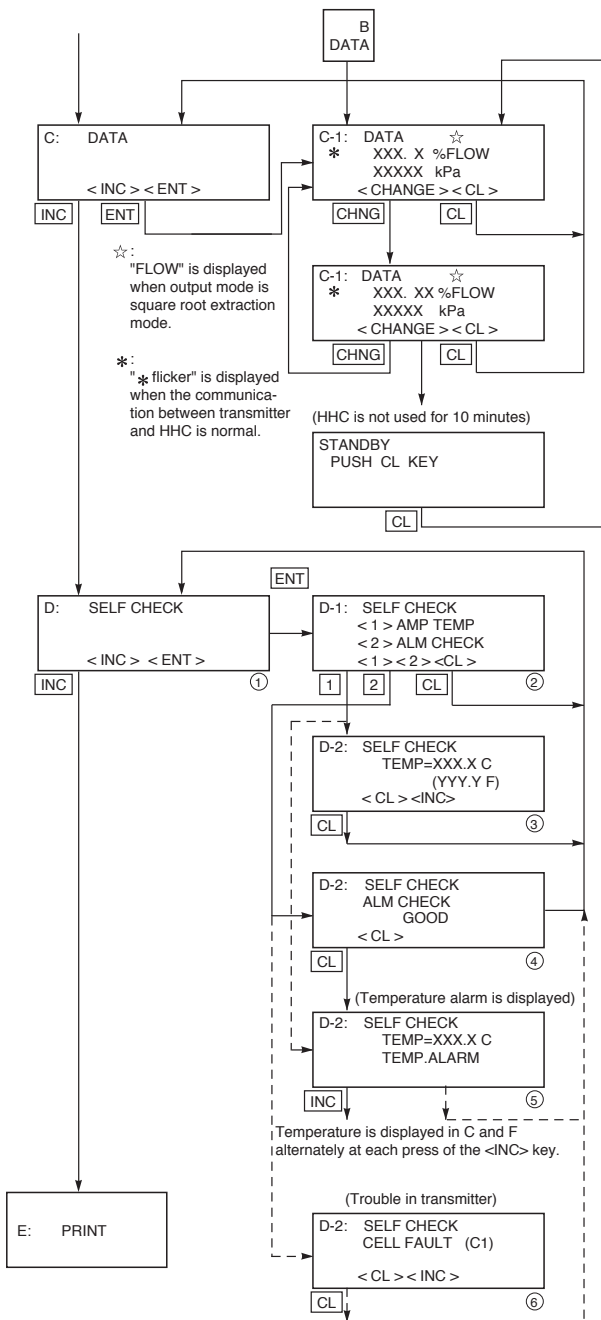

[Contents of message]

As a result of self-diagnosis, the message below is appeared on the LCD display of HHC, when there are trouble in the transmitter. For each error, its cause and remedy are suggested.

Message	Indication on digital indicator	Cause	Remedy
CELL FAULT (C1) }	FL-1	Error of detecting unit	Replacement of detecting unit
CELL FAULT (C9) ^(*)			
EEPROM (AMP) FLT	FL-2	EEPROM error on amplifier side	Replacement of amplifier
EEPROM (CELL)	FL-3	EEPROM error on cell side	Replacement of detecting unit
FLT TEMP. ALARM	^(*) T.ALAM	Transmitter temperature is not within the allowable range (-40 to 85°C).	Transmitter temperature is normalized.
	FL-1	Amplifier error	Replacement of amplifier
XMTR FAULT	^(*) OVER	Input pressure is 105% or higher of setting range.	Properly controlled.
	^(*) Under	Input pressure is -1.25% or lower of setting range.	Properly controlled.

(*) Real indication

Menu C : Indication of measuring data

The measured value is indicated.
 Flashing "*" indicates the transmission of the measurement value to the HCC.
 the digital number for the "%" can be set pressing "CHNG".
 The HCC will be in stand by after 10 min without any operation. Press "CL" to avoid the stand by and come back to the display with the measuring data...

Menu D : Self-diagnosis

Use for displaying the measured temperature in the transmitter and the alarm information.

- When pressing <1> on display ②, the temperature in the amplifier (AMP TEMP) is displayed.
- When pressing <2>, result of self-diagnosis about transmitter (ALM CHECK) is displayed.

Result of diagnosis

When the temperature in the amplifier is normal:

```
D-2: SELF CHECK
TEMP= xxx.x °C
<CL>
```

When temperature alarm is detected:

```
D-2: SELF CHECK
TEMP= xxx.x °C
TEMP. ALARM
<CL>
```

When no error has occurred:

```
D-2: SELF CHECK
ALM CHECK
GOOD
<CL>
```

When an error has occurred:

```
D-2: SELF CHECK
CELL FAULT (C1)
<CL> <INC>
```

For contents of error, refer to "Contents of message".

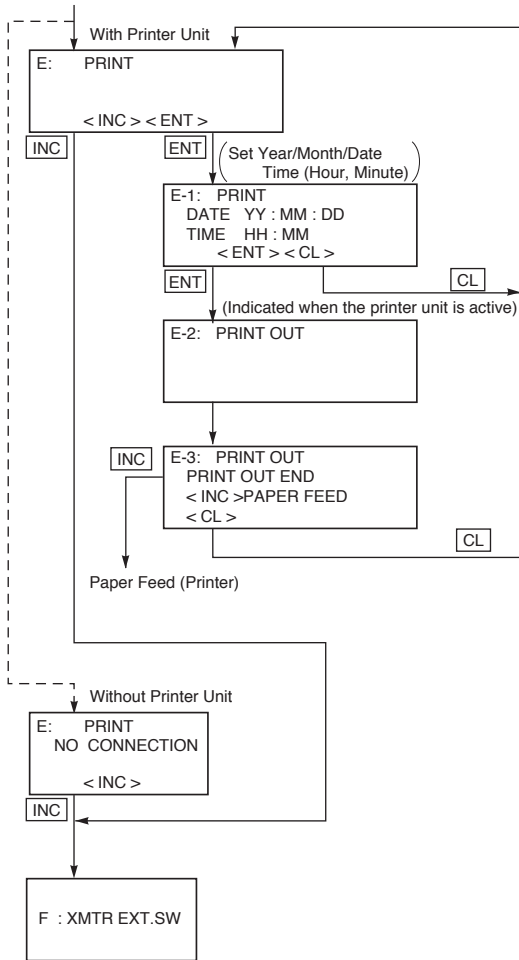

Menu E : Printer function

Usable only when a printer is connected.

All transmitter setting can be print with the printer connected to HHC.

If the printer is not connected, "NO CONNECTION" appears on the display.

- Press <ENT> to launch the printing and setting the Year/ Month/Date and Time.
- Press <ENT> to confirm
- "PRINT OUT" is displayed and the printing begins

At the end, "PRINT OUT END" is displayed.

- Press <INC> to have paper feed otherwise press <CL> to come back the menu E display.

Note :

10 parameters are printed : TAG, SN, TYPE, URL, RANGE, DAMPING, BURNOUT, DAT, TEMP and RAS)

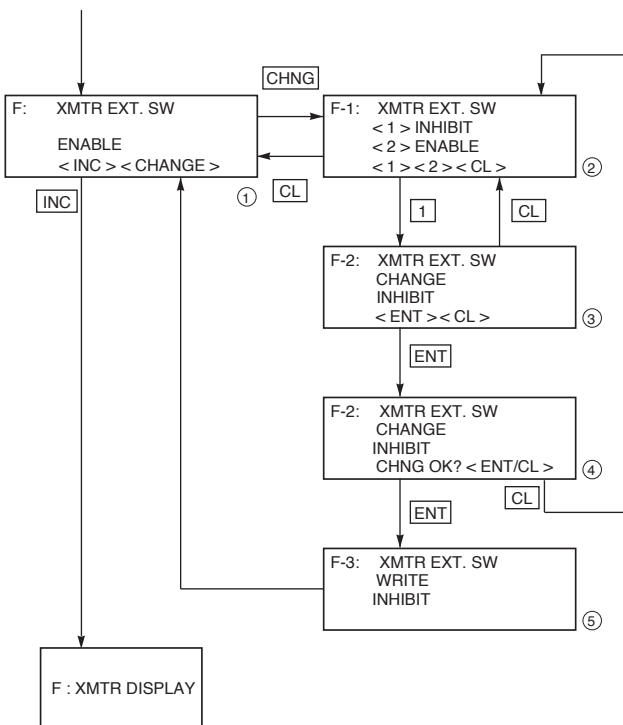

Menu F : Lock of adjustment function

This menu allows to lock and unlock the adjustment function by local configurator unit with LCD and by external screw.

When pressing <1> (INHIBIT) under display ②, the external switch lock function is activated and all adjustment function of the transmitter by LCD are locked and it is released when pressing <2> (ENABLE).

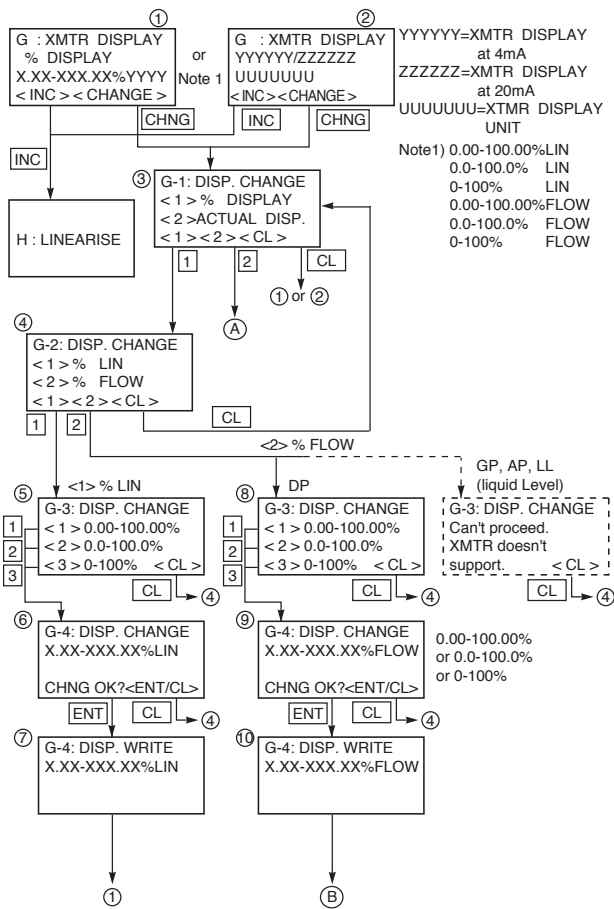

Menu G : Setting of LCD display

The LCD display is independent of the transmitter setting. So the LCD display must be set.

For digital indicator, either % display or actual-scale display is selectable. In display on the actual scale, display values corresponding to 0% (4mA) and 100% (20mA) are settable.

Linear / Flow setting

Then linear mode and square root extraction mode is selectable as shown in ④.

<1> % LIN (for flow measurement) is displayed in % in the linear mode

<2> % FLOW is set by % in the square root extraction mode (proportional to flow)

Note : in case of pressure transmitter, absolute pressure transmitter and level transmitter,

<2> % FLOW cannot be set in ④.

- Display 5 allows to set the decimal point of the value on the digital indicator.

- After choosing (<1>, <2> or <3>) press <ENT> to confirm otherwise <CL> to cancel.



Range setting for linear mode

After choosing <2> on display ①, the LCD range is shown.

If the LCD range is different of the transmitter range, it is necessary to change the LCD range.

- Press <LRV> or <URV> to change the LRV/URV range of the digital indicator
- Enter the LRV and the URV on displays ⑫ or ⑬.
- Press <ENT> to confirm otherwise press <CL> to cancel.

Note :

- The following scale can be set :
 $-99999 \leq LDV$ (without decimal point) ≥ 99999
 $-15000 \leq UDV-LDV \leq 15000$
- When entering the range in the displays ⑫ or ⑬, do not forget to enter the number with the same decimal point as defined in <% Display>.

Unit setting for linear mode

After setting the LCD range, the display 16 is shown to set the unit.

- Press <CHANGE> on display ⑯
 - Choose the unit type on display ⑰ (PRESS, LEVEL, FLOW)
 - Choose the unit on display ⑱
 - Press <ENT> to confirm the unit otherwise press "CL" to cancel.
- Data is written in the Digital indicator of the transmitter.

Note :

In case of pressure transmitter, absolute pressure transmitter and level transmitter, the flow units cannot be set.

CAUTION

Indication of the transmitter digital indicator may have ±1 digit error against the setting by HCC

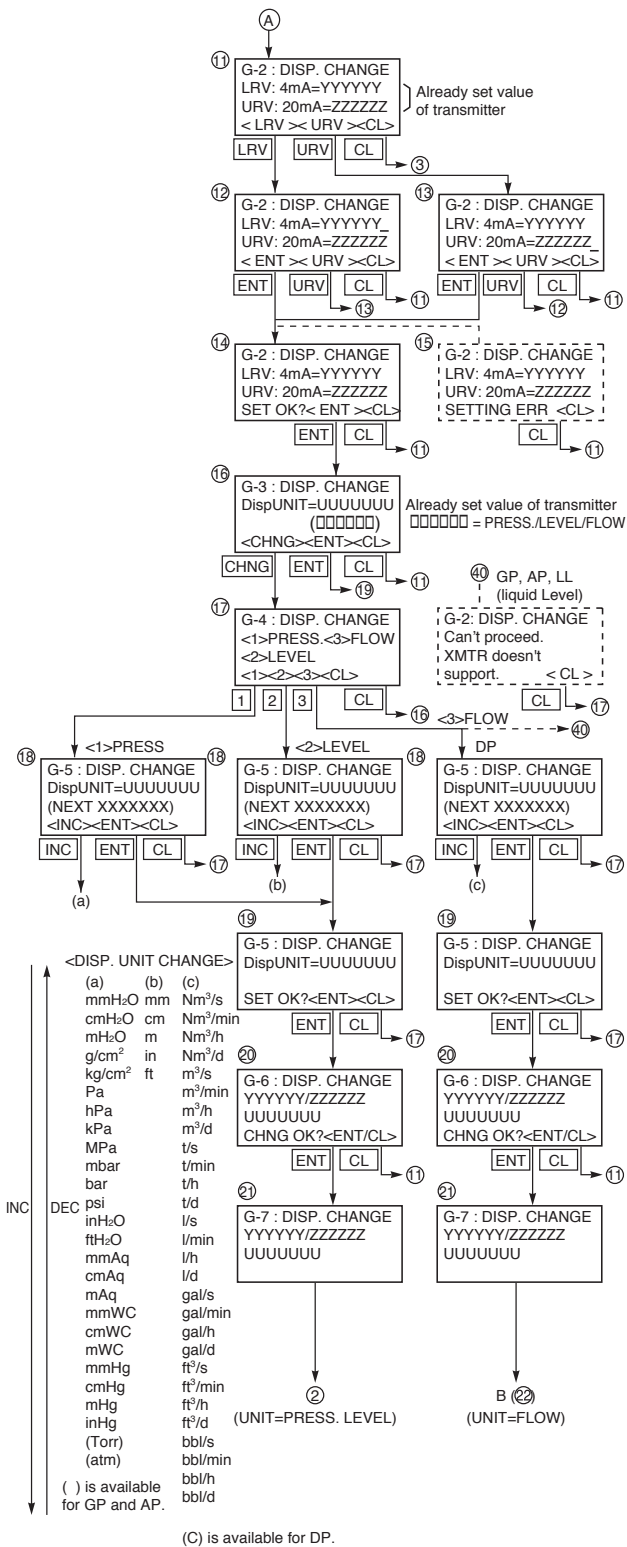

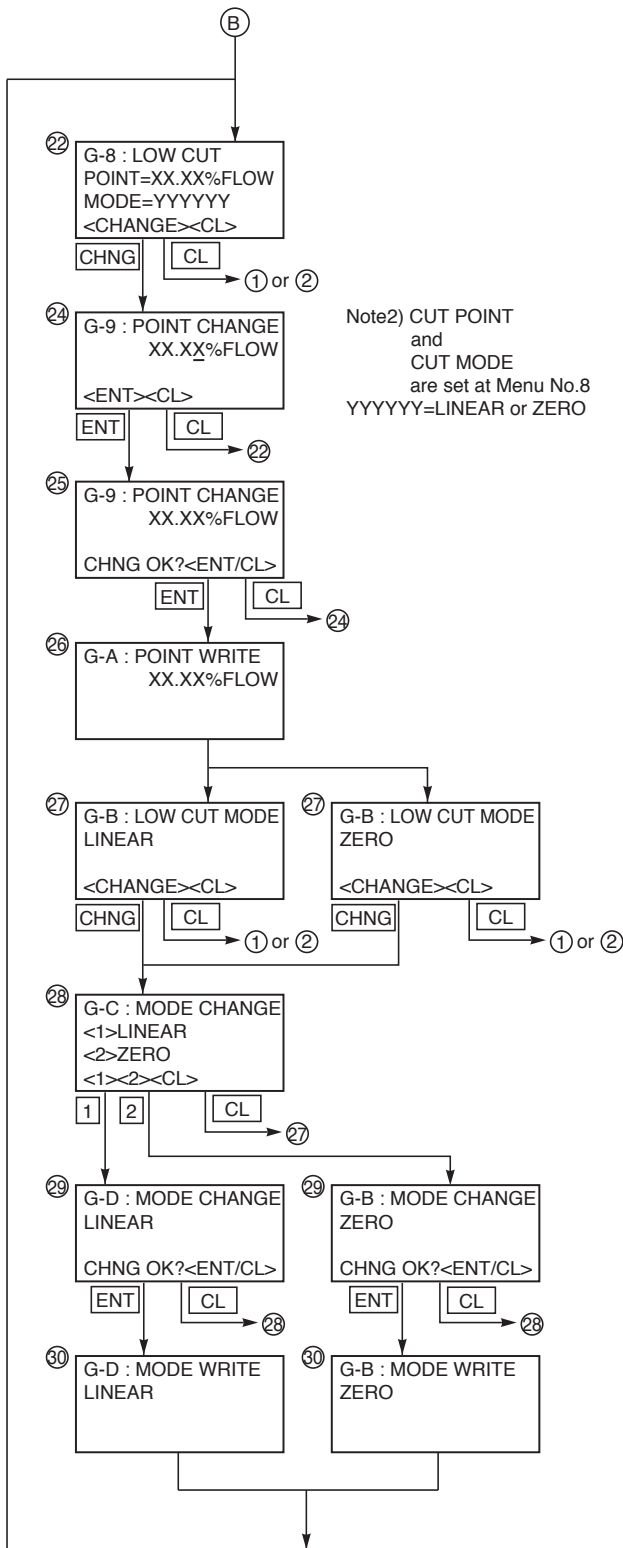

Low cut point setting for square root mode (flow measurement)

After choosing <2> on display ① (actual display if the flow mode is already activated) or <2> in display ④ (Flow mode chosen)

- Press <CHANGE> to set the low cut point. Cut point is adjustable within the range of 0.00 to 20.00 %.

Note :

If the cut point is set to small value around 0% even a minute differential pressure change causes a sudden output fluctuation. The cut point is used for improving the measurement in case of low flowrate.

• Press <ENT> to confirm otherwise press <CL> to cancel.

Low cut mode setting for square root mode (flow measurement)

After setting the low cut point, it is possible to set the low cut mode : Linear or Zero.

There are two modes :

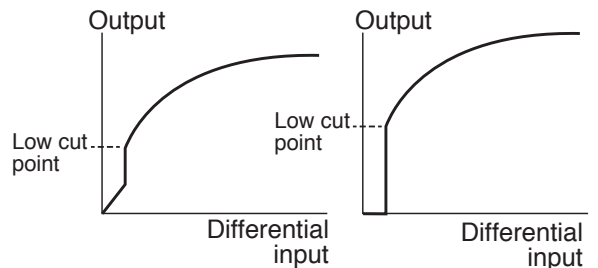

Fig. A: With linear output selected in low cut mode

Fig. B: With zero output selected in low cut mode

- Press <1> or <2> to set the cut point mode.
- Press <ENT> to confirm otherwise press <CL> to cancel.

Menu H : Linearization function

The linearization function is used for level measurement in open or closed tank.

This function can be used only if the tank shape cannot have linear link between the level and the fluid (for example : spherical tank or horizontal cylindrical tank...) 14 compensation points are available corresponding to 15 line segments, $(X_1, Y_1), (X_2, Y_2) \dots (X_{14}, Y_{14})$. Each compensation value between (X_n, Y_n) and (X_{n+1}, Y_{n+1}) is connected by first order approximate formula.

Functions for LINEARIZE are available for FXW Version 6.0 and upward.

- By pressing <INC> at display of ②, the display is shifted to the setting of LINEARIZE POINT ③.
- Press <CHNG> at display of ③ and input POINT XX to be compensated. Then press <ENT> and the display will be shifted to ⑤.
- Press <INC> at display of ⑤ and the display will be shifted to y for selection of <1> Lin. point: LP and <2> Comp. value : CV.
- Select <1> Lin. point : LP at display of 6 and input XXX.XX% to each point (LP1-LP□).
At the completion of input to all the compensated points, press ENT twice and the write of LP will be finished.
At this time, the display is shifted to ⑥.
Select <2> Comp. point : CV at display of ⑥ and input XXX.XX% to each point (CV1-CV□) in the same way as noted in <1> LP.
At the completion of input to all the compensated points, press ENT twice and the write of CV will be finished.
At the completion of write of compensated program for LP/CV, press CL twice at the display of ⑥ for shifting to ②.
- Then, press CHNG for selection of <1> INVALID and <2> EFFECTIVE of ⑰. At display of ⑰, press <2> and the display will be changed to EFFECTIVE.

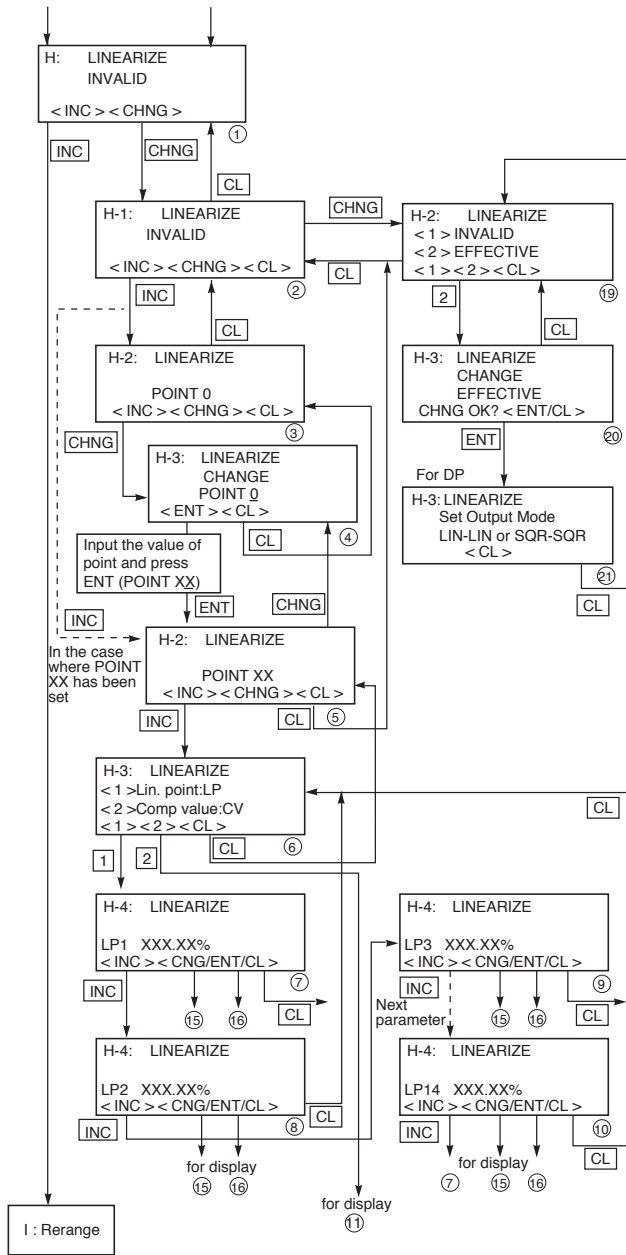

Note) In the key stroke for Linearization, please set each parameter in the below sequence.

1. Set the number of compensation points in the range of 2 to 14.
2. Set each linearization option point (LP*) correctly, and write them.
3. Set each compensation value (CV*) correctly, and write them.
4. Set linearization option into EFFECTIVE and write.

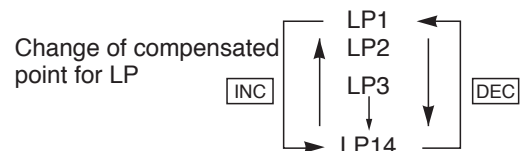

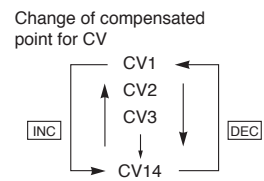
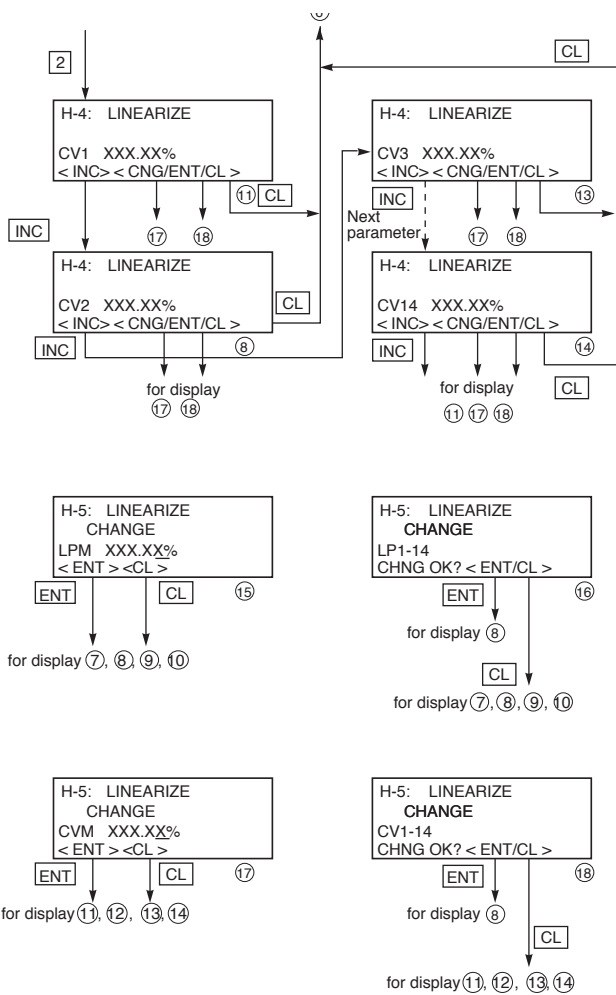

Important

When **<INC>** is pressed at display of ③, the following is displayed,

```
H-2: LINEARIZE
      POINT      0
      SETTING ERR <CL>
```

or

When **<ENT>** is pressed at display of ④, the following is displayed,

```
H-3: LINEARIZE
      POINT 15
      POINT SET
      SETTING ERR <CL>
```

To change according to following setting conditions
 POINT=2 ≤ (number of correction) ≤ 14
 setting err=00 or 01 or ≤ 15

When **<ENT>** is pressed at display of ⑮, the following is displayed,

```
H-5: LINEARIZE
      CHANGE
      LP□ 150.01%
      SETTING ERR <CL>
```

To change according to following setting conditions
 Requirement of setting
 Saturation current value (Lower limit) ≤ LP1 ≤ LP2...
 ≤ LP14 ≤ Saturation current value (Upper limit)

When **<ENT>** is pressed at display of ⑰, the following is displayed,

```
H-5: LINEARIZE
      CHANGE
      CV□ 100.01%
      SETTING ERR <CL>
```

To change according to following setting conditions
 -100% ≤ CV1, CV2...CV14 ≤ +100%

When **ENT** is pressed at display of ⑳, the following is displayed,

```
H-3: LINEARIZE
      Set LINEARIZE
      Point, LP and CV
      correctly. <CL>
```

Requirement of setting

1. $LP \leq LP2 \leq LP3 \dots LP8 \leq LP9 \dots LP13 \leq LP14$ (In the case that LP1-LP14=All Zero, it is inhibited to be set enable)
2. If $CVa \neq CVb$, then it must be $LPa < LPb$ (Note1)
3. If $LPa = LPb$, then it must be $CVa = CVb$ (Note1)
 Note1)
 a, b show next numeral such as
 $a=1 \ b=2$ or $a=2 \ b=3$ or $a=13 \ b=14$.
 or the following is displayed.

```
H-3: LINEARIZE
      Set OUTPUT MODE
      LIN-LIN or
      SQR-SQR <CL>
```

Before performing the LINEARIZE setting, set either of the following equations in the OUTPUT mode (Menu No.8) and XMTR DISPLAY (Menu No. G):

OUT = LIN SMTR DISP = LIN or
 OUT = SQR XMTR DISP = FLOW (Note 1)

Note 1)
 XMTR DISP = FLOW means the settings of % FLOW in % display or of FLOW units in actual scale display.

Menu I : Adjustment by LRV/URV range

The Rerange functionality can be used when zero adjustment (suppression or elevation) is necessary (for example : Level measurement).

Functions of RERANGE can be made with FXW Version 6.0 or upward.

When the lower range value (LRV) and upper range value (URV) need to be adjusted again during measurement of tank level, the measurement levels can be changed at the same time by setting the LRV with rerange.

LRV Rerange

Apply an input pressure required for rerange of LRV at display of ③ and press ENT twice.

In this way, the rerange of LRV is completed, then the new measurement range LRV and URV, which conforms to the actual input pressure, is displayed.

URV Rerange

Apply an input pressure required for rerange of URV at display of ⑥ and press ENT twice. The rerange of URV is completed, then the new measurement range LRV and URV corresponding to the actual input pressure is displayed.

Note) The unit of LRV/URV at ⑤ and ⑧ are displayed in the unit selected by Menu N° 4:UNIT.

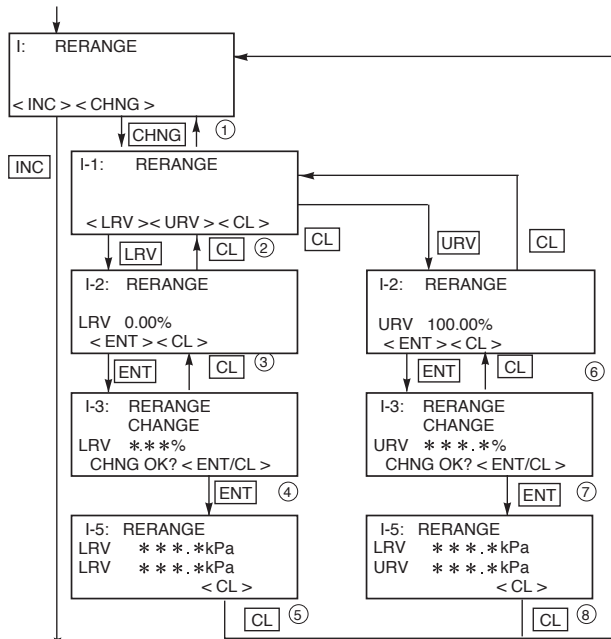

Menu J : SATURATE CUR



Important

Adjustment point setting condition

$-1.00\% \leq \text{LRV} \leq 100.00\%$

$0.00\% \leq \text{URV} \leq \text{Saturation current value (upper limit)}$

In the case that point is out of setting limit.

(Ex)

```
1-2:RERANGE
LRV    100.01%
SETTING ERR  <CL>
```

- In case of the actual scale specification with a digital indicator provided, if the range is changed, indicator display might not match. So, setting is required again in response to the display in the digital indicator (G:XMTR DISPLAY).

- In case of the actual scale specification with an analog indicator provided, if the range is changed, the scale for indicator might not ensure exact reading.

- When CHNG is pressed at display ④ or ⑦, the following is displayed.

```
1-1:RERANGE
Can't proceed.
Set Linearize
invalid.      <CL>
```

This means that RERANGE can't be made because MENU N° H:LINEARIZE is set in EFFECTIVE.

In this case, press the CL key and set in INVALID on the panel of N° H:LINEARIZE.



CAUTION

This rerange function adjusts input and output by range change.

Upon implementation of rerange, the measurement range changes as follows :

If RERANGE → LRV is implemented :

➔ Measurement range (LRV and URV) changes. However, span remains unchanged.

If RERANGE → URV is implemented :

➔ Only URV (span) of measurement range changes. Zero POint (LRV) remains the same.

Menu J : Saturation current value and specification

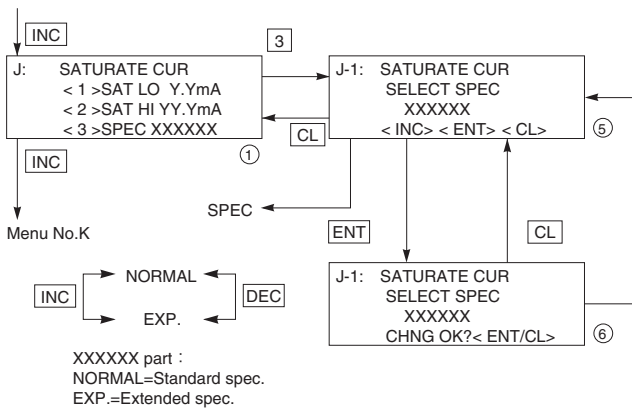
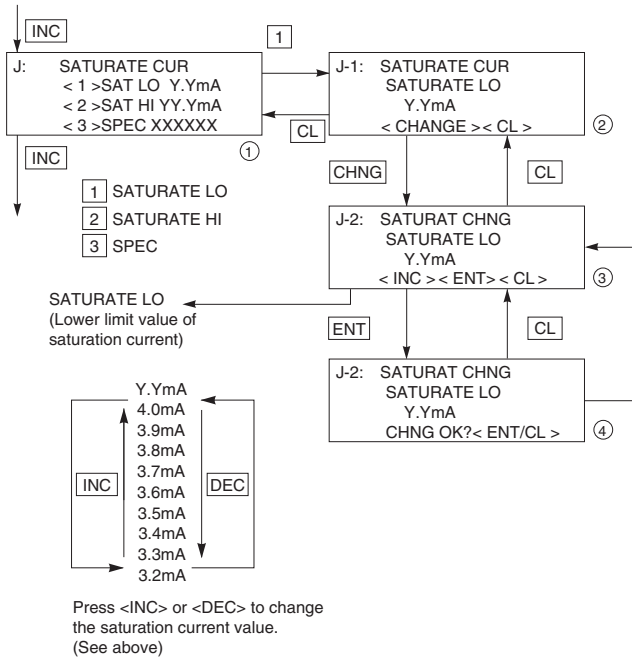

Saturation current value (Lower limit value=SAT LO, Upper limit value=SATO HI) and specification (SPEC NORMAL= Existing specification, SPEC EXP. = Extended specification) are settable.

Change of saturation current value (Lower limit) (Changeable only on "SPEC EXP")

- Press <1> for setting the current value for lower limit
 - Press <INC> or <DEC> to change the current value.
 - Press <ENT> to confirm otherwise press <CL> to cancel
- $3.2\text{mA} \leq \text{Saturation current (Lower limit value)} \leq 4.0\text{mA}$, but above the burnout current (UNDER SCALE)

Change of saturation current value (Upper limit value)

Make a setting as same as the setting of the lower limit value by input **2** on display ①.

$20.0\text{mA} \leq \text{Saturation current (Upper limit value)} \leq 21.6\text{mA}$, but under the burnout current (OVER SCALE)

* Burnout current is settable according to "9. Burnout direction and value".

Display of the specification

Existing specification or enhanced specification is selectable.

Refer to "J-3" in "J. Saturation current value and specification" of a local configurator unit with LCD display for details.



Menu K : Protective function of set value (Write protect)

This function sets and cancels the write protect with a password.

The object of write protect are adjustment and setting parameters including adjustment of external adjustment screw.

After cancelling write protect, it will automatically return to write protect state.

When the write protect is ON by this function, the write protect can not be cancelled by 3-push button of local configurator unit with LCD display.

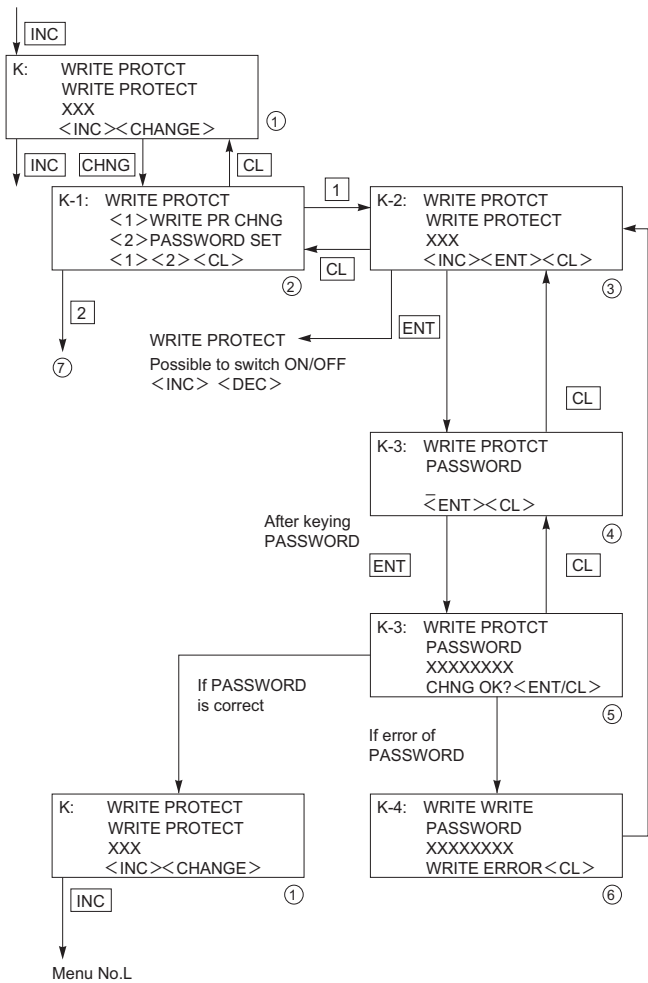

Write protect ON/OFF

- Press <1> on display ② for lock or unlock the transmitter.
- Press <INC> to choose OFF or ON
- Enter the password to confirme. If the password is correct, the setting/canceling information of write protect is saved.

Password setting

- Press <2> on display ②
- Insert on display ⑦ the old password then press <ENT>
- Insert the new password on display ⑧ then press <ENT>

The paswword can be set for numbers, letters : 8 characters maxi.

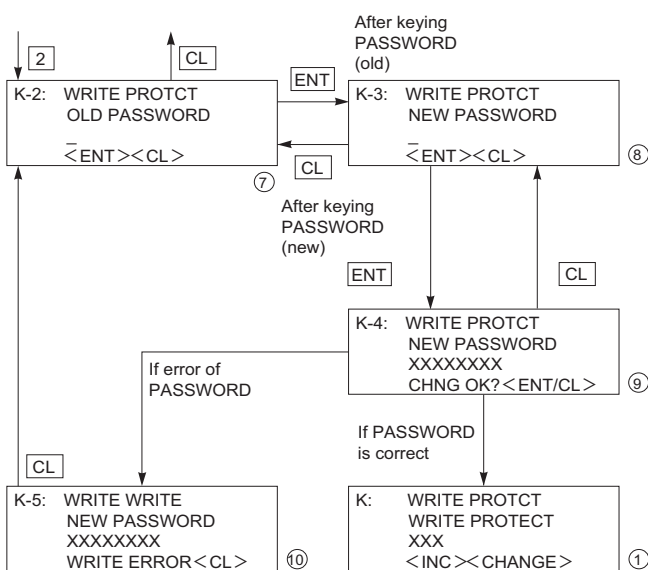

Menu L : Historical data

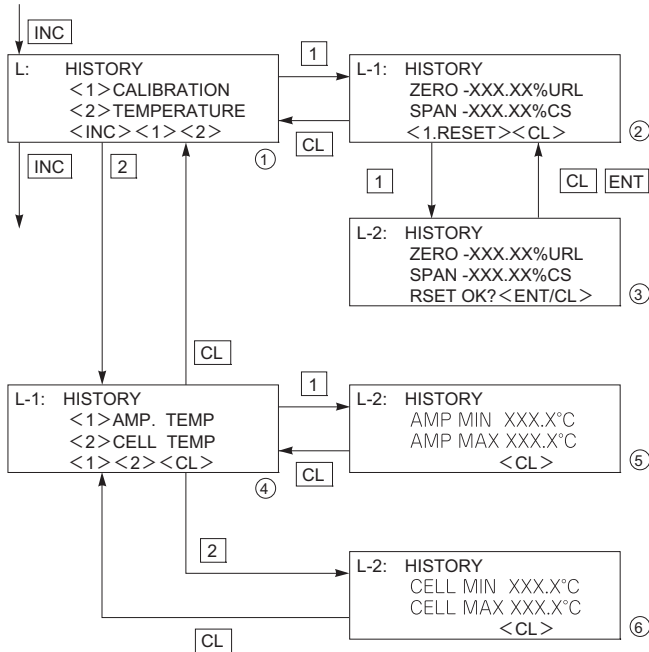

Display of ZERO/SPAN

- It is displayed by selecting <1> on the display ① .
ZERO means ZERO calibration value (4mA).
SPAN means SPAN calibration value (20 mA).
- Clear of ZERO/SPAN calibration data for users
It is cleared by selecting <1> on the display ② .

Display of amplifier and cell temperature.

- Press <1> on display ④ for MIN/MAX amplifier temperature
- Press <2> on display ④ for MIN/MAX cell temperature

No maintenance of transmitter is necessary.

According to the application conditions and the measured process, a periodic check of the output signal of the transmitter has to be done by skilled people (suggested period 36 months).

7.1 The following verifications are suggested by the manufacturer :

Check for tightness of the transmitter and the process connections as often as required.

Visual inspection

Visually inspect each part of the transmitter for damage, corrosion, etc.

Check and if possible clean all wetted parts of the transmitter to make sure the chemical resistance of the wetted parts. In case of corrosion, find out the reasons and replace or adapt the concerned parts.

Please follow the replacement procedure of the measuring cell described later.

Visual inspection of the transmitter for damage, corrosion etc...

Protect or replace the transmitter if necessary.

Covers and terminal O-ring

FCX transmitters are designed to be water and dust-proof. Make sure the O-ring of the housing covers are not damaged

Check that no foreign matters are stuck on the cover treads and grease them before remounting

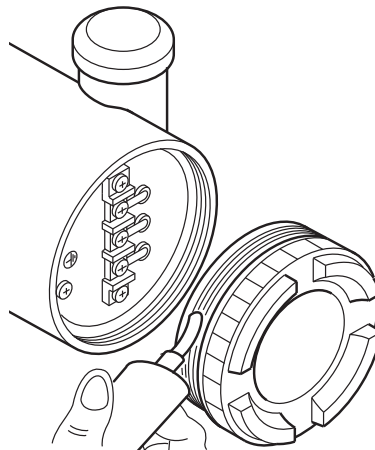

Piping leakage check

Using soapy water or the like, check the all process connections for leakage of process fluid.

If necessary, drain the moisture which has accumulated in the transmitter and process pipe. housing covers are not damaged

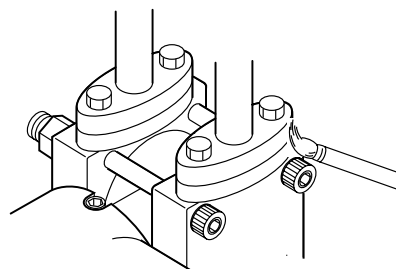

7.2 Troubleshooting

If troubleshooting, check the fault by using the Hand Held Communicator (HHC) with function "SELF CHECK" - Refer the chapter " Operation" in this manual.

The transmitter is supplied with the burnout adjusted : "fixed" output signal in case of failure. If an abnormality occurs in the process or transmitter, action should be taken with references to the table below:

Symptom	Cause	Remedy
Output current overshoots scale (The value is more than the upper limit of the saturation current.)	(1) The manifold valve does not open/close normally.	→ Repair the valve so that it opens/closes normally.
	(2) Pressure leak is occurring.	→ Repair leak.
	(3) Process piping is improper.	→ Make correct piping.
	(4) Process pipe is clogged.	→ Eliminate the cause of clogging.
	(5) Power supply voltage and/or load resistance is improper.	→ Make arrangement to obtain proper values.
	(6) Voltage between the external connection terminals of amplifier unit is wrong.	→ Check for faulty cable, insulation, etc. and repair as needed.
	(7) Zero and span or fixed output current(4, 20mA) are not adjusted.	→ Readjust according to chapter 6.
	(8) Electronic unit is faulty.	→ Replace the amplifier unit according to chapter 7.3.
No output current (The value is less than the lower limit of the saturation current).	(1) Same as (1) to (4) above	
	(2) Power supply polarity is wrong.	→ Correct wiring according to chapter 4.1.
	(3) Power supply voltage is improper.	→ Make arrangement to obtain proper values.
	(4) Voltage between the external connection terminals is wrong.	→ Check for faulty cable, insulation, etc. and repair as needed.
	(5) Zero and span or fixed output current(4, 20mA) are not adjusted.	→ Read just according to chapter 6.
	(6) Amplifier unit is faulty.	→ Replace the amplifier unit according to chapter 7.3.
Output current error.	(1) Process piping is improper.	→ Correct the piping.
	(2) Gas or solution is mixed in.	→ Vent or drain the transmitter.
	(3) Liquid density changes.	→ Perform density compensation.
	(4) Ambient temperature changes widely.	→ Minimize the temperature change.
	(5) Zero, span or fixed output current (4, 20mA) has deviated.	→ Readjust according to chapter 6.
	(6) Amplifier unit is faulty.	→ Replace the amplifier unit according to chapter 7.3.
When the indicator is abnormal.	(1) An error display is appeared.	→ Refer to "Contents of message"

If remedy is impossible, contact Fuji Electric's service department.

7.3 Replacement of defective parts

It's necessary to use new spare parts, please contact Fuji Electric france for this.

If the transmitter requires a replacement part, drain process fluid from the transmitter, Disconnect the transmitter and bring it into the instrumentation workshop.



DANGER

When removing an explosion-proof transmitter, turn OFF the main power, then disconnect the piping and wiring. Do not remove it when the power is ON to prevent serious accident such as explosion, fire, etc...

Identification of faulty parts

The main parts of the transmitter are the amplifier unit and the measuring cell.

Replace first the amplifier unit to find out if the failure reason comes from the amplifier unit or the measuring cell. Run the function "Self Check" with the HHC to find out the faulty part. When the failure is detected, please replace the concerned part.

Replacement of amplifier unit

- (1) Turn off the power supply.
- (2) Remove the indicator.
- (3) Remove the amplifier unit.
- (4) Unplug each connector carefully.
- (5) Assemble a new amplifier unit in the electronics housing and connect the connectors.

Assemble all parts in the reversing way than described before.

Check all the screws are correctly tightened, and screw the electronics housing cover on the transmitter

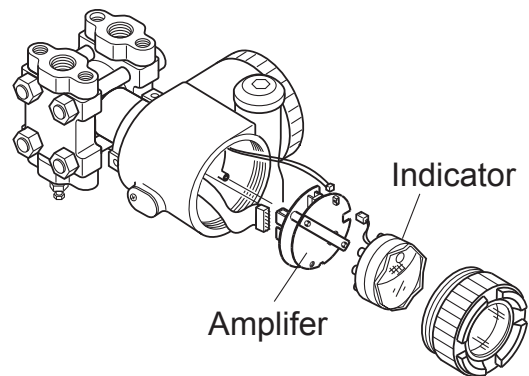

PROHIBITION

When installing the electronics unit, make sure that the zero adjust screw end is in front of the groove in the amplifier unit.

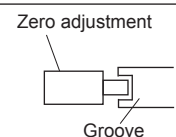

PROHIBITION

The electronics unit should be removed carefully so as not to damage the internal wiring.

- (6) After completion of replacement, perform zero and span adjustments.

Replacement of detecting unit

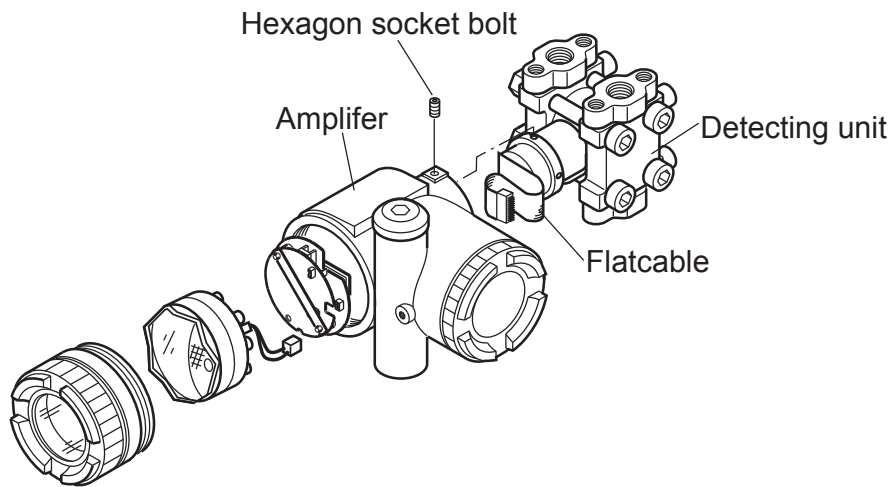

- (1) Remove the electronics unit according to "Replacement of electronics unit"
- (2) Remove the 2 hexagon socket bolts from the electronic housing.
Pull the electronics housing straight forward and away from the detecting unit.
- (3) Replace the detecting unit with a new one of the same type.
- (4) Check if the O-ring of the cell neck and all the surfaces in contact between the electronics housing and the cell neck not damaged. Assemble measuring cell and electronics housing.
Tighten the 2 screws
- (5) Connect each connector of the electronics unit and attach it to the amplifier unit.
- (6) After connecting all the connectors, assemble the amplifier unit in the electronics housing.
- (7) After assembly, perform zero and span adjustment

PROHIBITION

- Ensure that replacement detector unit has the same specification as the original by comparing nameplates.
- When removing the transmitter case, pay attention not to damage the flatcable connected to the amplifier unit.

Replacement of the internal parts of detecting unit

In case of differential and flow transmitter (code symbol: FKC)

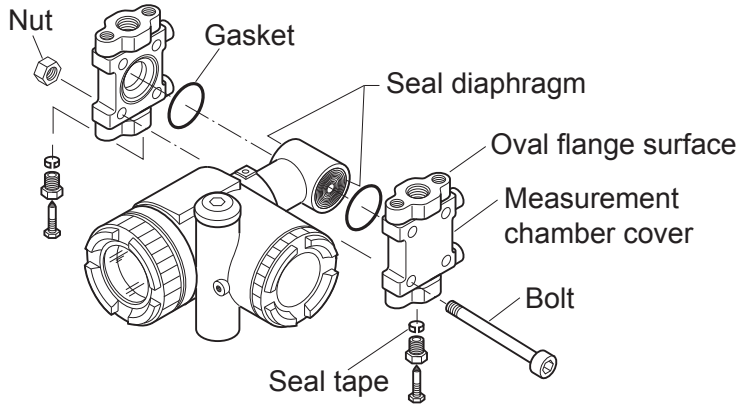

- (1) Remove the 4 hexagon socket head bolts.
- (2) The process covers, the O-ring and the bolts and nuts can now be removed.
- (3) After disassembly, replace the faulty part with a new ones.
- (4) Before reassembling, clean carefully the O ring groove of the process cover with a soft cloth immersed with water, alcohol, Freon TF or similar.
- (5) Reassemble the detecting unit by reversing the disassembling procedure.

Please check the correct position of the process covers to avoid that the diaphragms of the measuring cell are damaged. The torque for the bolts of the process covers are indicated in the following table.

Bolt size	Bolt material	Tightening torque	Maximum working pressure
M10	Cr-Mo steel	50 N.m	420 bar
M10	SUS 316	40 N.m	100 bar
M10	SUS 630	50 N.m	420 bar
M12	Cr-Mo steel	60 N.m	420 bar
M12	SUS 660	60 N.m	420 bar
M16	SUS 660	110 N.m	500 bar
M20	SUS 660	260 N.m	1035 bar

- (6) After assembly, carry out a pressure test. Apply a pressure equal to 150% of the maximum working pressure to both high pressure (H) and low pressure (L) measurement chambers of the transmitter simultaneously during 15 minutes, and make sure that there is no leakage.



To avoid any damage of the measuring cell, do not exceed the test pressure of the different cells (please refer to the technical datasheets of the concerned transmitter)



In case of absolute and gauge pressure transmitter (FKA and FKG)

- (1) Remove the 4 hexagon sockets head bolts
- (2) The process covers, the O-ring and the bolts and nuts can now be removed
- (3) After disassembly, replace the faulty part with a new one
- (4) Before reassembly, clean carefully the O-ring face of casing cover with the soft cloth immersed in water, alcohol, or similar
- (5) Reassemble the detecting unit by reversing the disassembling procedure.

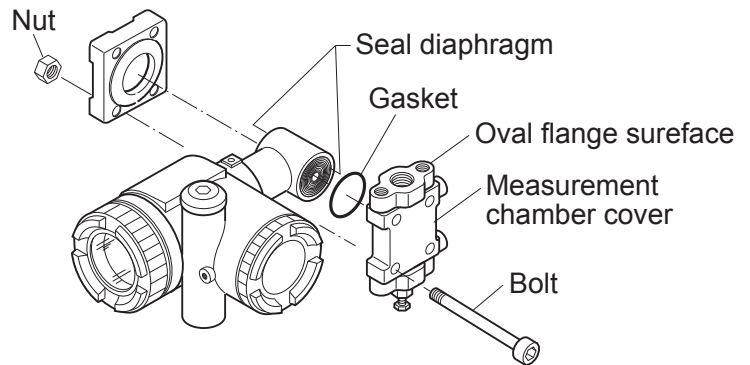

The torque of the bolts of the process covers are indicated in the following table :

Absolute pressure transmitter FKA :

Bolt size	Bolt material	Tightening torque	Maximum working pressure
M10	Cr-Mo steel	50 N.m	30 bar
M10	SS 316	30 N.m	30 bar
M10	SS 630	50 N.m	30 bar

Gauge pressure transmitter FKG :

Bolt size	Bolt material	Tightening torque	Maximum working pressure
M10	Cr-Mo steel	50 N.m	500 bar
M10	SS 316	30 N.m	100 bar
M12	Cr-Mo steel	60 N.m	500 bar
M12	SS 660	60 N.m	500 bar
M16	SS 660	110 N.m	500 bar

- (6) After assembly, carry out a pressure test. Apply a pressure equal to 150% of the maximum working pressure to both flange side, high pressure side (HP) and low pressure (LP) measurement chamber of the transmitter simultaneously during 15 minutes, and make sure there is no leakage.

 Caution Remember !	To avoid any damage of the measuring cell, do not exceed the test pressure of the different cells (please refer to the technical datasheets of the concerned transmitter)
--	---

In case of level transmitter (FKE)

- (1) Remove four hexagon socket head bolts with a torque wrench, etc..
- (2) The process covers, the O-ring and the bolts and nuts can now be removed
- (3) After disassembly, replace the faulty part with a new one.
- (4) Before reassembly, clean carefully the O-ring face of casing cover with the soft cloth immersed in water, alcohol, Freon TF or similar.

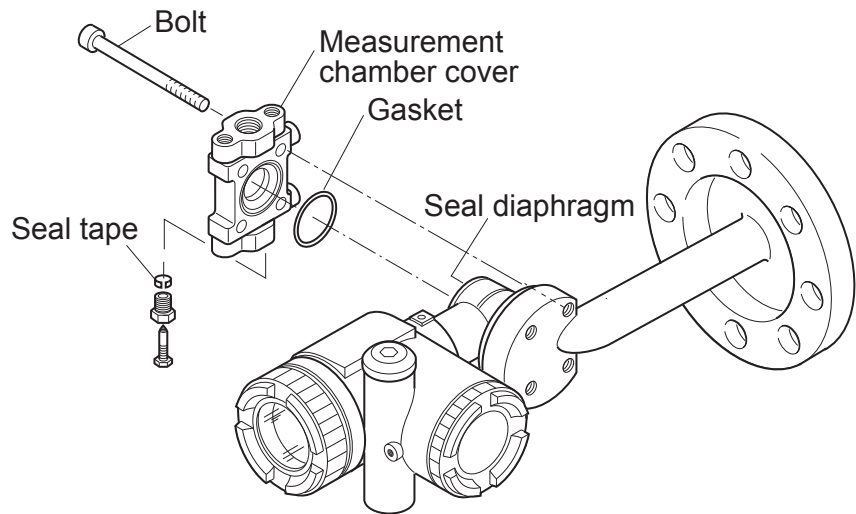

- (5) Reassemble the detecting unit by reversing the disassembling procedure.

The torque of the bolts of the process covers are indicated in the following table.

Bolt size	Bolt material	Tightening torque	Maximum working pressure
M10	Cr-Mo steel	50 N.m	Up to rated flange pressure
M10	SS 316	30 N.m	Up to rated flange pressure
M10	SS 630	50 N.m	Up to rated flange pressure

- (6) After assembly, carry out a pressure test. Apply a pressure equal to 150% of the maximum working pressure to both flange side, high pressure side (HP) and low pressure (L) measurement chamber of the transmitter simultaneously during 15 minutes, and make sure there is no leakage.



To avoid any damage of the measuring cell, do not exceed the test pressure of different cells (please refer to the technical datasheets of the concern transmitter)

Replacement of the analog indicator

- (1) Unscrew the electronics housing cover on indicator side.
- (2) Remove the analog indicator.
- (3) Pull out the connector extending from the analog indicator.
- (4) Connect the connector of a new analog indicator to the electronics section. (See the figure below.)
- (5) Mount the analog indicator by reversing the disassembling procedure.
- (6) Assemble the electronics housing cover.

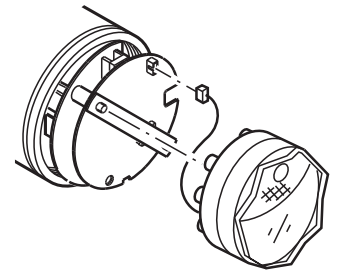
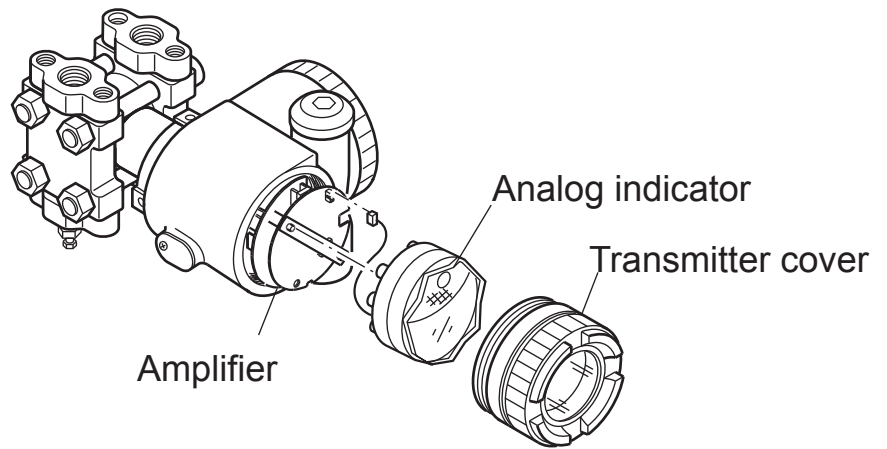

Replacement of the digital indicator

- (1) Unscrew the electronics housing cover on indicator side.
- (2) Remove the 2 fixing screws.
- (3) Remove the connector pin connecting the digital indicator and the amplifier unit. However, if you replace only the digital indicator, you need not remove the connector pin.
- (4) Connect a new digital indicator following the reverse order of disassembly procedure.

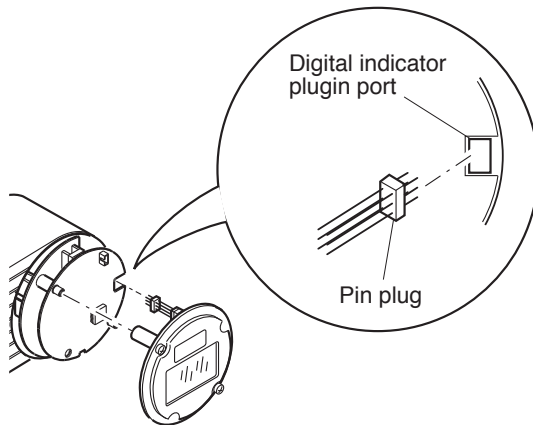
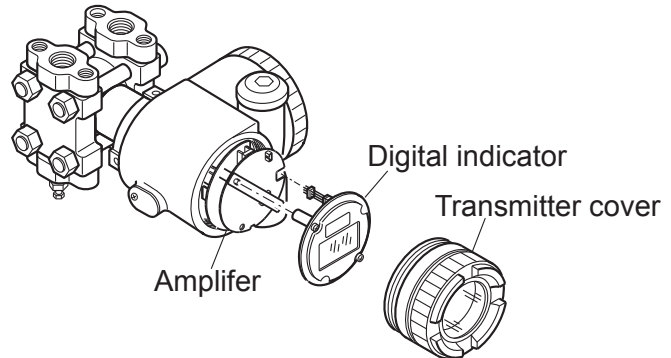

- (5) Fasten the digital indicator to the electronics section by tightening 2 fixing screws.

Before tightening, make sure a small recess on the surface is positioned at the top as shown below.

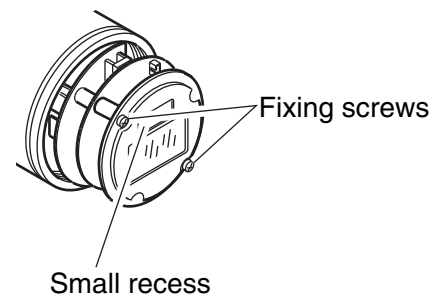

- (6) Assemble the electronics housing cover.

7.4 Adjustment after replacement of the amplifier unit or the measuring cell

Adjustment

After completion of the assembly work mentioned above, use the following procedures for adjustment and setting. Adjustment should be performed using the HHC.

(1) After replacement of electronics unit (including replacement of internal parts)

No.	Item	Display symbol of local configurator unit with LCD display (Relevant page)	Display symbol of HCC (Relevant page)	Contents of setting adjustment
1	TAG No.	1: TAG (P44)	1: TAG No. (P73)	Set the previous data before replacement of amp unit.
2	Model code	2: TYPE (P45)	2: TYPE (P73)	Set the previous data before replacement of amp unit.
3	Serial No.	3-1: SERIAL No. 3-2: VER (P46)	3: SERIAL No. (P74)	Not necessary for operation
4	Engineering unit	4: UNIT (P47)	4: UNIT (P74)	Set the previous data before replacement of amp unit.
5	Range limit	5: URL (P47)	5: RANGE LIMIT (P75)	Not necessary for operation
6	Measuring range	6-1: LRV 6-2: URV (P48)	6: RANGE (P75)	Set the previous data before replacement of amp unit.
7	Damping	7: DAMP (P50)	7: DAMPING (P76)	Set the previous data before replacement of amp unit.
8	Output mode	8-1: OUT Md 8-2: CUT Pt 8-3: CUT Md (P51)	8: OUTPUT MODE (P77)	Set the previous data before replacement of amp unit.
9	Burnout direction	9-1: BURNOUT 9-2: OVER 9-3: UNDER (P53)	9: BURNOUT (P78)	Set the previous data before replacement of amp unit.
10	Zero/span calibration	A-1: ZERO A-2: SPAN (P55)	A: CALIBRATE (P879)	Implement span calibration after zero calibration.
11	Calibration output circuit	b-1: 4mAAdj b-2: 20mAAdj b-3: FIXcur (P57)	B: OUTPUT ADJ (P80)	Loop check & calibrate fixed output current (4mA,20mA)
12	Measurement data	(Normal mode)	C:DATA (P81)	Check the measurement data.
13	Self-diagnosis	d1: AMPTMP d2: ALMCHK (P58)	D: SELF CHECK (P81)	Check, if it is necessary.
14	Printer function	-	E: PRINT (P82)	In case of HHC with printer option, print if it is necessary.
15	Lock of adjustment functions	F: LOCK (P59)	F: XMTR EXT.SW (P82)	Set the previous data before replacement of amp unit
16	Indication of digital indicator	G-1: LDV G-2: UDV G-3: DP G-4: LcdUnit G-5: LcdOpt (P60)	G: XMTR DISPLAY (P83)	Set the previous data before replacement of amp unit.
17	Programmable linearization function	-	H: LINEARIZE (P86)	Set the previous data before replacement of amp unit.
18	Input-output range adjustment	I-1: LRVAAdj I-2: URVAAdj (P63)	I: RERANGE (P88)	Adjust the input-output range (RERANGE) as required.
19	Change of saturation current	J-1: SAT LO J-2: SAT HI J-3: SPEC (P65)	J: SATURE CUR (P89)	Set the previous data before replacement of amp unit.
20	Protective function of set value	K: GUARD (P67)	K: WRITE PROTCT (P90)	Set the previous data before replacement of amp unit.
21	History information	L-1: His ZERO L-2: His SPAN L-3: His CLEAR L-4: His AMP L-5: His CELL (P68)	L: WRITE PROTCT (P91)	Check data as necessary

(2) After replacement of detecting unit (including replacement of internal parts)

1	Zero/span calibration	A-1: ZERO A-2: SPAN (P55)	A: CALIBRATE (P79)	Implement span calibration after zero calibration
---	-----------------------	------------------------------	--------------------	---

A1 BUILT-IN ARRESTER

An arrester is used to protect a transmitter or receiver from an abnormal voltage such as lightning surges induced into signal lines. A built-in type arrester is mounted in the terminal unit. A nameplate marked “**with arrester**” is attached to the terminal unit of transmitter.

Installation

If surges are likely to appear on the loop 4-20 mA, for example because of lightning, it is advisable to install a built-in arrester should be used in combination with panel mounting type arrester (type PXC) for distributor protection

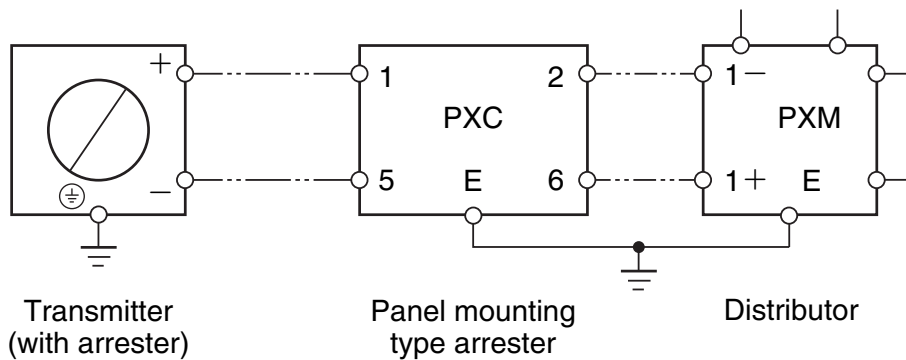

Grounding

Since transmitter and arrester groundings are internally connected together, user have only to connect the external grounding terminals to ground. Grounding terminal must be used, in case of the explosion proof or intrinsic safety type transmitter.

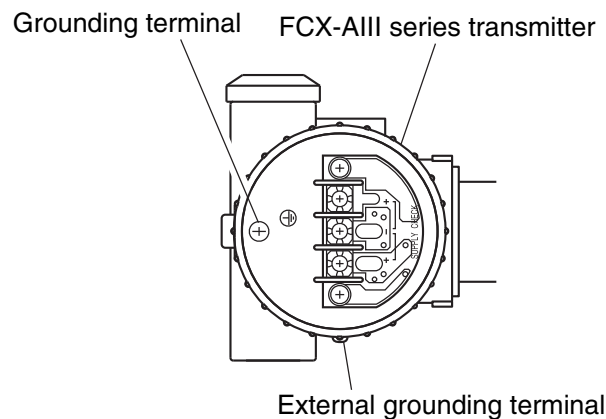

 INDICATION	<p>Grounding resistor should be 100Ω. Avoid common grounding with a lightning rod. In case of a transmitter with arrester, maximum power supply is 32 V DC.</p>
--	---

Maintenance

Check of arrester :

Measure output current from the transmitter on the current loop 4/20mA and CK+/- of the transmitter.

If the measured two output current are the same, the arrester is normal.

In case the measured values have a difference of 0.1% (0.016mA) or more, the arrester is not functioning. In the above case, the arrester unit (terminal unit) should be replaced with a new one.

Limitation of insulation resistance and dielectric strength test

An insulation resistance and dielectric strength test should be avoided as a rule, since it may damage the arrester.

Output measurement at check terminals (CK+ and CK-)

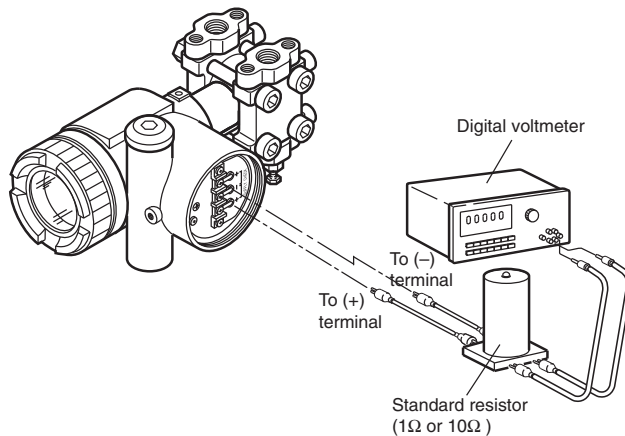

Output measurement on the current loop (4/20 mA)

* Disconnect the wire from the "-" terminal and connect the measurement device as shown below.

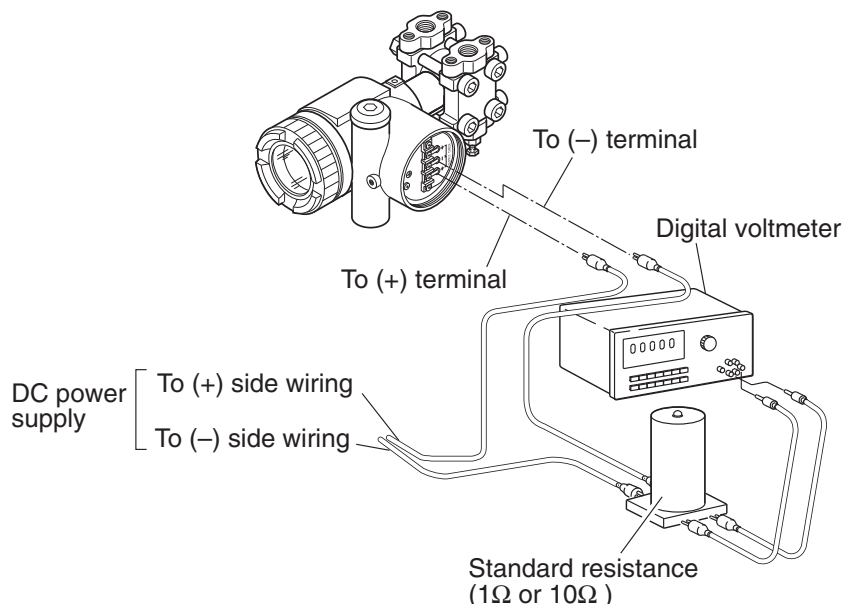

Preparation for calibration

The transmitter should be calibrated in a calibration room.
For calibration of each transmitter, the following devices are required.

- Pressure generator (should have as high an accuracy as possible 0,05% mini)
*Measurable ranges are listed in the table below.
- Power supply : DC power supply (24 V DC) or Fuji Electric FC series power supply unit
- Load resistor : Standard resistor 250 W (within $\pm 0.0125 \Omega$)
- Measuring device: Digital voltmeter (capable of measuring transmitter output with an accuracy better than 0.1%)
- Hand Held Communicator (HHC) type FXW

Measurable range

Differential pressure range

FKC model...kPa (mbar)
0,1~1 (1~10)
0,1~6 (1~60)
0,32~32 (3,2~320)
1,3~130 (13~1300)
5~500 (50~5000)
30~3000 (300~30000)
500~20000 (5000~200000)

Pressure range

FKG model...kPa (bar)
1,3~130 (0,013~1,3)
5~500 (0,05~5)
30~3000 (0,3~30)
100~10000 (1~100)
500~50000 (5~500)

Absolute range

FKA model...kPa abs.(bar abs.)
1,6~16 (0,016~0,16)
1,6~130 (0,016~1,3)
5~500 (0,05~5)
30~3000 (0,3~30)
100~10000 (1~100)

Differential pressure range with remote seals

FKD...F model kPa (mbar)
0,32~32 (3,2~320)
1,3~130 (13~1300)
5~500 (50~5000)
30~3000 (300~30000)
200~20000 (2000~200000)

Pressure range with remote seal

FKB...F model kPa (bar)
1,3~130 (0,013~1,3)
5~500 (0,05~5)
30~3000 (0,3~30)
100~10000 (1~100)
500~50000 (5~500)

Absolute pressure range with remote seal

FKM...F model kPa abs (bar abs)
1,6~16 (0,016~0,16)
1,3~130 (0,013~1,3)
5~500 (0,05~5)
30~3000 (0,3~30)
100~10000 (1~100)

Level pressure range

FKE...F model kPa (mbar)
0,1~6 (1~60)
0,32~32 (3,2~320)
1,3~130 (13~1300)
5~500 (50~5000)
30~3000 (300~30000)

Pressure range with direct mounting

FKP...F model kPa (mbar)
8,125~130 (81,25~1300)
31,25~500 (312,5~5000)
187,5~3000 (1875~30000)
625~10000 (6250~100000)

Pressure range with direct mounting

FKH model kPa (mbar)
8,125~130 (81,25~1300)
31,25~500 (312,5~5000)
187,5~3000 (1875~30000)

Calibration procedure

(1) Make wiring according to the diagram below

When current is measured with an amperemeter connected to CK+ and CK – terminals, the internal resistance of the amperemeter should be 12Ω or less.

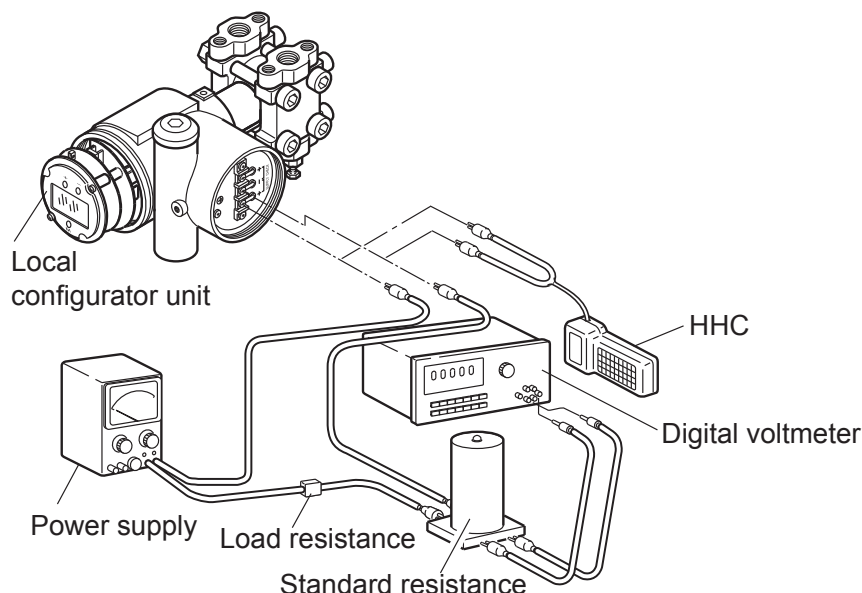

! INDICATION

For communicate correctly with the hand held communicator (HHC), a load resistor of 250Ω mini is required.

(2) Calibration of output circuit (D/A) :

This menu has to be used to change the output signal values corresponding to zero and 100% of the output signal. No pressure generator is required.

Local configurator with LCD display : Calibrate with reference to "Output circuit calibration" in "Adjustment" in Chapter 4 and HHC : Calibrate with reference to "Calibration of output circuit"

(3) Zero/span adjustment :

Local configurator with LCD display : Calibrate with reference to "Zero/span calibration" Adjustment with HHC : Calibrate with reference to "Zero/span adjustment"

(4) Accuracy test

Apply input pressures in the order of 0%, 25%, 50%, 75%, 100%, 75%, 50%, 25% and 0%, and read output at each input pressure.

Make sure the difference between each output value and input pressure (%) is within the accuracy rating listed in the table below.

The voltage values in the table are dependent on use of "DC power supply + standard resistor 250Ω + digital voltmeter (measuring device).

Measurement category	Reference value	Accuracy (according type)	
		Accuracy : 0,065%	Accuracy : 0,2%
Percent display % Current measurement (mA)	0, 25, 50, 75, 100 4, 8, 12, 16, 20	$\pm 0,065$ $\pm 0,0112$	$\pm 0,2$ $\pm 0,032$
Voltage measurement (V) on load resistor of 250Ω	1, 2, 3, 4, 5	$\pm 0,0028$	$\pm 0,008$

The damping value (time constant), function of zero/span adjust screw, output current mode, indicator scale, cut point, mode below cut point and burnout, have been set prior to delivery as shown in the following.

Each parameter is changed by using HHC or the 3 push button of the LCD display.

N°	Item	contents of parameter
1	Damping value (time constant)	0,06sec
2	External adjustment function of the transmitter	Adjustable (ENABLE)
3	Current output mode	Linear (Could be set in factory when ordering (note 2))
	Digital indicator scale (9th digit of code symbol)	Could be set in factory when ordering
4	Cut point (square root extraction mode setting)	7.07%
5	Mode below cut point (square root setting)	Linear
6	Burnout	Hold (note 3)
7	Polygonal line correction	Not corrected (INVALID)
8	Saturation current	Normal specification (NORMAL)
9	Protective function of set value (write protect)	Canceled (OFF)

Note 1) Use the HHC or the local configurator unit with LCD display to change the setting of all the items except "7: Polygonal line correction," which can be changed only by the HHC.

Note 2) In both the differential pressure transmitter (Type: FKC) and remote seal type (Type: FKD), the output current mode is set in linear unless it is designated.

Note 3) "Hold" is selected for "Burnout" unless otherwise specified by the order.

1. HART[®] communication function

1.1 HART[®] communication

The FCX-All V5 smart type transmitters are used for communication with Fuji HHC (Handheld Communicator) or HART[®] ¹⁾ master device such as HART[®] communicator. For details, refer to the instruction manual for HART[®] master device.

Note1)

HART[®] (Highway Addressable Remote Transducer) is a trademark of Rosemount Inc.

1.2 HART[®] Universal Handheld communicator

The HART[®] universal handheld communicator (hereinafter referred to as HART[®]) is a communicator capable of using for communication with various type of HART[®] field devices. A user in possession of HART[®] master device is ready for communication with the FCX-All V5 transmitters. For details, refer to the instruction manual for HART[®] communicator.

1.3 DD (Device Description)

Device Description (DD) is a program to pick up features of a field device having HART[®] communication functions. By saving DD in the memory of HART[®] communicator, the functions of each field device can be used for communication.

Even when FCX-All series / FCX-All V5 series DD is not saved in the memory of HART[®] communicator, it can be used in Generic mode ²⁾.

For details, refer to the instruction manual for HART[®] communicator.

Note2) The Generic mode is used to start communication when a field device DD is not installed in HART[®] communicator. In this mode, functions which can be used are limited to general-use functions.

2. Connection

Connection of HART® communicator

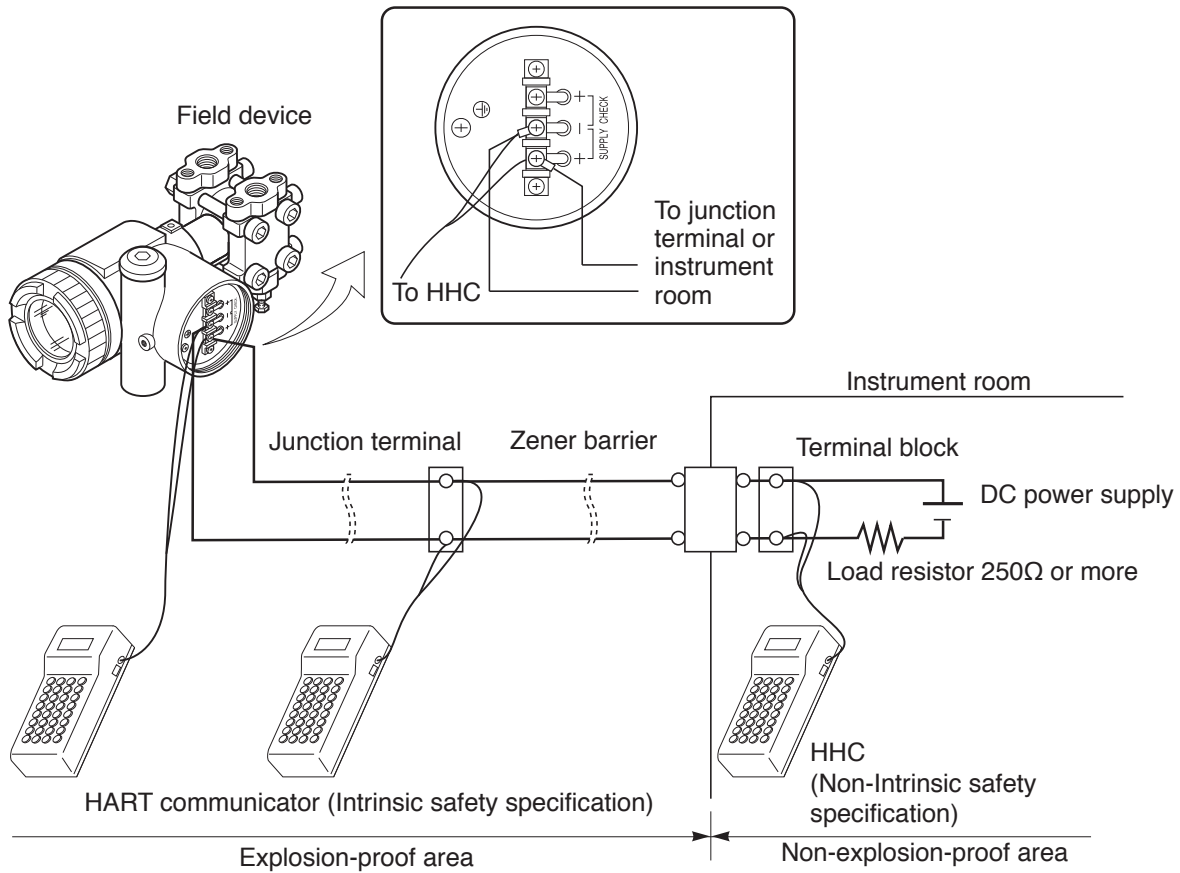

! INDICATION

Fuji HHC and HART® communicator can not be used at the same time. Be sure to connect individually.

! INDICATION

When using Fuji HCC and HART communicator alternately, turn OFF the power for the communicator after changing from one to another, then restart the communication. At this time, old data may be left in the communicator.

⚠ DANGER

In the case of a flameproof transmitter, the HHC can only be connected via the junction box located outside the hazardous area.

3. Function and operation (example)

3.1 HART® Communicator Menu Tree

3.1.1 Menu Tree 1 - Generic -

Example on HC-475 Hand Held Communicator

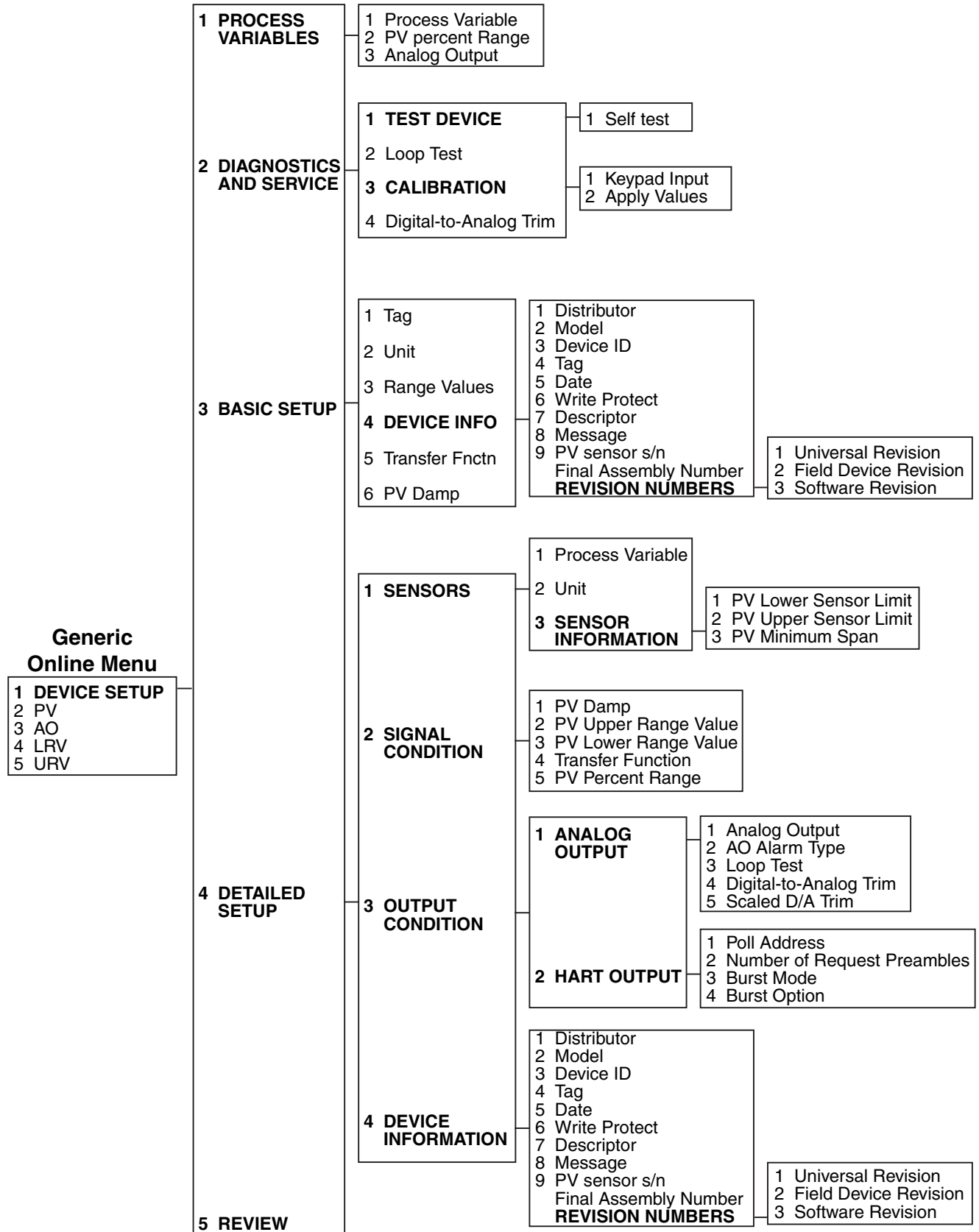

3.1.2 Menu Tree 2 - Use of DD for FCX-All series transmitters -

Example on HC-475 Hand Held Communicator

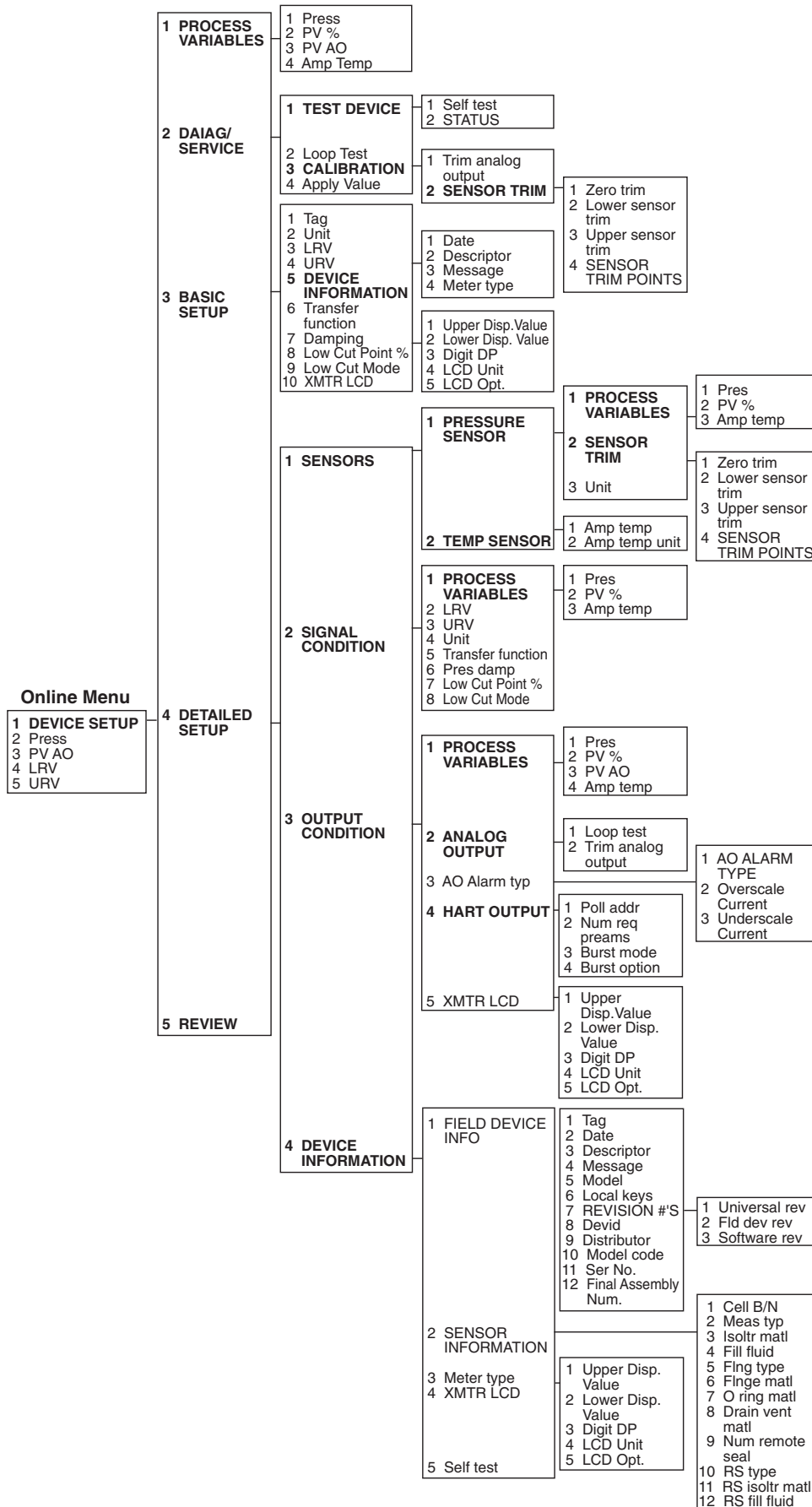

For more details about these parts, please contact Fuji Electric France.

BLOCK A Amplifier assembly

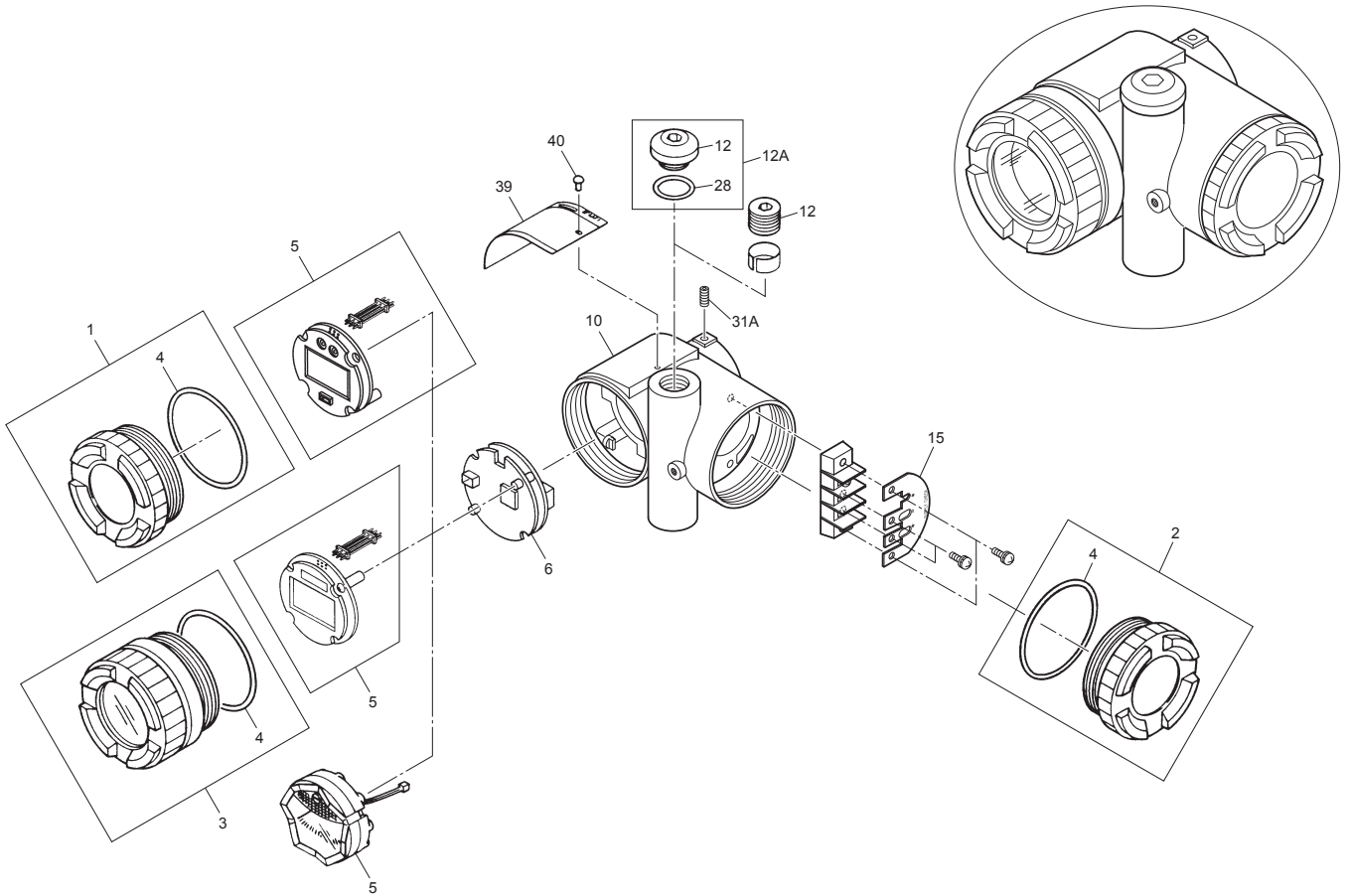

BLOCK B : FKC Differential pressure (flow) transmitter detector ass'y

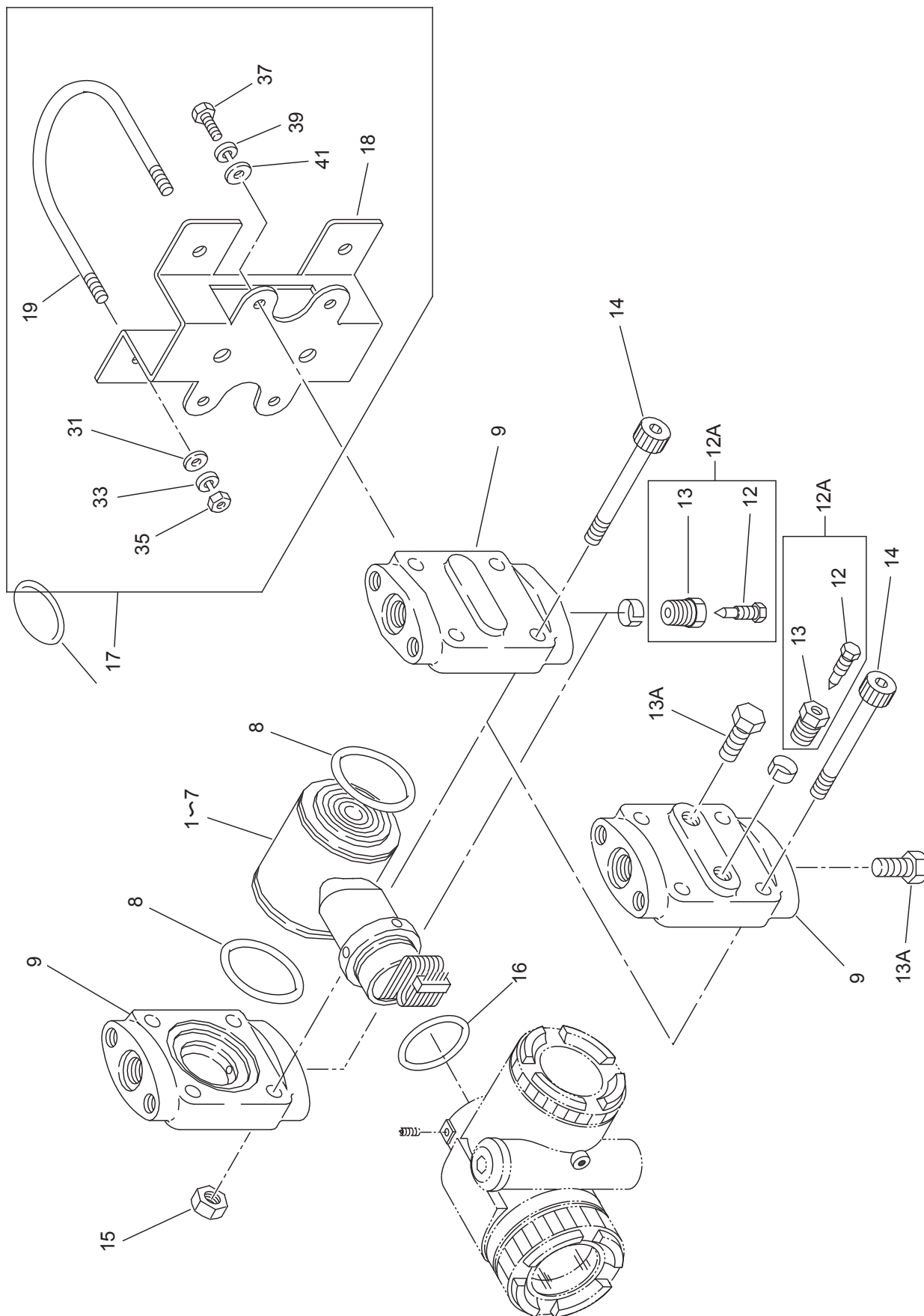

BLOCK C & D : FKG & FKA

Pressure and Gauge transmitter detector ass'y

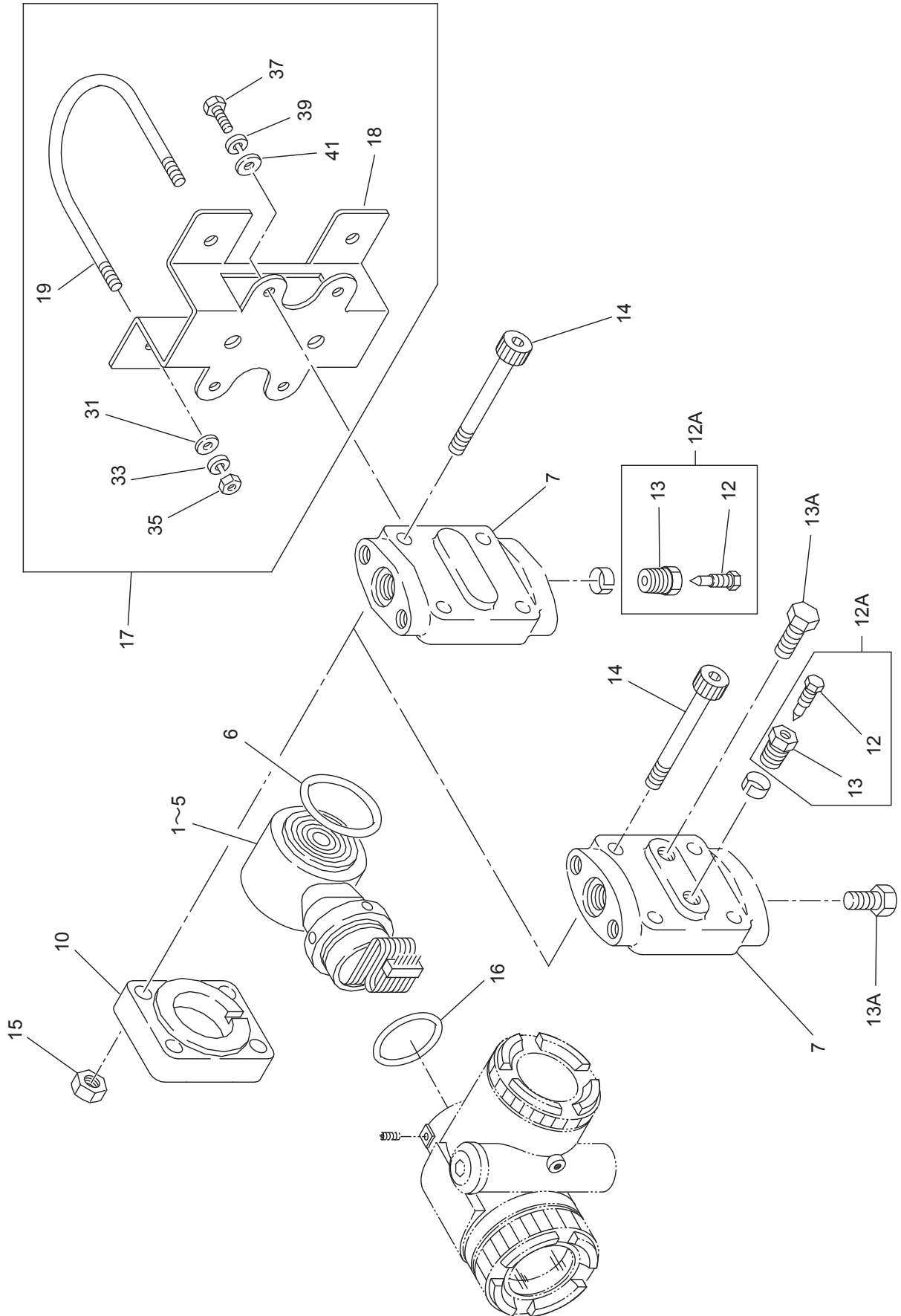

BLOCK P : FKP & FKH
direct mount type

Gauge and Absolute pressure transmitter detector ass'y ...

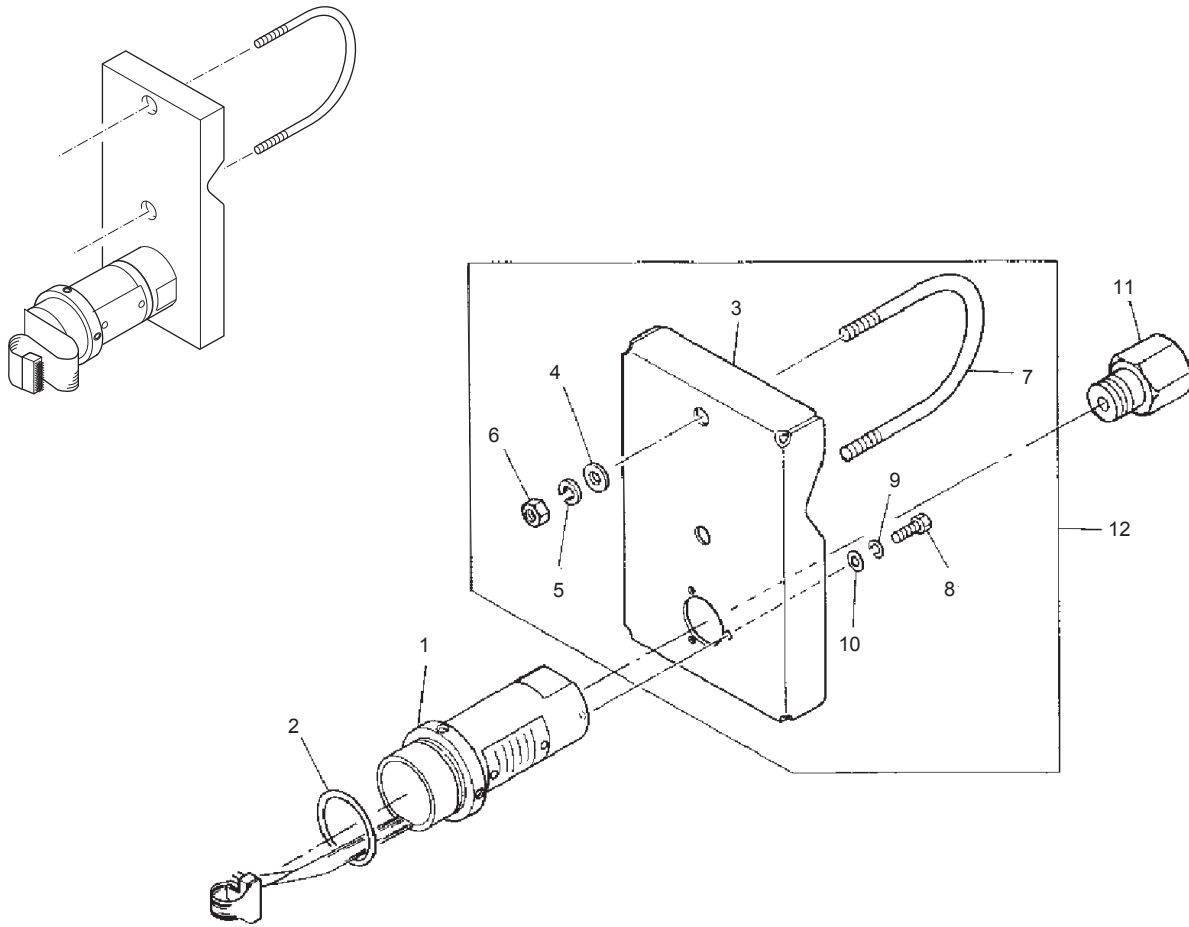





Fuji Electric France S.A.S.

46 rue Georges Besse - ZI du brézet - 63039 Clermont ferrand

Tél : 04 73 98 26 98 - Fax : 04 73 98 26 99

Mail : sales.dpt@fujielectric.fr - web : www.fujielectric.fr

Fuji Electric can accept no responsibility for possible errors in catalogues, brochures and other printed material. Fuji Electric reserves the right to alter its products without notice. This also applies to products already on order provided that such alterations can be made without subsequential changes being necessary in specifications already agreed. All trademarks in this material are property of the respective companies. All rights reserved.
