

ZFDM-4 DUST MONITOR

INSTRUCTIONS FOR ASSEMBLY, ADJUSTMENT, MAINTENANCE

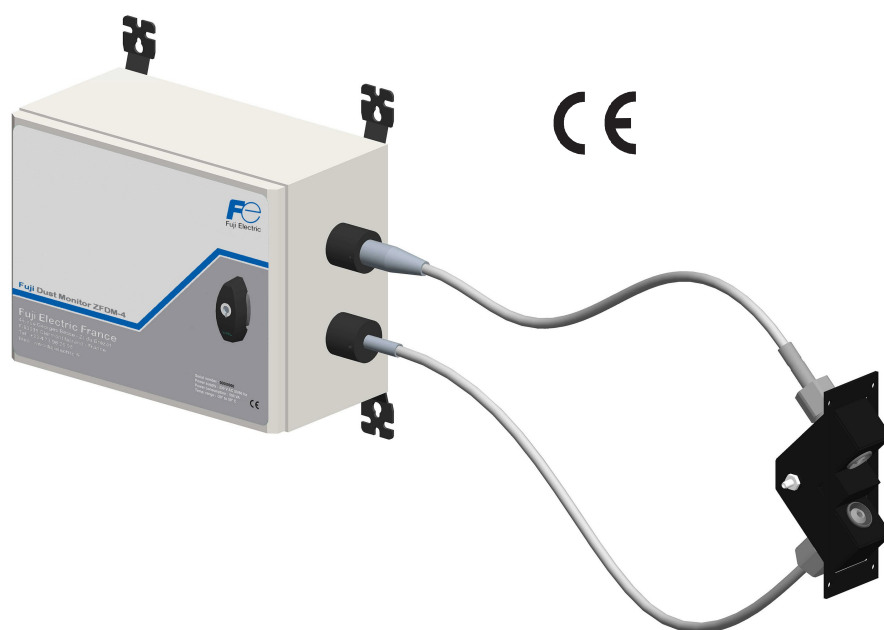

SUMMARY

1 - PRESENTATION	5
1.1 - General Technical Specifications	5
1.2 - Description of the electronic circuits	6
1.2.1 - Main Circuit	6
1.2.2 - Transmitter/Receiver unit	7
2 – OPERATING PRINCIPLES FOR THE ZFDM-4 DUST MONOTOR.....	8
2.1- Measuring principle	8
2.2 - Calibration principle	8
2.3 - Principle of monitoring fouling	10
3 - INSTALLATION OF THE ZFDM-4 DUST MONOTOR.....	12
3.1 - Fitting the sensor in the duct	12
3.2 - Installing the electric panel	14
3.2.1 - Installing the electric panel	14
3.2.2 - Connecting the sweeping air heating device to the panel	15
3.2.3 - Assembly of the fibre optics	15
3.2.4 - Electrical connection	16
4 - FUNCTIONALITIES OF THE ZFDM-4 DUST MONOTOR.....	18
5 – INTERACTIVE MENUS.....	19
5.1 - Information Menu	20
5.2 - Measure / Alarm blockage menu	21
5.3 - Calibration Menu	21
5.3.1 - Pre-Calibration (Commissioning)	22
5.3.2 - Calibration	22
5.3.3 - Checking (Verification of drift)	22
5.3.4 - Record when measuring weight	23
5.3.5 - Weight Measurement Correction	23
5.4 - Configuration Menu	24
5.5 - Others Settings Menu	25
5.5.1 – Adjustment of fibre optic fouling	25
5.5.2 – Adjustment of 4-20mA outputs	27
5.5.3 – Adjustment of the serial connection	28
5.5.4 – Bargraph setting	28
5.5.5 – Averaging measurements	29
5.5.6 – Measurement offset	29
5.5.7 – Sensor alarm adjustments	30
5.5.8 – Threshold hysteresis	31
5.5.9 – Adjusting the time and date	31
5.5.10 – Language display	31
5.5.11 – Other adjustments (Reserved for Fuji Electric)	31
6 – COMMISSIONING.....	32
6.1 – First commissioning.....	32
6.2 – First Setting	32

7 – CALIBRATION EXAMPLE	32
8 – MAINTENANCE	33
8.1 – <i>Cleaning the fibre optic tips on the sensor side</i>	33
8.2 – <i>Cleaning the sensor unit</i>	33
8.3 – <i>Drift monitoring</i>	33
9 – SPARE PARTS	34
10 – ANNEXES	35
10.1 – <i>Position of the switches and terminals on the main board</i>	35
10.2 – <i>Calibration control unit</i>	36
10.3 – <i>230V~/ 115V~SWITCH</i>	37
10.4 – <i>Using the output relays</i>	37
10.4.1 – <i>Contact characteristics</i>	37
10.4.2 – <i>Relay 1 to 4</i>	37
10.5 – <i>Problems / Solutions</i>	38
10.5.1 – <i>Display of the control fault of the light emitted</i>	38
10.5.2 – <i>Display of the fault 'Thermocouple fault'</i>	38
10.5.3 – <i>Display of a fault 'Tp Sensor low'</i>	39
10.5.4 – <i>Display of a sweeping air fault</i>	39
10.5.5 – <i>Display of an acquisition monitoring fault</i>	39
10.5.6 – <i>Display of the fault '420mA Line Fault'</i>	39
10.5.7 – <i>Display of the fault 'Value Locked'</i>	40
10.6 – <i>Measurement offset</i>	40
11 – "High Temperatures" option	41
<i>Assembly / Connections:</i>	41
<i>Settings:</i>	42

PRECAUTIONS FOR ASSEMBLY AND OPERATION

Installation :

The sensor :

- The sensor mounting flange must be welded directly to the flue duct without any intermediate piece, to prevent stray reflections.
- For flue duct diameters of less than 1 meter, it is imperative that the flange be mounted such that the long side of the sensor is parallel to the direction of the flue gas flow.
- The mounting flange of the sensor must be mounted such that the sensor is flush with the inner wall of the flue duct.
- Comply with the radius of curvature of the fibre optics (10cm minimum)
- Do not exceed the maximum fibre optic temperature on the sensor side (350°C with sweeping air as per recommendations). The sweeping air must be dry and oil free.
- As soon as the sensor is fixed to the flue gas duct, the sweeping air and the heating resistor must be in operation at all times to avoid condensation which would result in dirty deposits which could clog the fibre optics.

The electric panel :

- Keep the cabinet electronic away from any sources of heat and vibration, whilst ensuring that the fibre optics are not too tight.
- Pay attention to the signal & supply cable routing in order to keep them away from any power cables.
- The power supply of the panel must be made in TN-S (equal-potentiality of Neutral and Earth)

Before energising :

- Make sure that the mains voltage corresponds to the voltage chosen on the S2 switch (upper left of the main printed circuit board)
- Do not activate the voltage selector switch S2 when the unit is energised.
- Make sure that the wiring is correct and that all the terminal screws are tightened.

NOTE: A correct positioning of the fibre optics in their housings on the sensor and panel side is indispensable in order to avoid any loss of sensitivity of the unit, and to ensure its optimum operation. Any change in positioning of the fibers in their fitting requires an operation to "Commissioning" (see §6.1 page 32), recalibration (§5.3.2 page 22) and zero adjustment fouling (§5.5.1.2 page 26).

1 - PRESENTATION

The FUJI ZFDM-4 is in conformity with AFNOR NF X 43-302.

Its operating principle was qualified for use in controlled installations under N° 78 01, approved for thermal power stations greater than 9300 kilowatts (8000 th/h) under N° 78.1.01.923.1.0 by decision of the DEPARTMENT OF MEASURING INSTRUMENTS on 25/09/1978.

The use of modern electronics combined with a microprocessor and a graphics display makes it easy to use and with increased parameters.

The use of a high-power LED-based light source with dual channel analogue acquisition and monitoring for fibre optic fouling gives both improved quality measurements and processing.

1.1 - General Technical Specifications

Power supply	: 230V~ / 115V~ (+10/-15%) 50Hz/60Hz
Consumption	: 50VA on average. (550VA with heater)
Housing operating T°	: -20°C to +50°C.
Measuring range	: 0 to 1000 mg
Display resolution	: 0.1 mg (for a scale less than or equal to 100mg)
Analogue output signal	: 3 x 4-20 mA outputs (750Ω maximum load)
Printer output/Calculator	: RS 232 / RS485
Fibre optics	: Tip and duct in SS. Length 1,20m and 2,20m as standard Radius of curvature 10cm minimum
Housing	: Sealed to IP 55
Dimension	: 300 x 400 x 200
Weight	: 10 kg

To avoid any damage during transportation, the FUJI ZFDM-4 is delivered in four parts :



- The electric panel
- A fibre optic transmitter
- A fibre optic receiver
- The sensor with its support

1.2 - Description of the electronic circuits

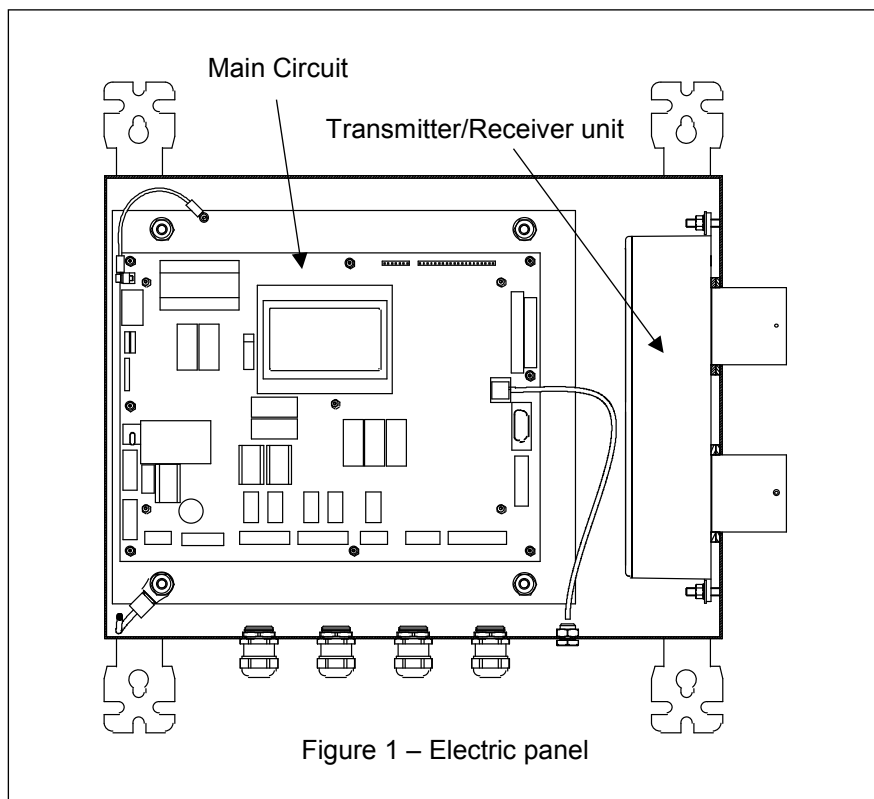

Figure 1 – Electric panel

The Fuji ZFDM-4 electronics comprises 2 circuits :

- The main circuit in which are combined the logic slaving functions and power supply.
- The Transmitter/Receiver unit

1.2.1 - Main Circuit

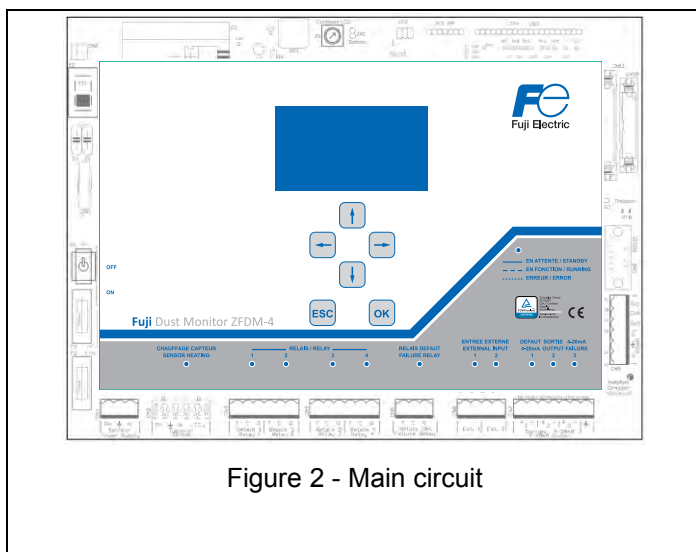

Figure 2 - Main circuit

All the ZFDM-4 functions depend on this circuit, which is equipped with a microprocessor which manages the measurement's acquisition & processing, including the man-machine interface using an LCD display with a 6 button keypad. The microprocessor carries out various functions:

- Managing the light emitted
- Processing of the measurements
- Display
- Managing the 4-20mA outputs
- Controlling the sensor temperature,
- Managing of alarms and faults,

The main circuit comprises the electrical supply circuit which supplies the various voltages necessary for operating the electronics.

Detail of the front face of the main board:

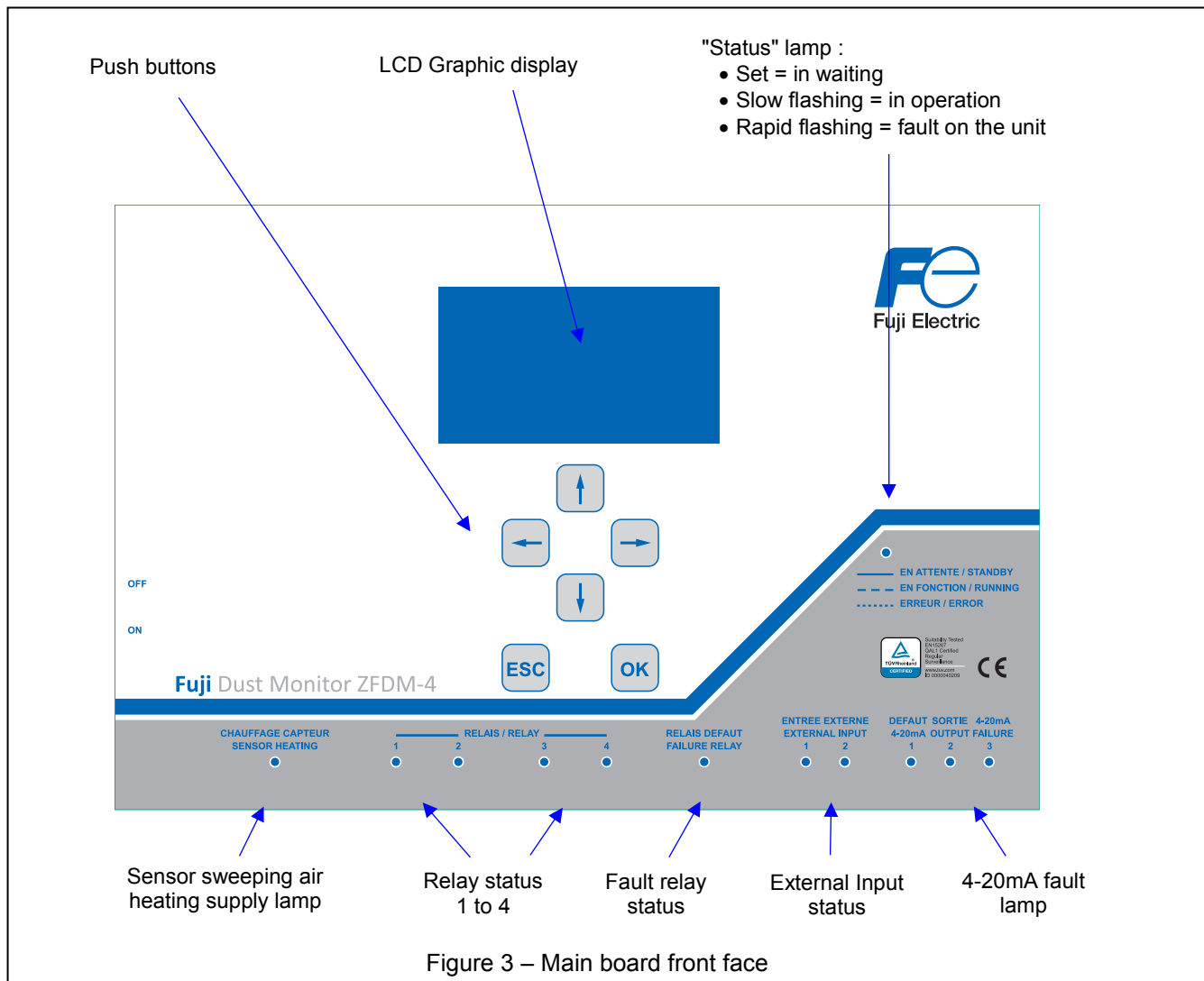

1.2.2 - Transmitter/Receiver unit

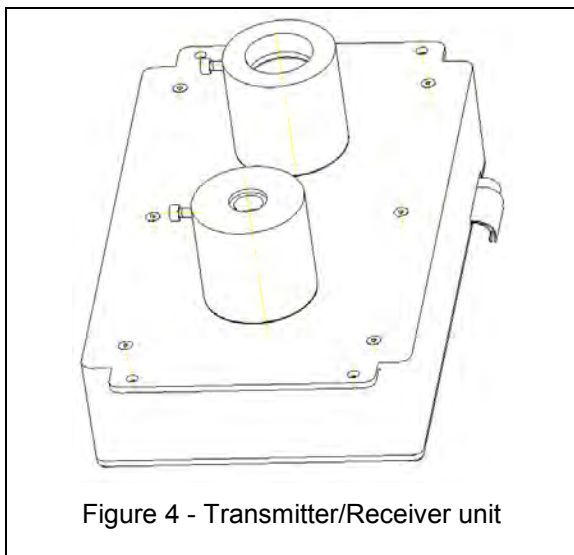

It comes in the form of an aluminium housing.

The transmitter fibre optic and the receiving fibre optic are fitted on top in order to connect the sensor to the panel.

The transmitter / receiver unit is connected to the main board (CN10 and CN11 connectors) by two ribbon cables.

2 – OPERATING PRINCIPLES FOR THE FUJI ZFDM-4

In order to properly install and configure the ZFDM-4 dust monitor, it is necessary to take into account some operating principles it uses.

2.1- Measuring principle

A light ray is sent into either a flue gas duct or a space to be measured, the light is then reflected in various directions by the airborne particles. The intensity of the reflected light which is at an angle α compared to the emitted light, depends on the angle, shape, colour and size of the particles. For a given type of dust, the luminous flux is proportional to the amount of dust.

Operation :

The electronics can be broken down into :

- a light generator, controlled and modulated to 1000 Hz
- a receiver for filtered light, synchronised to 1000 Hz (in order to only take into account the light sent by the unit).
- an analogue/digital processing unit, for analysis and display of the dust rate.

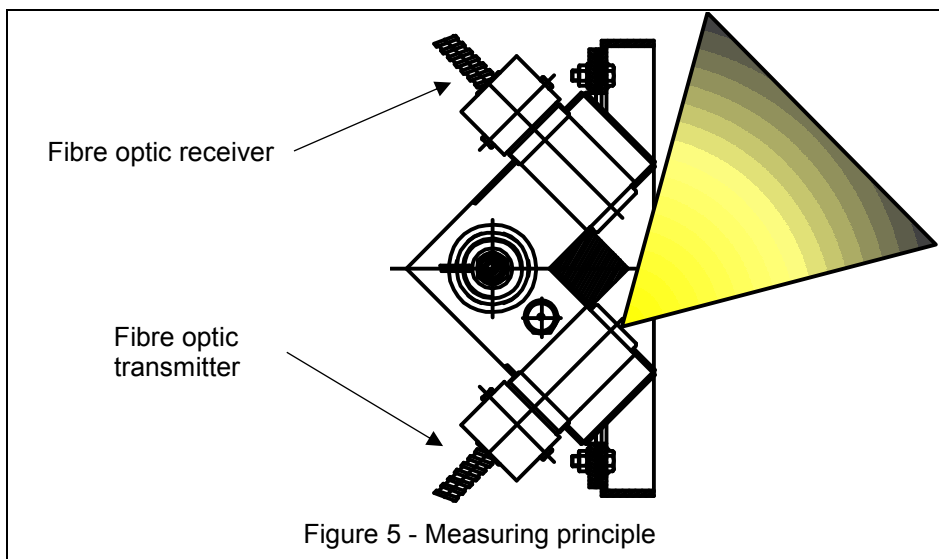

In order to keep the dust monitor away from the vibration and heat of the flue duct, two fibre optic cables handle the connection between the sensor and the processing electronics.

The fibre optic cables are positioned at 90° to each other. A sweeping air system ensures that the fibre optic tips are kept clean.

2.2 - Calibration principle

In order to properly calibrate the ZFDM-4, one must first understand the principle and calibration of dust measuring devices which use an optical process:

The principle of dust measurement by reflection is to quantify the light reflected by the particles.

We have seen that the quantity of light reflected depends on :

- the quantity of light transmitted.
- the angle formed between the light transmitter and receiver.
- the grain size and colour of the particles in suspension.

With the amount of light emitted being controlled by the electronics, and the angle between the light transmitter and receiver being constant, we see that for a given type of dust, the amount of light received is proportional to the amount of dust which is airborne.

Since each installation discharges a different type of dust, it is impossible to calibrate the unit in the workshop.

As with any dust measurement instrument using an optical principle, it is mandatory that a weight measurement be carried out for calibration purposes.

A weight measurement consists in passing the gas to be monitored through a filter for a defined time and according to specific conditions in order to collect the dust present, then to calculate the amount of dust according to the weight of the filter before and after sampling.

It is necessary throughout the weight measurement period, to record the values measured by the ZFDM-4, this so as to deduce an average measure to be used as a basis for the correction to be made, further to the results of the weight measurement.

Nota : A menu allows you to save, for a programmable period of 10 to 480 minutes, the values measured by the Fuji ZFDM-4, this so as to deduce an average measure and recover it for the correction due to the weight measurement. Refer to section 5.3.4 on page 24.

The overall operation of the FUJI ZFDM-4 calibration therefore consists in:

- pre-calibrating the device to display a consistent dust measure (estimated average level)
- a weight measurement
- measurement correction based on the weighing result.

Calibration operations are then as follows:

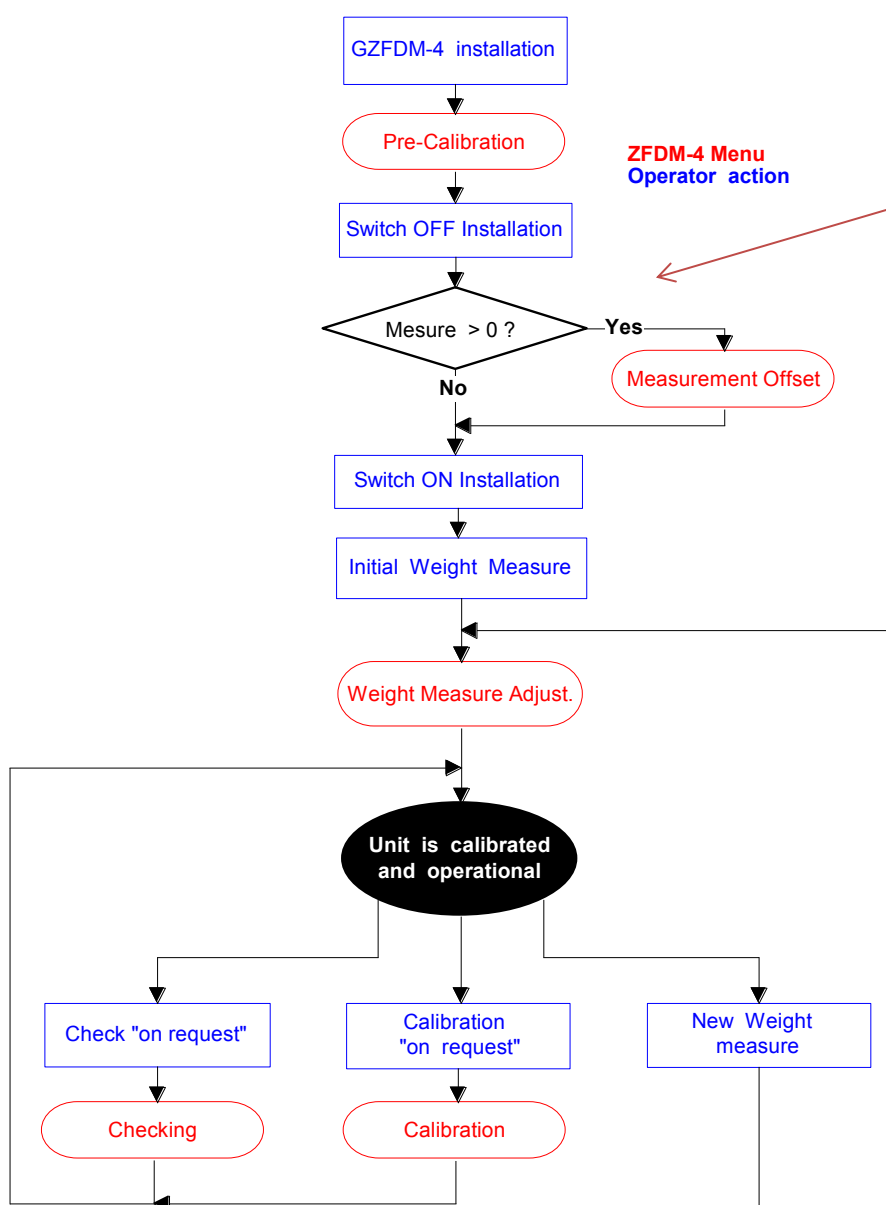

In situations of difficult measure (small diameter flue, flue lining reflective or light, etc ...), it may be a reflection of stray light induces an offset of measurement (measuring different from 0 without dust). In this case, an adjustment of the offset should be made to cancel the disturbance using the submenu "Others Settings" - "Measurement Offset".

The operation consists in:

- Pre-calibrate the unit (as shown on page 22, section 5.3.1) when the system is operating, in order to display the current value of dust rejected and thus define the reference value for the control block calibration

- Then installation stopped, cancel any offset displayed (see paragraph 5.5.6, page 29)

- Finally, restart the installation and adjust the correction coefficient of offset (section 5.5.6, page 29) to display the correct value of dust rejected.

2.3 - Principle of monitoring fouling

Despite the presence of sweeping air to the sensor that will protect the fibre optics from both flue gas heat and dirt deposits, there still remains a long term risk of contamination.

To assess this contamination and as a consequence correct the dust measure or opacity, the light emitting fibre optic comprises a return channel for measuring the light reflection emitted from any dirt which might be on its surface, using a glass rod located at the tip.

When the fibre optic is clean, there is some reflection due to the glass.

When impurities stick to the glass at the tip, the reflection varies according to the colour and quantity of dust.

Monitoring fouling then consists in correcting the dust measurement of the receiving fibre optic according to the evolution of the reflected light in the clogged return channel of the fibre optic transmitter.

On the other hand, the on-screen display and 4-20mA output allows the evolution of this fouling over time to be known, enabling to predict or trigger human intervention for cleaning of the fibre optics.

In the same way as the ZFDM-4 calibration, the return channel of contamination measure varies with the type of dust present.

To make an effective correction, a learning period is therefore necessary.

To do this, we measure the return channel when the fibre optics are clean, and the device is allowed to "live" until a signal variation of the channel is sufficient to get a high precision of the correction to be made.

At this point, we insert into the calibration control unit, the dirty fibre optics, then the cleaned fibre optics.

The difference between these two measures in the control calibration unit and the signal difference of the return channel will define the correction to be made.

Obviously, all these monitoring and correction operations are automatically carried out by the unit, under the supervision of the operator.

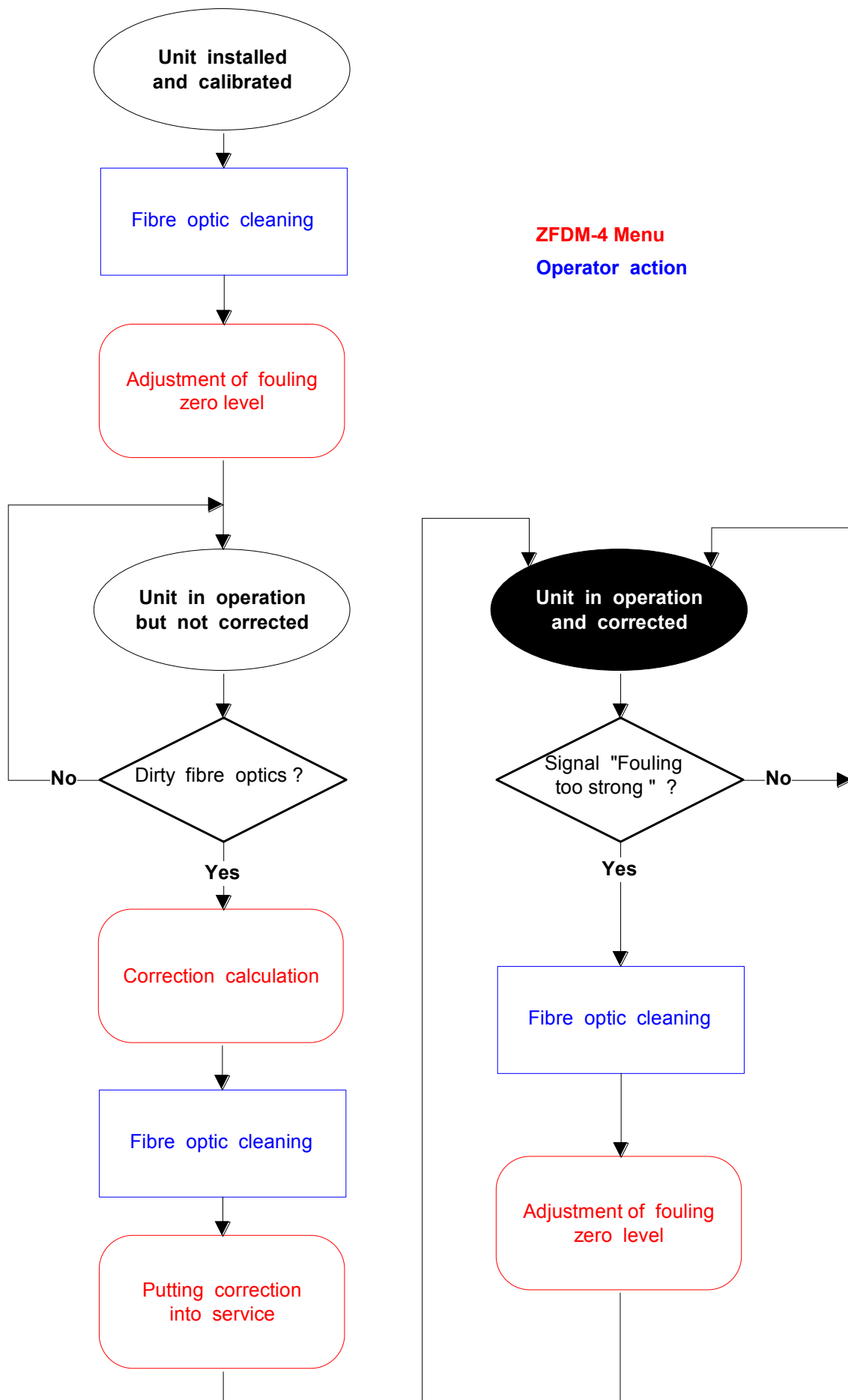

3 - INSTALLATION OF THE ZFDM-4 DUST MONITOR

3.1 - Fitting the sensor in the duct

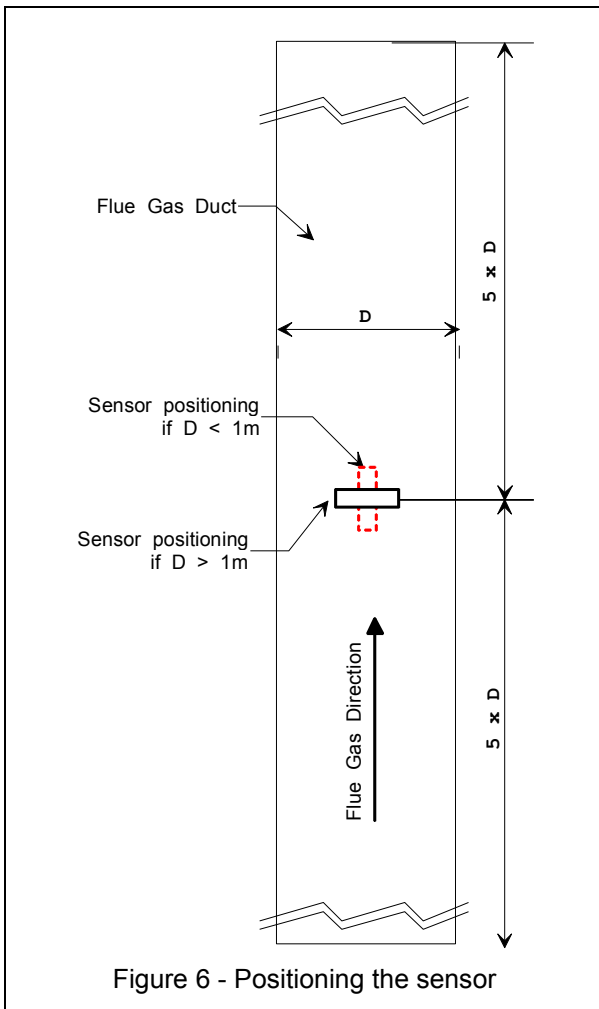

A circular for the management of prevention of pollution in particular requires the following statement:

"The sensor should be installed at a measuring section that meets the conditions of validity as defined in the AFNOR NFX 44-052 standard."

It is recommended:

- to position the sensor so that its long axis is perpendicular to the direction of flow of the flue gas.
- to insulate the sensor giving free passage to the fibre optics

In the case where diameter D of the duct or chimney is less than or equal to 1m, the sensor support should be positioned such that its big axis is parallel to the direction of flow of the flue gas.

So as to not disturb the measure, it is imperative that no element is placed inside the duct at less than 1m from the sensor.

The sensor must be fitted such that it is flush with the inside duct wall.

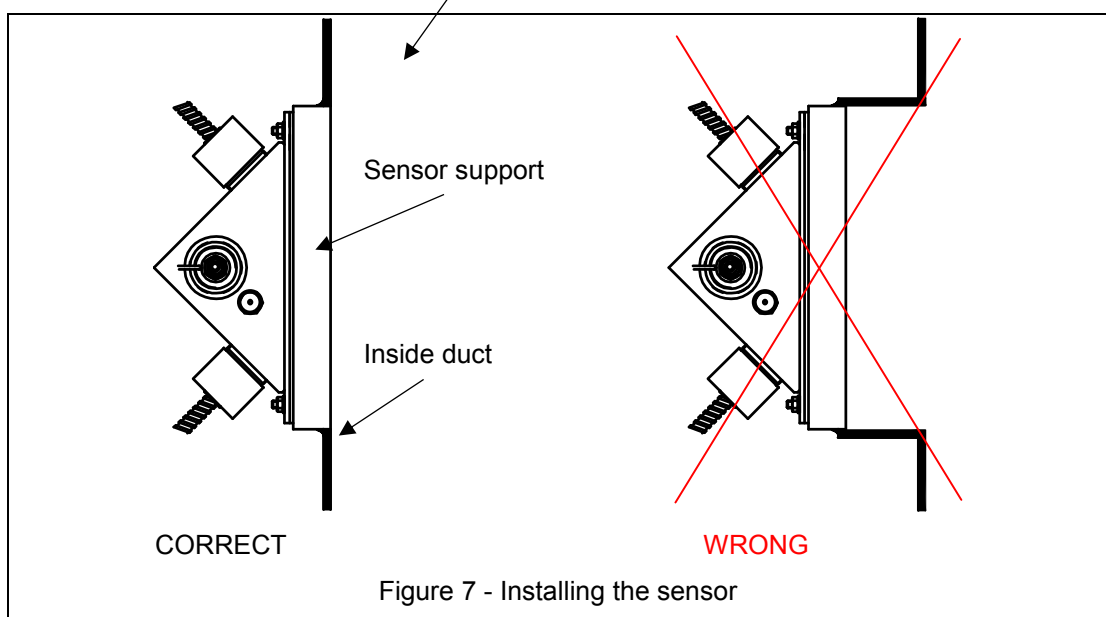

Sensor dimensions with its support :

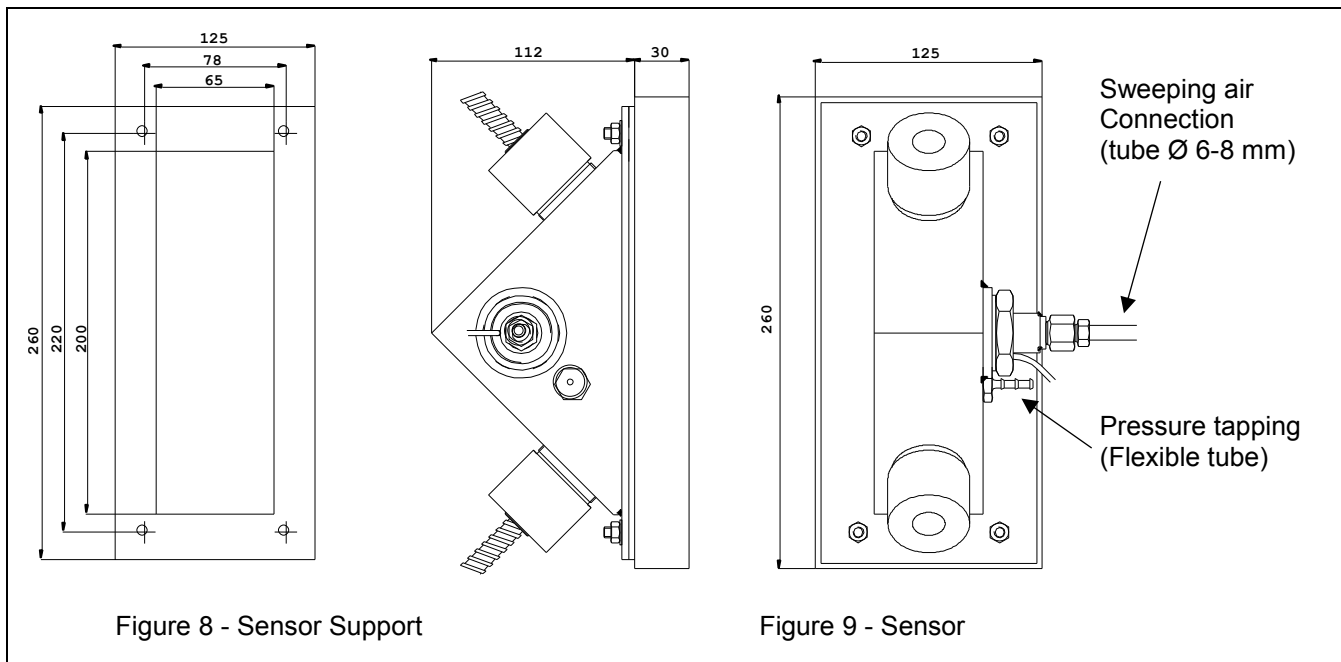

Connecting sweeping air to the sensor

The sweeping air supply will be from a dry air network, clean and oil free. A filter regulator will be used, the displayed pressure will be 400 mbar, the flow rate being about 2 Nm³/h.

The sweeping air must be installed and commissioned before fitting the fibre optics for:

- keeping the sensor clean (dusty flue gas cannot enter the sensor, the sweeping air causes a barrage).
- maintaining a temperature level below 200°C at the fibre optic tips.

An internal pressure tapping point for the sensor is provided and must be connected to the electric panel using the flexible tube provided.

3.2 - Installing the electric panel

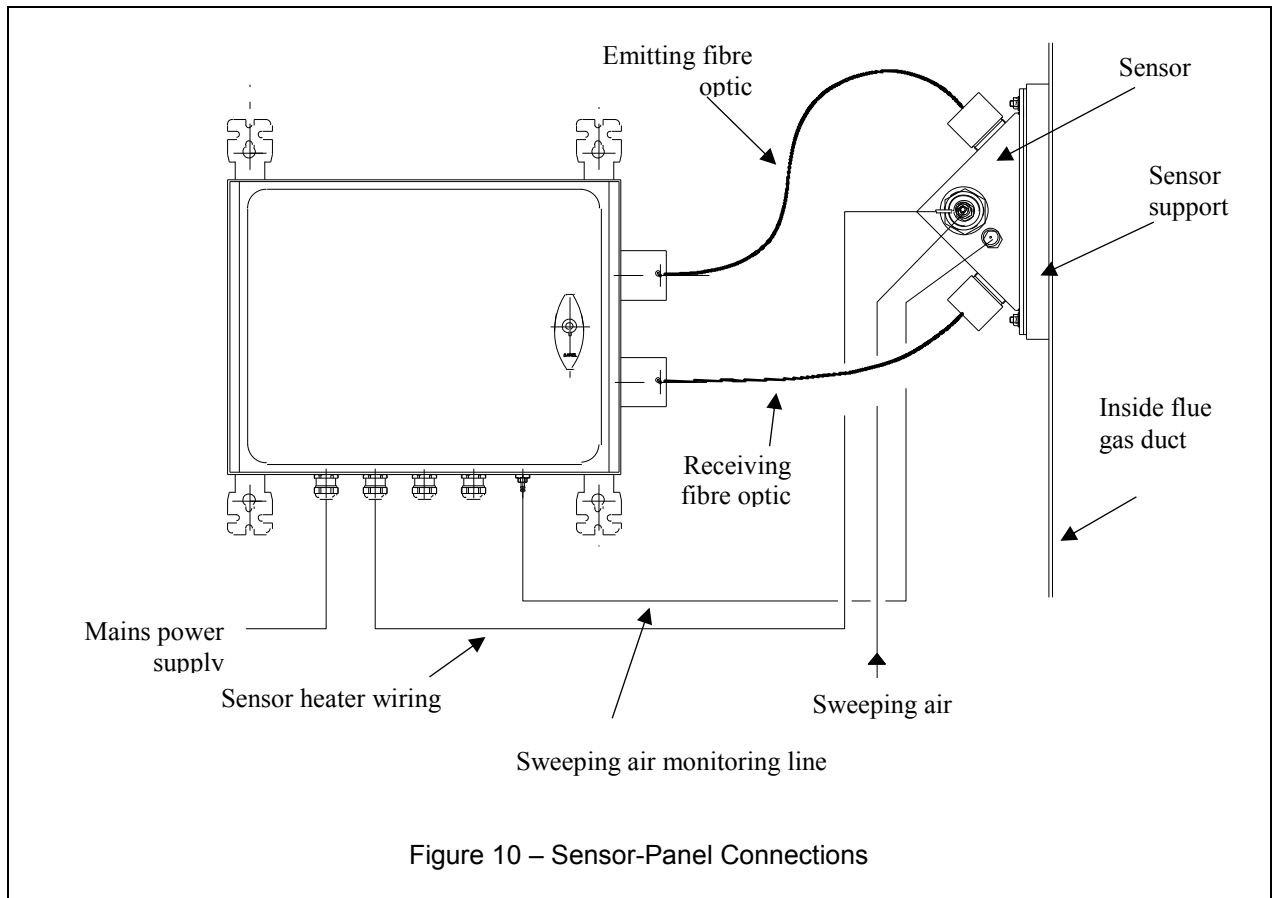

3.2.1 - Installing the electric panel

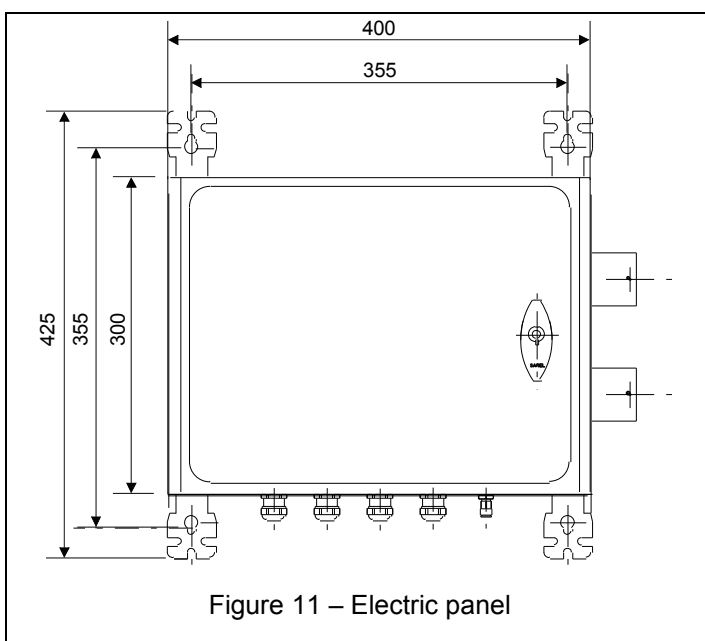

- The panel must be set in a horizontal position, with the cable grommets fitted on the lower part of the panel. Four fixing tabs enable this setting using \varnothing 8 mm bolts.
- The panel must not be subject to any large vibrations and the maximum ambient temperature is 50°C.
- The panel must not be fitted further than 1m from the sensor (or 2m in the case where the fibre optics are 2.2m length), in order that the fibre optics are not too stretched.
- The unit can be installed outdoors.

3.2.2 - Connecting the sweeping air heating device to the panel

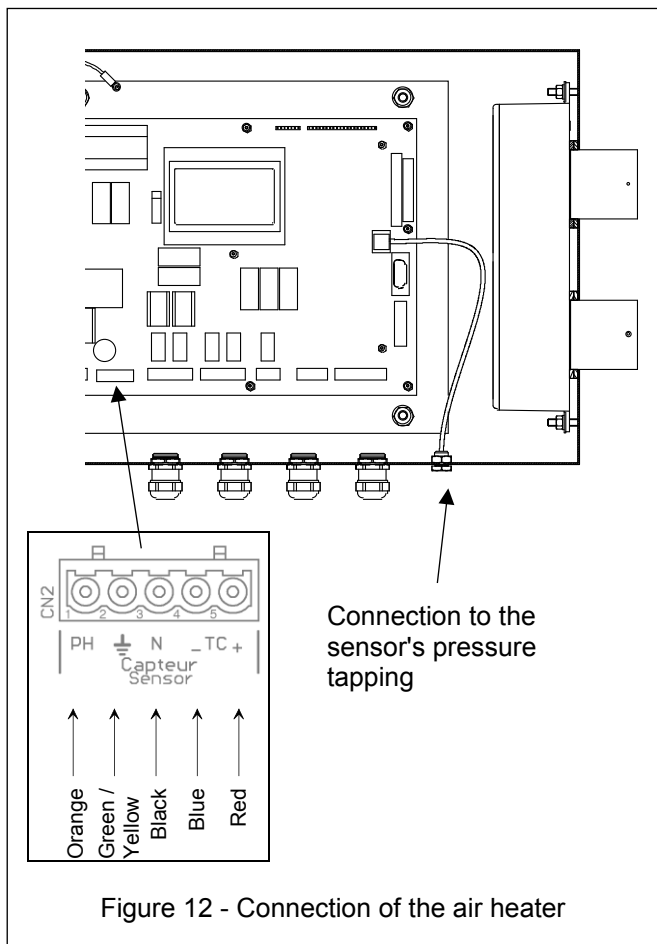

Figure 12 - Connection of the air heater

The air heater consists of a power resistor, supplied with 230V ~ (power 500W), and a temperature sensor (thermocouple type J).

A 4-conductor cable + ground wire is used to connect everything to the electric panel's main board by CN2 (cable length = 5m)

Orange wire and Black wire: 230V ~ (500W)
Red wire and blue wire: thermocouple (+ red - blue)

It is IMPERATIVE to connect the ground wire of the heating resistor to CN2 ground connection.

Connect the sensor's pressure tapping (Figure 9, page 13) to the dedicated connection in the panel (see diagram) using the $\varnothing 6/8$ mm semi-rigid PTFE tube provided.

From the moment the sensor is connected to the flue duct, the sweeping air and the heater resistor must be in operation at all times to avoid condensation which would result in deposits of dirt which could clog the fibre optics.

3.2.3 - Assembly of the fibre optics

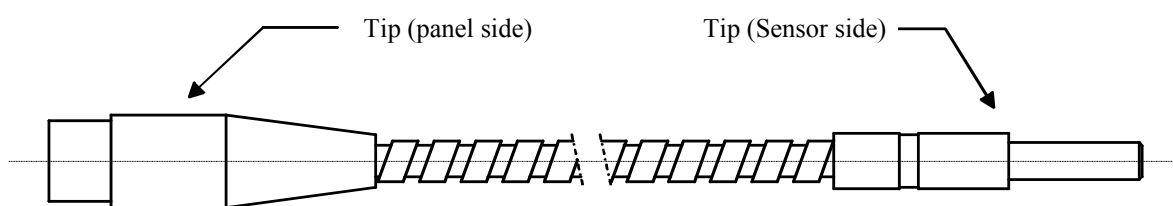

Figure 13 - Fibre optic transmitter

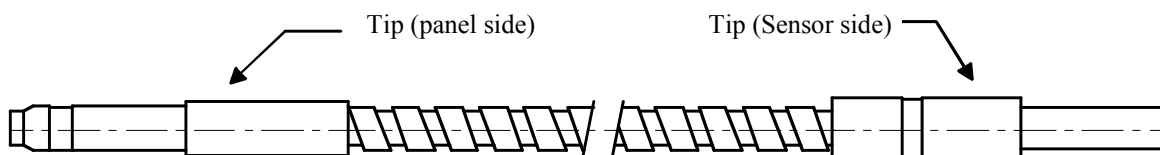

Figure 14 - Fibre optic receiver

In order to not deteriorate the fibre optics, it is imperative to follow these points :

- Radius of curvature minimum 10 cm
- Maximum operating temperature sensor side (with sweeping air) : 350°C
- Maximum fibre optic temperature without sweeping air : 220°C
- Commission the sweeping air as soon as the fibre optics have been put in place, in order to avoid fouling.

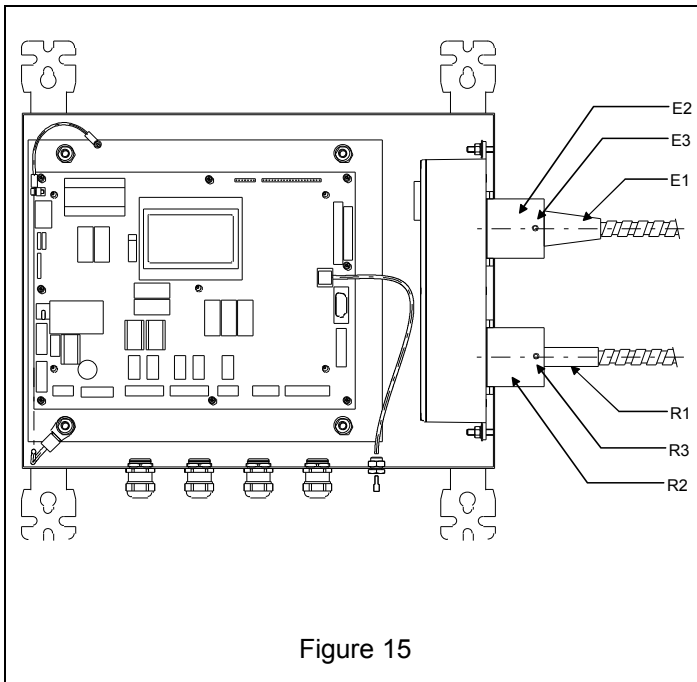

Figure 15

- The fibre optic transmitter E1 is connected to the transmitter/receiver unit E2 in the upper right fitting of the panel.
- Unscrew screw E3 so that it does not hinder the placement of the fibre optic.
- Position the fibre optic in its placement by following the centring spacer, and press it until the stop.
- Block the fibre optic transmitter using the E3 screw.
- The fibre optic receiver R1 is connected to the transmitter/receiver unit R2 in the lower right fitting of the panel.
- Unscrew screw R3 so that it does not hinder the placement of the fibre optic.
- Position the fibre optic in its placement by following the centring spacer, and press it until the stop.
- Block the fibre optic transmitter using the R3 screw.

Place the fibre optics in their placements in the sensor until the stop (see figure 8, page 13); their fixing is ensured by the light blocking of the V tagged screws.

NOTE: A correct positioning of the fibre optics in their housings on the sensor and panel side is indispensable in order to avoid any loss of sensitivity of the unit, and to ensure its optimum operation. Any change in positioning of the fibers in their fitting requires an operation to "Commissioning" (see §6.1 page 32), recalibration (§5.3.2 page 22) and zero adjustment fouling (§5.5.1.2 page 26).

3.2.4 - Electrical connection

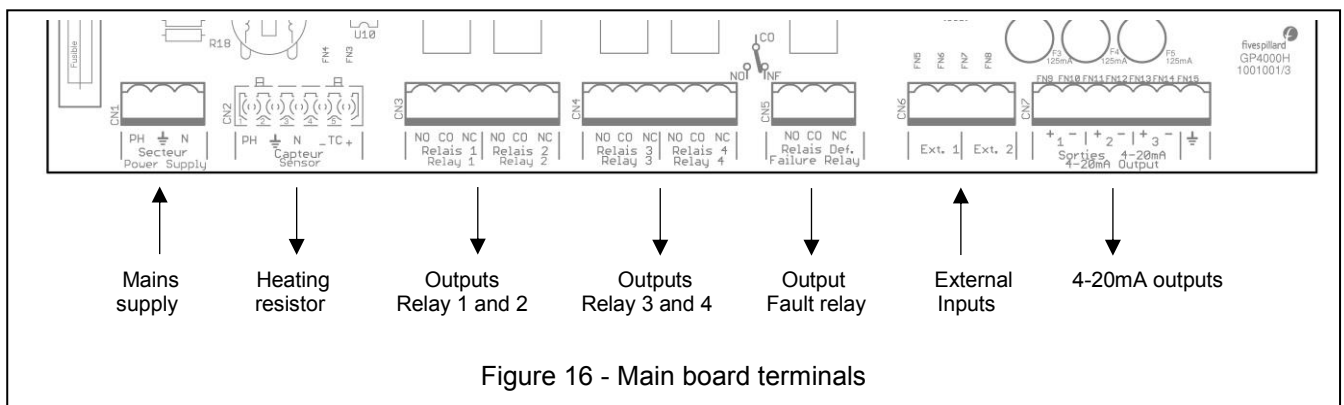

Figure 16 - Main board terminals

- CN1 : Mains supply 230V~/115V~
- CN2 : Sensor heating supply
- CN3 : Relay 1 and 2 outputs (1 SPDT contact)
- CN4 : Relay 3 and 4 outputs (1 SPDT contact)
- CN5 : Relay fault output (1 SPDT contact)
- CN6 : External inputs (Not used)
- CN7 : 4-20mA outputs (3 isolated outputs)

SPDT contact : CO = Common, NO = Normally Open, NC = Normally Closed

CN1 : Mains supply :

Connect the phase (terminal PH), neutral (N terminal) and Earth (earth symbol) to the connector CN1. Power can be 230V~ or 115V ~ (+10% / - 15%), 50 or 60Hz, the consumption of the unit alone is 50VA, to which must be added 500VA if the sweeping air heater is used. Protect the power supply by a suitable circuit breaker, used on an appropriate section of cable.

CN2 : Sweeping air heater supply :

In the case where the sweeping air heater is used, connect it to CN2 following the instructions in paragraph 2.2.2. The connection must be carried out with the power-off, and the mains supply isolated.

CN3 : Output relays 1 and 2 - CN4 : Output relays 3 and 4 :

Connect the relay outputs 1 and 2 in CN3, and relay outputs 3 and 4 in CN4. Each relay has a SPDT contact, the breaking capacity is 1A / 125V / 60W. When the relay is at "Rest" position (relay not energized), the "Common" terminal marked 'CO' and the "Normally Closed" terminal marked 'NC' have continuity. The corresponding indicator lamp is not lit on the front. When the relay is set to "Work" (relay energized), the "Common" terminal marked 'CO' and the "Normally Open" terminal marked 'NO' have continuity. The corresponding signal lamp is lit on the front.

CN5 : Relay fault output :

Connect the relay fault output in CN5. This relay has a SPDT contact, the breaking capacity is 1A / 125V / 60W. The relay is supplied failsafe (positive safety). In the event of a fault (or power failure), the contact is between the terminal "Common" marked 'CO' and the terminal "Work" identified 'Normally Open (NO)'. The corresponding signal lamp is lit on the front (if the device is powered). If there is no fault, the contact is between the terminal "Common" marked 'CO' and the terminal "Normally Closed" marked 'NC'. The corresponding indicator lamp is off on the front.

CN6 : External inputs :

2 inputs "Dry contacts" can be connected here. (Future functionalities).
DO NOT CONNECT POWER SUPPLY SOURCES.

CN7 : 4-20mA Output:

Connect the 4-20mA current outputs in CN7. These outputs are active and should be connected only to passive inputs. The load should not exceed 750Ω for each output. Comply with the Polarity.

If a current output is configured in the device and no device is connected to it (or the fuse of this output is faulty), the corresponding signal lamp lights-up on the front.

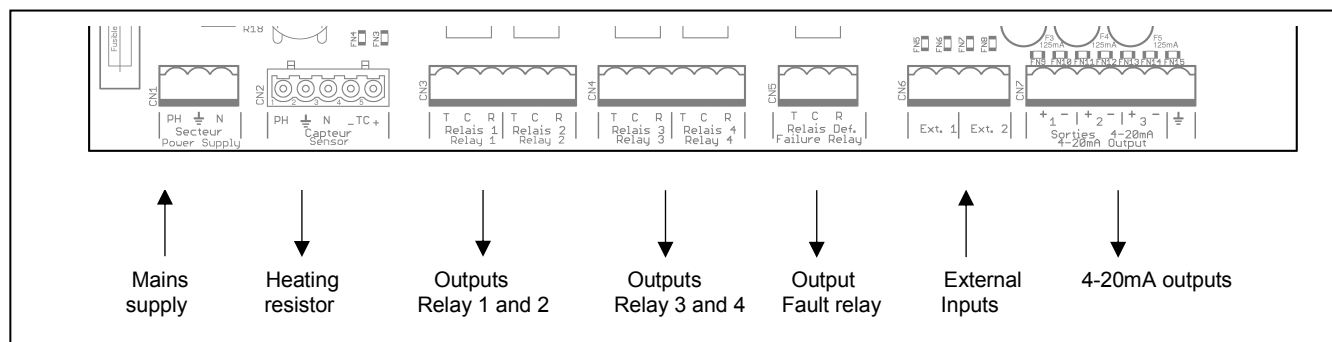

CN8 – CN9 : Liaison série RS232 ou RS485:

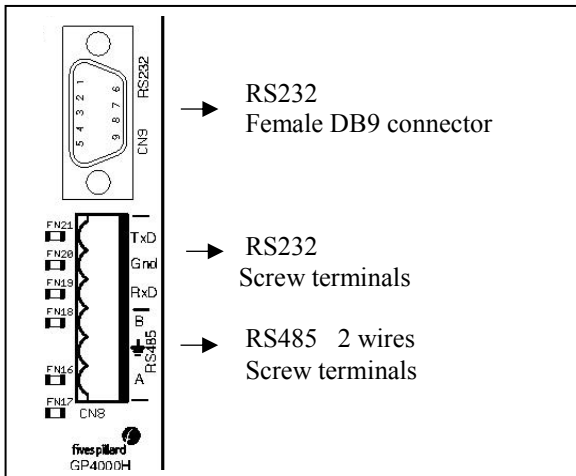

A serial link is available according to standard RS232 and RS485 standard (2 wires).

- Connect to CN9 if you wish to use a connection with a DB9 RS232
- Connect to CN8 if you want to use RS232 or RS485 output with screw terminals.

You can use either the RS232 connection or RS485 by connecting the corresponding outputs, but it is not possible to use two connections at the same time.

Refer to section 5.5.3 (page 28) to configure the serial port.

4 - FUNCTIONALITIES OF THE FUJI ZFDM-4 DUST MONITOR

- **Display**
 - 2 measuring scales separately adjustable from 10 to 1000mg, with automatic transfer from one to the other .
 - Display resolution : 0.1 mg (for a scale <=100mg), 1 mg otherwise.
 - Adjustable damping from 1 to 120 s
- **Monitoring of fouling**
 - Monitoring and correction of fouling after a learning period
 - Pre-fouling alarm with adjustable maximum
- **Output current**
 - Three 4-20mA output currents separated and electrically isolated.
 - Each output can be configured for one of the two scales for the clogging condition of the unit
 - Monitoring of the status of the 4-20mA outputs and possible generation of an alarm.
- **Thresholds**
 - Four definable thresholds on both scales
 - Each threshold can be defined independently as high or low threshold.
 - Each threshold can control a relay.
- **Faults**
 - Monitoring and managing of sensor faults.
 - Sensor faults : low temperature, thermocouple fault, sweeping air pressure fault
 - General faults : luminous flux emission control fault, measuring chain fault
- **Time and date**
 - Time-dating of appearance and disappearance of faults / alarms
- **Various**
 - Clear Display on a graphic LCD
 - 6 Push-buttons for navigating menus (Next / Previous +/- OK / Cancel)
 - Serial connection RS232/RS485 (1200 to 38400 Bds, 8 bits, no parity, 1 stop bit)
 - 4 configurable relays, 1 General fault relay
 - Choice of display in French or English
 - Daily monitoring of two measuring chains (low range and high range)
 - Graphic display of the evolution of the adjustable measure from 2 minutes to 24 hours

5 – INTERACTIVE MENUS

The tree diagram of the various menus is as follows :

GENERAL MENU

—	INFORMATION MENU	
—	MEASURE / ALARM LOCKING MENU	
—	CALIBRATION MENU	
	Pre-calibration (1 st Start-up)	
	Calibration	
	Checking (verification of drift)	
	Weight Measure Record	
	Weight measurement Correction (after monitoring by weight)	
—	CONFIGURATION MENU	
	Unit	(None / mg/m ³ / mg/Nm ³ / %)
	Low scale	(Adjustable scale from 10 to "High scale")
	High scale	(Adjustable scale from "Low scale" to 1000)
	Sensor type	(Cold/ TC / PSL / TC + PSL / - TC - PSL)
	Threshold 1 value	(0 to High scale)
	Threshold 1 type	(Not used/ Low Threshold / High Threshold)
	Threshold 2 value	(0 to Measuring scale)
	Threshold 2 type	(Not used/ Low Threshold / High Threshold)
	Threshold 3 value	(0 to High scale)
	Threshold 3 type	(Not used/ Low Threshold / High Threshold)
	Threshold 4 value	(0 to Measuring scale)
	Threshold 4 type	(Not used/ Low Threshold / High Threshold)
	Relay 1 output	(Threshold1/Threshold2/Threshold3/Threshold4/ Fouling)
	Relay 2 output	(Threshold1/Threshold2/Threshold3/Threshold4/ Fouling)
	Relay 3 output	(Threshold1/Threshold2/Threshold3/Threshold4/ Fouling)
	Relay 4 output	(Threshold1/Threshold2/Threshold3/Threshold4/ Fouling)
—	OTHERS SETTINGS MENU	
	Setting fouling	
	4-20mA setting	
	RS232/RS485 setting	
	Bargraph Configuration	(Scale 1 or 2 / Period from 2min to 24h)
	Average of measures	(from 1 to 120s)
	Measurement offset	
	Adjustment of alarms of heated sensor	
	Threshold Hysteresis	
	Time/Date adjustment	
	Display language adjustment	
	Reserved for Fuji Electric	

The man-machine interface is by use of a LCD display with a 6 button keypad to navigate in the menus and enter the values.

In normal operation, the display indicated the current measure, its evolution in the form of a graph.

In the case where one or several alarms or faults are present, the line 'Current date and time' is alternated with the display of the fault.

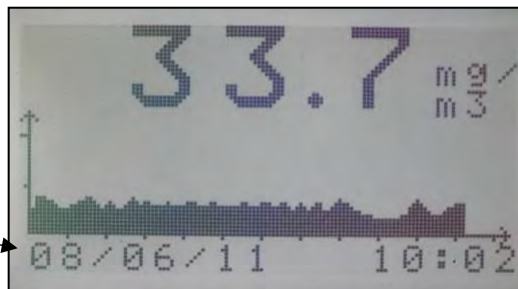

To enter into the various menus, press a button.

The general menu is displayed :

Scroll the menus by pressing \uparrow or \downarrow and confirm with **OK**, or press **ESC** to return to normal display.

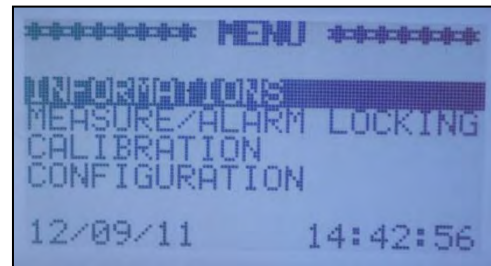

Pressing **OK** validates the chosen menu, pressing **ESC** cancels the operation and returns to normal display.

5.1 - Information Menu

The information menu allows to display by successive screen pages :

- The information concerning the sweeping air heater of the sensor
 - Current temperature, Control range, Measure pressure
- The configuration of the measure
 - Low scale, high scale, units, damping, calibration control unit value
- The setting of thresholds
 - Value and type of threshold
- Use of relays
 - Relay allocation
- Control of the light ⁽¹⁾
 - Current value of the LED, setpoint value...
- electronic synchronisation data ⁽¹⁾
- The measuring amplifier gain data ⁽¹⁾
- Setting of the 4-20mA N° 1 output
 - Use, monitoring, adjustment, current value
- Setting of the 4-20mA N° 2 output
 - Use, monitoring, adjustment, current value
- Setting of the 4-20mA N° 3 output
 - Use, monitoring, adjustment, current value
- Fouling
- Operation
- Memorised alarms
- Program version

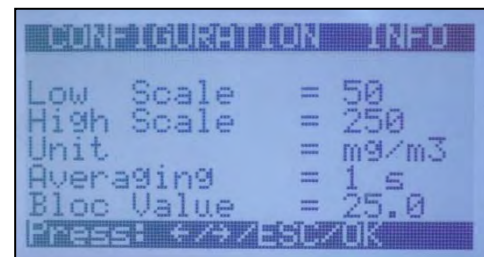

From the general menu, choose the menu "INFORMATION", pressing \uparrow and \downarrow and confirm with **OK**.

The information is displayed per page by pressing the buttons \rightarrow and \leftarrow . Press **ESC** to exit.

NB : The page "MEMO FAULT" displays the last alarm which occurred. It is possible to scroll the alarms in memory by pressing \uparrow and \downarrow . To erase the memory, press **OK**.

⁽¹⁾ : this information might be asked of you, if you contact our after-sales service.

5.2 - Measure / Alarm blockage menu

In order to calibrate or change the configuration of the ZFDM-4, or intervene on its sensor, without any measures or false alarms being transmitted to the supervision system, it is possible to freeze the current value or set a desired value.

To do this, select in the sub-menu "MEASURE/ALARM LOCKING" from the general menu, with the buttons \uparrow and \downarrow , and confirm by **OK**.

The possible choices are (scroll by using \rightarrow and \leftarrow) :

- "Normal processing" : de-activates the current blockage
- "Blocked at xx.x mg" : blocks the measure to xx.x (measure in process)
- "Fixed at xx mg" : Force a measure to the value xx, xx variant of 1 to the value of the high scale by steps of 1 mg.

Press **OK** to confirm.

If the choice is "Blocked" or "Fixed", the time of the blocking is then asked for.

- "Until cancellation" : the value is blocked or fixed until the status « Normal processing » is chosen
- "For 30mn", "For 60mn", "For 120mn" : the blockage is done for the time chosen, then the normal processing automatically takes-over .

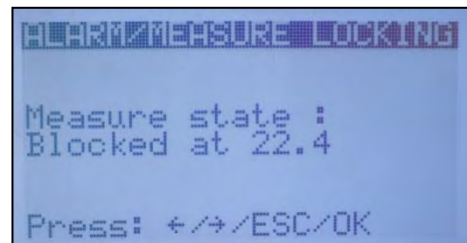
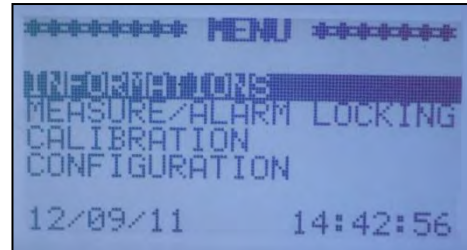

5.3 - Calibration Menu

As specified in paragraph 2.2, FUJI ZFDM-4 calibration operations consist in:

- pre-calibrating the unit in order that it displays a coherent measure according to the dust quantity (average estimated value)
- a weighing measure
- measuring correction according to the result of the weighing

For this, the CALIBRATION menu of the ZFDM-4 has 4 sub-menus :

- **Pre-Calibration**: for the 1st start-up in order to display a coherent value (which is not necessarily "exact").
- **Calibration** : to re-calibrate the unit afterwards
- **Checking**: to check for any eventual drift and to re-calibrate if necessary.
- **Weight Measure record**: to record the values measured by the ZFDM-4 during weight measurements performed simultaneously. An average value is then calculated as the basis for the correction made later by the menu below.
- **Weight Meas. Setting**: to adapt the measure according to the result of the weighing result carried out.

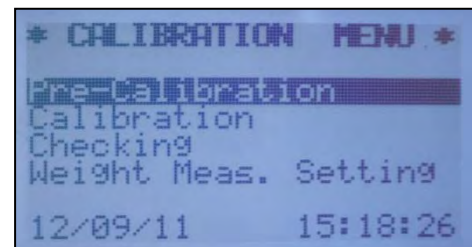

**All operations of pre-calibration, calibration, weight measurements, etc, must be performed on the values in the low scale of the device.
If measurements exceed the low scale, it must be modified to be greater than the displayed measurements.
Otherwise, all the following calibration can not be performed.**

5.3.1 - Pre-Calibration (Commissioning)

This menu enables to carry out a first calibration of the unit in order to have a reference measure of the ZFDM-4 to be able to later adjust it after a weighing measurement.

From the "CALIBRATION" menu, select the sub-menu "Pre-Calibration" using ↑ and ↓ and confirm with **OK**.

The sub-menu "PRE-CALIBRATION" is displayed.

The fibre optics inserted into the sensor in the duct, and installation (flue gas) in operation, display the measure required using → and ← . The measure displayed must correspond to an objective value and be close to reality, without necessarily being precise, since it will be tuned later by comparison with a weight measure.

Using ↑ and ↓, the sensitivity of the unit can be adjusted.

Press **OK** to confirm the displayed measure.

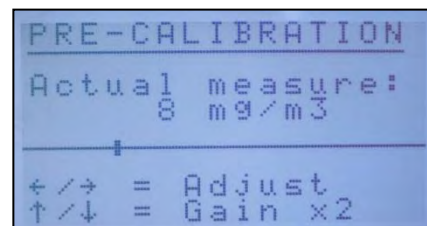

The unit will then attribute a provisional value to the calibration control unit to have a measuring base. For this, you will be asked to insert the calibration unit between the fibre optics and to initiate a calibration. Follow the instructions on the screen.

The unit is then pre-calibrated and will display a base measure which can later be tuned and corrected by a weighing measure.

Before any calibration operation, the ZFDM-4 must be left energised for the previous 24H, door closed, in order to homogenise and stabilise the internal temperature of the electric panel.

5.3.2 - Calibration

This menu allows to re-do a unit calibration.

From the "CALIBRATION" menu, select the sub-menu "CALIBRATION" using ↑ and ↓ then confirm with **OK**.

The value of the calibration control unit is displayed. Press **OK** to confirm or if necessary to modify it using the buttons ↑, ↓, → and ← .

Follow the instructions displayed on the screen.

5.3.3 - Checking (Verification of drift)

This menu enables to verify that the calibration is always correct.

From the "CALIBRATION" menu, select the sub-menu "Checking" using ↑ and ↓ then confirm with **OK**.

Follow the instructions displayed on the screen

The menu then displays the value of the calibration control unit (comparison value) and the values measured on the two measuring scales.

If the difference between the calibration control unit and the measured value is judged to be too great, press **OK** to restart a calibration.

5.3.4 - Record when measuring weight

As seen above, the calibration ZFDM-4 is pre-calibrated at startup so that it displays a measure that can be corrected with a weight measurement.

A weight measurement is to take for some time (several tens or hundreds of minutes) dust to make a measurement, the result will be given several days later.

This result will then be entered into the unit to correct the measured value at that time by the ZFDM-4.

It is therefore necessary to record the measurement of the dust monitor while the weight measurement to calculate the average value and take it as the reference for the correction to be made in relation to the value provided by the gravimetric .

To facilitate obtaining the measured average, it is possible to perform recording of the measurement.

Three records can be stored for later use.

When starting weight measurement, select the submenu "Weight Measure Record" from the menu "CALIBRATION", using \uparrow and \downarrow then confirm with **OK**.

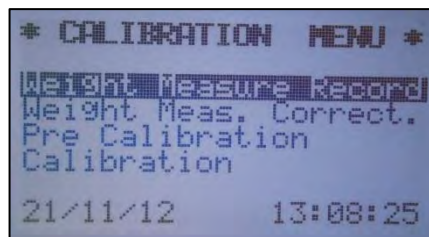

Select the location where the average must be registered with the keys using \uparrow and \downarrow then confirm with **OK**.

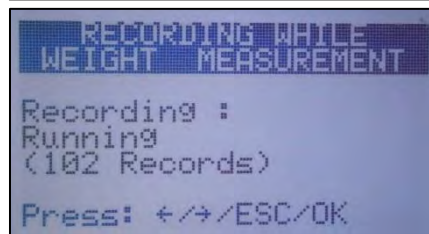

Then select the maximum recording time (from 0:10 to 8:00). And confirm with **OK**.

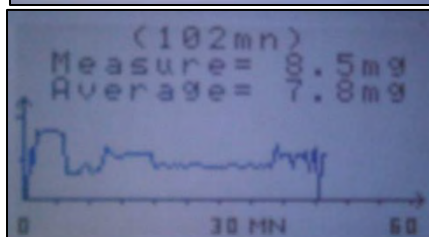

The recording is started, and the LCD displays the current measurement, the average calculated every minute, and the number of minutes recorded.

Recording will stop after the selected time and the average will be calculated and stored for use in the correction weight measurement.

If a recording is in progress and that it is desired to stop it before the scheduled time, select again the menu "Weight Measure Record": After the confirmation of the stop of recording, the current average is calculated and stored.

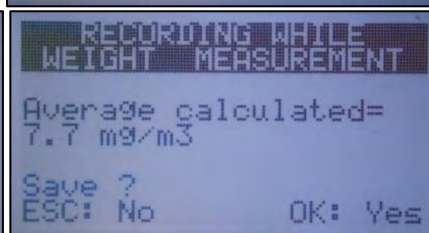
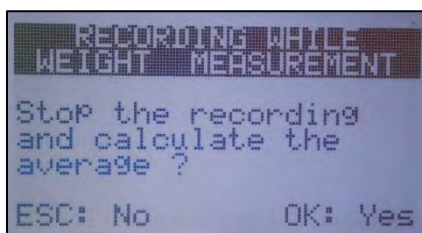

5.3.5 - Weight Measurement Correction

After pre-calibrating the unit, this menu allows to correct the displayed value further to a weighing measure.

During weighing measurement operations, you should note (or record) the average value displayed by the ZFDM-4 in order to enter this value later on the ZFDM-4 with the result of the weighing measure.

From the "CALIBRATION" menu, select the sub-menu "Weight Meas. Correct." using \uparrow and \downarrow and confirm with **OK**.

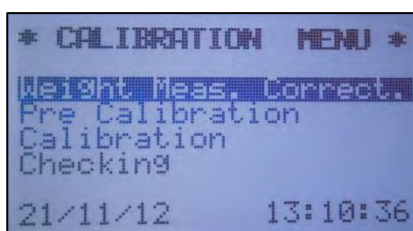

The sub-menu "Weight Measure Correction" displays:

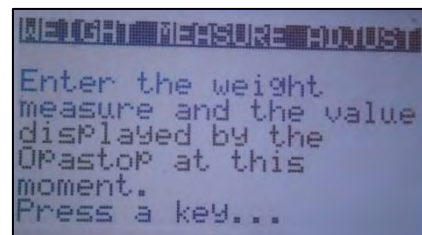

If a recording of measurements was made, a message indicates that an average was calculated and is available for the use of reference measurement. Then press **OK** to use it.

Buttons **↑** and **↓** allow to choose the value to be modified (Result of the weighing measure or measured by the ZFDM-4 during the weighing).

Buttons **→** and **←** allow to increase or decrease the value chosen.

Button, **OK** initiates the operation, whereas **ESC** cancels everything and returns to the previous menu.

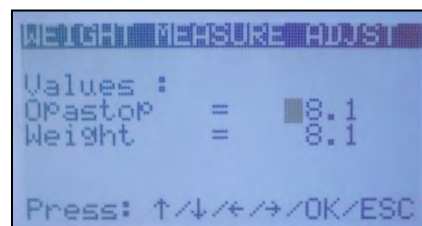

The ZFDM-4 calculates the new value of the calibration control unit and starts a calibration. Follow the instructions on the screen.

The calculated value then becomes the reference value of the calibration control unit for this installation and will serve as a drift monitor and eventually a new calibration.

After this operation, the ZFDM-4 is definitely calibrated.

Note: Keep the unit energised with the door closed for at least 1 hour before doing a calibration

5.4 - Configuration Menu

This menu enables the measuring scales and thresholds of the ZFDM-4 to be configured.

From the main menu, select the sub-menu "CONFIGURATION" using **↑** and **↓** then confirm with **OK**.

The configuration is then displayed.

Choose the element to be modified using the **↑** or **↓** button, and press **→** or **←** to increase or decrease the chosen parameter value.

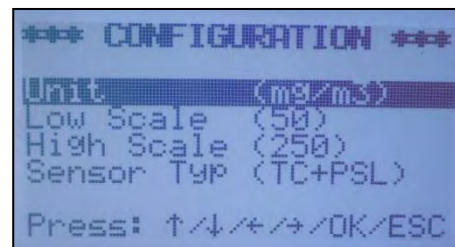

Press **OK** to validate the modified value.

The modifiable elements here are:

- Measuring units
"none" or "mg/m3" or "mg/Nm3" ou "%"
- The calibre of the low scale
from "10" to "1000", without being able to exceed the high scale.
- The calibre of the high scale
from "10" to "1000", without being able to drop below the low scale.
- The type of sensor heating
"Cold" = sensor without heating hair
"TC" = sensor heated and monitored by just a thermocouple
"PSL" = sensor heated and monitored by a pressure measurement
"TC+PSL" = sensor heated and monitored by a thermocouple and a pressure measurement
"-TC-PSL" = sensor heated without any monitoring

- Value and type of 4 thresholds, "Threshold 1" to "Threshold 4"
 - Value of adjustable threshold from "1" to the high scale value
 - Type of threshold
 - "N.U." = Not used,
 - ">" = The threshold is reached if the measured value exceeds the threshold
 - "<" = The threshold is reached if the measured value is below the threshold
- 4 relays attributable to each threshold (Threshold1 to Threshold4) ,or to the fouling threshold defined in paragraph 5.5.1.5 (Fouled) or not used (N.U.)

5.5 - Others Settings Menu

This menu enables the Fuji ZFDM-4 settings:

- Adjustment of fibre optic
- Configuration of the three 4-20mA outputs
- Adjustment of the series connection
- Configuration of the bargraph
- Averaging of measures (Damping)
- Measurement offset
- Adjustment of the air heater monitoring alarms
- Adjustment of the threshold hysteresis value
- Adjustment of the time and date
- Adjustments reserved for Fuji Electric staff.

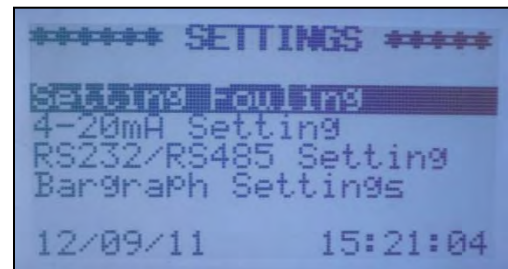

5.5.1 – Adjustment of fibre optic fouling

From the "OTHERS SETTINGS" menu, choose the sub-menu "FOULING SETTING" using the buttons \uparrow or \downarrow and confirm with *OK*.

The sub-menu "FOULING SETTING" will be displayed :

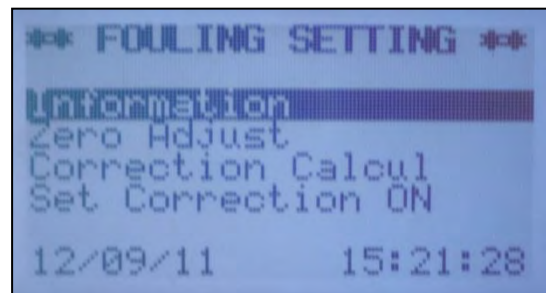

5.5.1.1 – Fouling setting : Information

The option "Information" gives the current status of fouling and the correction given.

- 'Clean Value' is the value of the fouling measuring channel when the fibre optic has been cleaned.
- 'Current Val.' is the current value of the fouling measuring channel 'Foul Rate.' is the current rate of fouling measured.
- 'Correction' is the correction which will be made on the opacity measure totake into account the current fouling of the fibre optic.
- 'In operation' specifies if the operation is carried out or not.

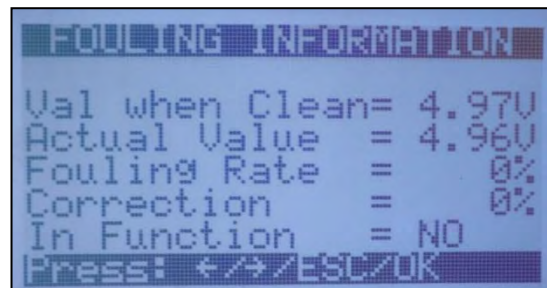

5.5.1.2 – Fouling setting : Zero adjustment

The sub-menu "Zero adjustment" enables to adjust the fouling measuring channel and to memorise the corresponding "zero" value when the fibre optic is clean.

From the menu "FOULING SETTING", choose the sub-menu "ZERO ADJUSTMENT" using the ↑ or ↓ button, and confirm with **OK**.

Follow the indications displayed on the screen :

- A confirmation that the fibre optics are clean is requested
- Then the fibre optics must be placed in the duct sensor
- The system then calibrates the fouling measurement channel.

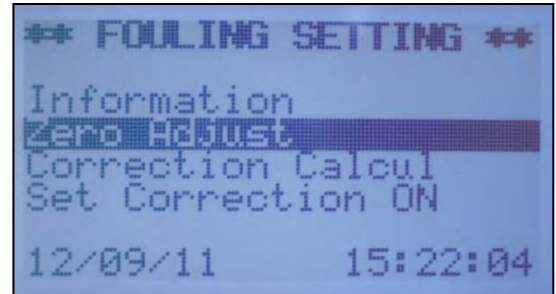

5.5.1.3 – Fouling setting : Calculation of correction

The sub-menu "Correction Calculation" enables to calculate the correction to be made on the opacity measure to limit the eventual effects of fouling on the fibre optics.

To carry out the calculation, it is necessary that the fouling measurement channel gives a minimum fouling rate of 10%, a value of 20% would be preferred.

(Rate available in the Information menu, § 5.5.1.1)

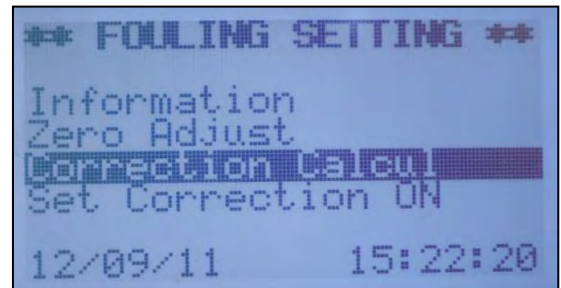

From the menu "FOULING SETTING", choose the sub-menu "CALCULATION CORRECTION" using the buttons ↑ or ↓ and confirm with **OK**.

Follow the indications displayed on the screen:

- Confirmation that the fibre optics are fouled is requested
- The system verifies that the fibre optics are sufficiently clogged
- Then you put the fibre optics in the calibration control unit **without cleaning them**
- Then return the fibre optics to the calibration control unit after cleaning them
- The system then calculates the correction to be made according to the difference in measurement between clean and dirty fibre optics in the calibration control unit, and according to the variation of the measuring channel signal between dirty and clean fibre optics.

5.5.1.4 – Fouling setting: Putting IN /OUT of operation

When a correction calculation to be made according to fouling has been carried out, it is possible to turn the correction on or off.

From the menu "FOULING SETTING", choose the sub-menu "set Correction ON" or "Set Correction OFF" (according to the current calculation status) using ↑ or ↓ and confirm by **OK**.

The option switches alternatively from "Set Correction ON" (when the correction is not applied) to "Set Correction OFF" (when the correction is applied) each time **OK** is pressed.

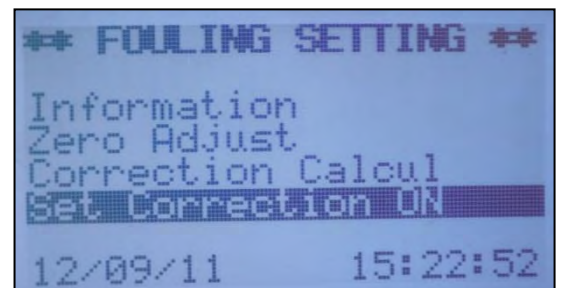

5.5.1.5 – Fouling setting: Threshold limit adjustment

It is possible to define a threshold for the fouling rate which can activate a relay.

This can be useful, for example, generating a signal alerting a significant fouling and requiring an imminent cleaning of the fibre optics.

From the menu "FOULING SETTING", choose the sub-menu "Limit Value Setting" with the buttons ↑ or ↓ and confirm with **OK**.

The screen then displays the fouling threshold value and the relay number which will generate the signal.

Choose the element to be modified using ↑ or ↓, and press the button → or ← to increase or decrease the value of the selected parameter.

Press **OK** to validate the modified value.

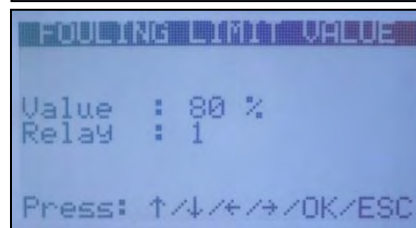
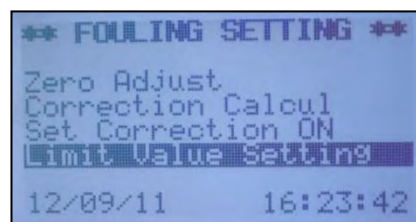

5.5.1.6 – Fouling setting: Alarm threshold adjustment

It is possible to define a threshold for the fouling rate which will activate the fault relay (alarm).

This can be useful for example, to generate a signal alerting of maximum fouling which no longer allows to efficiently compensate for the measured fouling.

From the menu "FOULING SETTING", choose the sub-menu "Fault Value Setting" using the buttons ↑ or ↓ and confirm with **OK**.

The screen displays the alarm threshold value.

Press → or ← to increase or decrease the value, **OK** to validate the modified value.

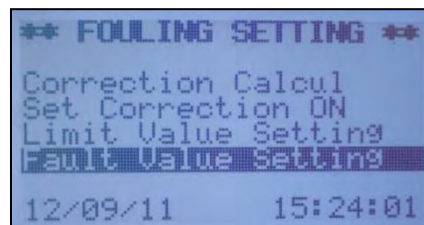

5.5.2 – Adjustment of 4-20mA outputs

From the menu "OTHERS SETTINGS", choose the sub-menu "4-20mA SETTING" using the buttons ↑ or ↓ and confirm with **OK**.

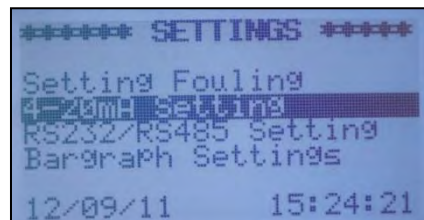

The sub-menu "4-20mA SETTING" is displayed.

Choose the 4-20mA to be set using the buttons ↑ or ↓ and confirm with **OK**.

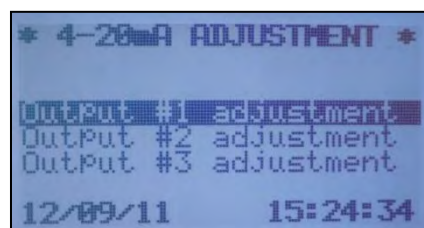

Configuration of the chosen 4-20mA output is displayed :

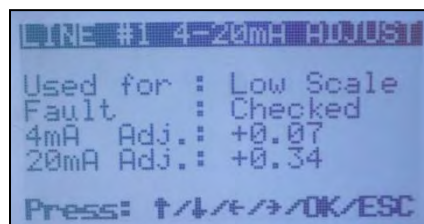
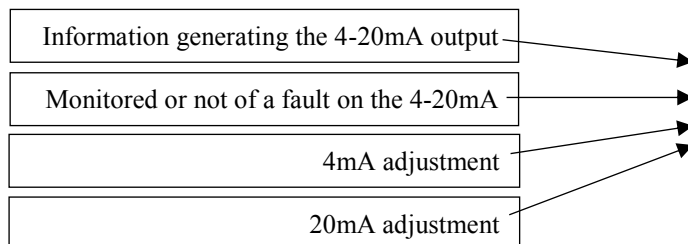

Choose the element to be modified using ↑ or ↓, and press the button → or ← to increase or decrease the value of the selected parameter.

Press **OK** to validate the modified value.

Data generating the 4-20mA output:

The 4-20mA output can be allocated to

- the value measured on the low scale
- the value measured on the high scale
- the fouling value measured

Position onto this line using ↑ or ↓, and press → or ← to choose the data generating the 4-20mA signal.

Monitoring or not of a fault on the 4-20mA signal :

If a fault on the 4-20mA output is detected (line open, weak signal, fuse open), an indicator lamp lights-up on the front. If the choice "Faults" is set to "Monitored", the fault will actuate an alarm and activate the "Fault" relay.

Position onto this line using ↑ or ↓, and press → or ← whether to signal or not 4-20mA output fault by the "fault" relay.

4mA and 20mA adjustment :

In order to adapt the 4-20mA output of the ZFDM-4 to the system acquisition measure, here it is possible to offset the 4mA and 20mA.

Position onto the line required using the buttons ↑ or ↓, then press buttons → or ← to increase or decrease the 4mA or 20mA output of the 4-20mA.

The signal is immediately passed on to the selected output.

5.5.3 – Adjustment of the serial connection

From the "OTHERS SETTINGS" menu, choose the sub-menu "RS232/RS485 Setting" using ↑ or ↓ and confirm with **OK**.

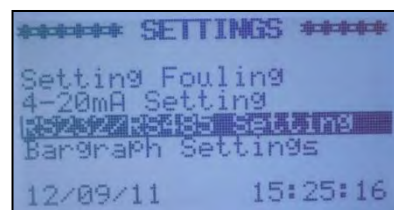

The sub-menu "RS232/RS485 Setting" is displayed.

Select the series connection speed from 300 to 38400 bauds using → or ← and confirm with **OK**.

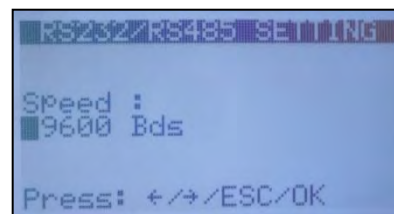

5.5.4 – Bargraph setting

From the "OTHERS SETTINGS" menu, choose the sub-menu "BARGRAPH SETTING" using ↑ or ↓ and confirm with **OK**.

The bargraph setting menu is displayed.

It is possible to choose :

- the bargraph display time period (horizontal 'X' axis) from 1 point per second (visualisation over 20mn) to 1 point every 12 mn (visualisation over 24h)
- the amplitude of the bargraph display (vertical 'Y' axis) High or low scale
- the type of bargraph display Bargraph full or curve

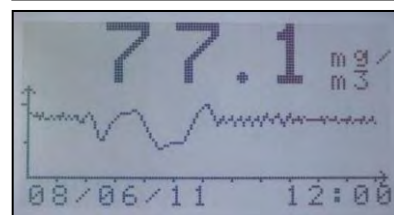
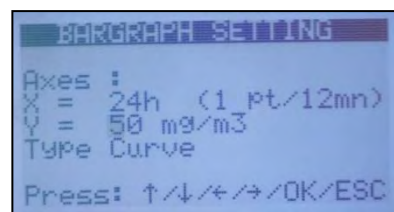

Choose the element to be modified using ↑ or ↓, and press the button → or ← to increase or decrease the value of the selected parameter. Press **OK** to confirm.

5.5.5 – Averaging measurements

In order to smooth the measures, it is possible to make an "averaging" of 1 to 120 seconds per 1 second steps. The measurement displayed is then the rolling average of measurements made over the chosen period.

From the "OTHERS SETTINGS" menu, choose the sub-menu "MEASUREMENT AVERAGE" using ↑ or ↓ and confirm with **OK**.

The sub menu is displayed.

Choose the period required using the buttons → or ← and confirm with **OK**.

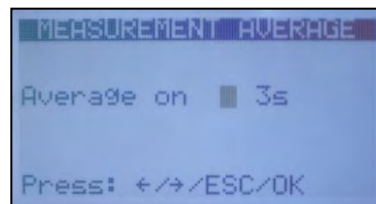
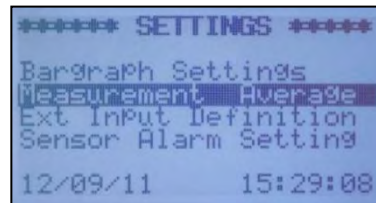

5.5.6 – Measurement offset

In situations of difficult measure (small diameter flue, flue lining reflective or light, etc ...), it may be a reflection of stray light induces an offset of measurement (measuring different from 0 without dust).

In this case, an adjustment of the offset should be made to cancel the disturbance using the sub-menu "Others Settings" - "Measurement Offset"

From the menu "OTHERS SETTINGS", select the submenu "Measurement offset" using ↑ or ↓ and confirm with **OK**.

A sub-menu appears and offers:

- To set ON or OFF the correction
- A manual offset setting
- An automatic calculation of the correction

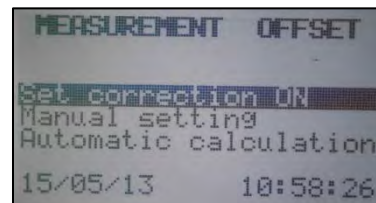

If it is possible to stop the installation so that the emitted dust is zero, select "Manual setting" menu with ↑ or ↓ key and confirm with **OK**

The setup menu is displayed with offset:

- The display of the current measurement →
- The shift to achieve →
- The correction to be made →
- The result →

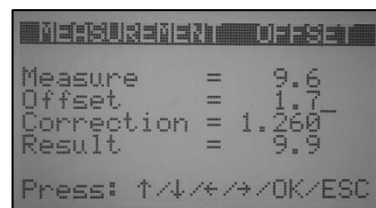

After pre-calibrated unit under subsection 5.3.1 on page 22, the operation consists in:

- Installation stopped, cancel any offset displayed in the line "Measure" by entering the value on line "Offset"
- Restart the installation and adjust the correction coefficient of the line "Correction" to display the correct value on the line "Result" corresponding to the current value of dust.

With ↑ or ↓, select the parameter "Offset" or "Correction" to modify and adjust the value using the keys → or ←
Once finished, press **OK** to confirm.

If it is impossible to stop the installation, or the emitted dust is still present even installation stopped, it is then necessary to know two reference measurements to adjust the offset.

Choose in this case the "Automatic Calculation" menu with \uparrow or \downarrow keys, confirm with **OK**.

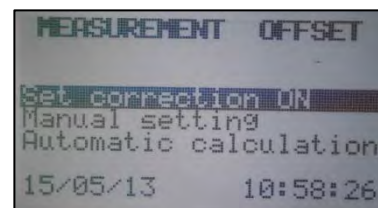

The menu offset calculation appears and offers to enter two real values of dust rejected, and two corresponding values displayed by the ZFDM-4.

With \uparrow or \downarrow keys choose the values to change and adjust this value using the keys \rightarrow or \leftarrow .

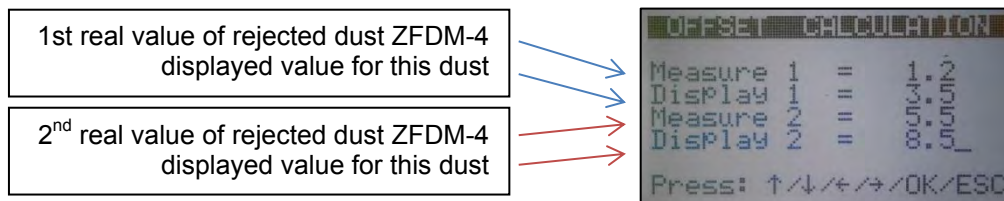

Once finished, press **OK** to calculate the correction.

Refer to Appendix 10.6 on page 39 for more information on the calculation of the correction.

When the correction has been calculated, it is possible to set it ON or OFF.

Choose in these cases the "Set Correction ON" (if the correction is not applied) or "Set Correction OFF" (if the correction is being applied) option using \uparrow or \downarrow keys, confirm with **OK**.

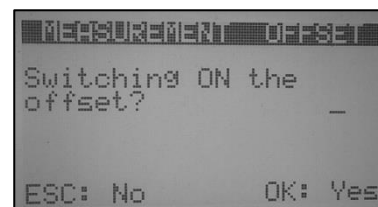

A page will appear offering to turn on or off (depending on the state) the offset by pressing **OK**.

5.5.7 – Sensor alarm adjustments

The fibre optic's sweeping air can be heated in order to avoid the formation of condensation in the sensor.

A heating resistor of 500W is used, for which the temperature is monitored:

- a low temperature alarm activates the fault relay
- the operating temperature range of the resistor is defined by a low and high control temperature
- power supply of the resistor will be cut off if the pressure of the sweeping air is below the set pressure, an alarm (fault relay) will be generated if the pressure of the sweeping air is beyond the defined range.

These parameters can be modified in the "SENSOR ALARM SETTING" menu, which can be selected using the \uparrow or \downarrow buttons from the "OTHERS SETTINGS" menu.

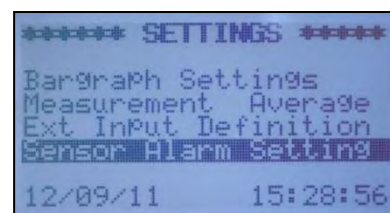

Choose the element to be modified using \uparrow or \downarrow and modify the values using \rightarrow or \leftarrow .

Press **OK** to confirm.

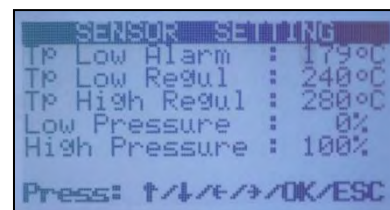

It is possible to adjust the measure of the sensor's low and high pressure sweeping air to adapt to the pressure present in the duct:

Position onto the line "Low pressure" using \uparrow or \downarrow and press \rightarrow or \leftarrow .

Press **OK** when the message 'AUTO Pressure set. ?', is displayed and follow the indications indicated :

- Adjust the pressure distributed to the sensor to the minimum value required and press **OK**. The minimum pressure is measured.
- Adjust the pressure to the maximum value required and press **OK**. The maximum pressure is measured.
- The unit is adjusted.

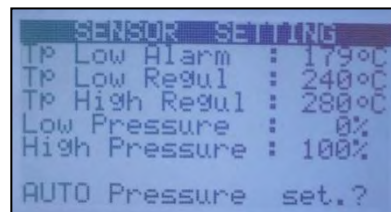

5.5.8 – Threshold hysteresis

Hysteresis on a threshold relay trip can be defined.

From the "OTHERS SETTINGS" menu, choose the sub-menu "THRESHOLD HYSTERESIS" using \uparrow or \downarrow and confirm with **OK**.

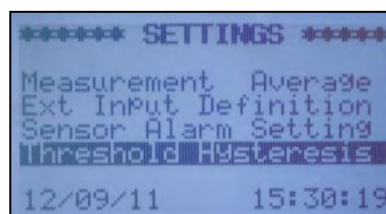

The sub-menu displays.

Choose the hysteresis required using \rightarrow or \leftarrow and confirm with **OK**.

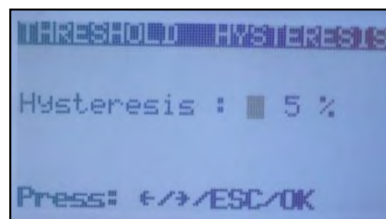

5.5.9 – Adjusting the time and date

From the "OTHERS SETTINGS" menu, choose the sub-menu "DATE AND TIME SETTING" using \uparrow or \downarrow and confirm with **OK**.

The time and date are then displayed.

Press the \rightarrow or \leftarrow buttons to navigate in the various elements and adjust using the \uparrow or \downarrow buttons.

Confirm with **OK**.

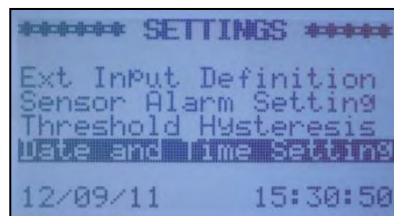

5.5.10 – Language display

From the "OTHERS SETTINGS" menu, choose the sub-menu "DISPLAY LANGUAGE" using \uparrow or \downarrow and confirm with **OK**.

The choice of languages is either French or English.

Press the \rightarrow or \leftarrow button to choose the language and confirm with **OK**.

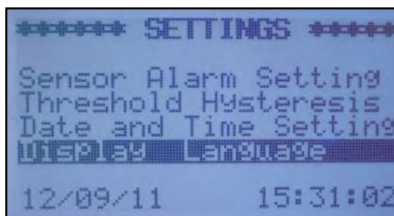

5.5.11 – Other adjustments (Reserved for Fuji Electric)

Other settings are available for Fuji Electric staff but are only accessible by a password because the changes may result in the faulty operation of the device.

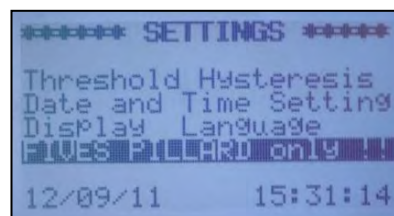

6 – COMMISSIONING

6.1 – First commissioning

After mounting the sensor and the electronic unit according to the recommendations of paragraph 3:

- Check the correct insertion of optical fibers in their placements of the cabinet (see §3.2.3 page 15)
- Check the position of the switch S2 matches the supply voltage
- Check compliance of all connections
- Turn the power on by positioning the switch S1 to ON
- If necessary, adjust the contrast of the LCD display via the potentiometer P1
- Make a "Light Setting":
 - Go to Menu 'Others Settings' menu and then 'Maintenance'
 - An access code is requested: enter 4 times the button 'Down Arrow'
 - Choose the menu "Light Setting"
 - Press the 'OK' to confirm
 - The setting starts
 - Press the 'OK' to save

6.2 – First Setting

- Go into the "CONFIGURATION" menu
- Enter the units and measuring scales
- Check that the type of sensor (heated or not) is correctly selected
- If necessary adjust the time and date ("Others Settings" Menu)
- Set the 4-20mA output ("Others Settings" Menu)
- Go into the Calibration menu and select 'Pre-Calibration'
- See paragraph 5.3.1 to pre-calibrate the unit
- Refer to paragraph 5.5.1.2 to set the fouling zero

Thereafter, you can:

- Enter threshold values ("Configuration" Menu)
- Set the relays
- Change the smoothing time of the measurement
- ...

7 – CALIBRATION EXAMPLE

Example : An installation for which the average known concentration of dust is 20mg, with values which can reach up to 500mg due to filtering faults.

We want a low measurement scale from 0 to 50 mg, a high level of 500 mg, an alarm if the measure exceeds 70 mg.

Settings:

- CONFIGURATION Menu
 - Low Scale = 50mg
 - High Scale = 500mg
 - Threshold value 1 : 70mg
 - Threshold type 1 : ' > '
 - Relay 1 = Threshold 1

- OTHERS SETTINGS Menu
 - 4-20mA output n° 1 : Low scale
 - 4-20mA output n° 2 : High scale
- CALIBRATION Menu
 - Pre-calibration : display 20mg (see paragraph 5.3.1)

The ZFDM-4 is now pre-calibrated.

Final Calibration:

- Ask an approved official body to carry out a weight measurement
- During the time that the official body carries out its sampling measurements, note the value displayed by the ZFDM-4.
- When the official body gives the measurement of its sample , it suffices to select the option '**Weight measurement option**' form the **Calibration** menu and to enter the two measuring values (approved body and ZFDM-4)
- Initiate a new calibration by pressing **OK**

The ZFDM-4 is now definitively calibrated for the corresponding type of dust.

8 – MAINTENANCE

The ZFDM-4 requires very little maintenance. It does however need a periodic check which comprises verifying:

- The general condition of the wiring in the panel,
- The clean condition of the electronic circuits (tensioned-dusting when shut-down),
- The clean condition of the fibre optics,
- The condition of the panel door seal.

8.1 – Cleaning the fibre optic tips on the sensor side

For this, use a rag without any solvent.

This simple and quick operation can be carried out without shutting down the ZFDM-4. It is recommended to block the measure during this operation. (see paragraph 5.2)

8.2 – Cleaning the sensor unit

Every six to twelve months, remove the fibre optics and dismantle the sensor to clean the sensor's flue gas side face with a metal brush.

8.3 – Drift monitoring

Place the "clean" fibre optics in the calibration control unit.

Select the option '**Checking**' in the '**Calibration**' menu.

The display then indicated the theoretical value and the measured value on the control unit.

In the case where the difference is judged to be too great, it is sufficient to just press **OK** to restart a unit calibration.

9 – SPARE PARTS

Designation	Reference	Lifetime ⁽¹⁾
Led emission unit	P-275389	30000 h
Fuse set (10 fuses 5x20 3.15AT, 10 fuses 5x20 1AT, 10 fuses MSF250 0.125A)	FU-4000	(²)
Calibration control unit (1 position)	P-282666	
Calibration control unit (4 positions)	P-402262	
Transmitter fibre optic length 1,2 m	Z-279185	(³)
Transmitter fibre optic length 2,2 m	Z-279194	(³)
Receiver fibre optic length 1,2 m	Z-233620	(³)
Receiver fibre optic length 2,2 m	Z-233621	(³)
Transmitter/Receiver unit	P-275393	(⁴)
Main circuit	CP-4000	(⁴)
Sensor	P-281096	(³)
Air heater (for heated sensor)	P-253634	(³)

(¹) Average lifespan (in normal use following the recommendations in this leaflet)

(²) Primary emergency part it is necessary to have in stock

(³) Wear part for when operating in difficult environments

(⁴) Part to have in stock in the case where no shut-down, of a minimum time corresponding to the repair time (4 weeks ex-works) can be tolerated.

Nota : To order any spare parts, please
always include our registration number and the
circuits or component reference, and the units number

10 – ANNEXES

10.1 – Position of the switches and terminals on the main board

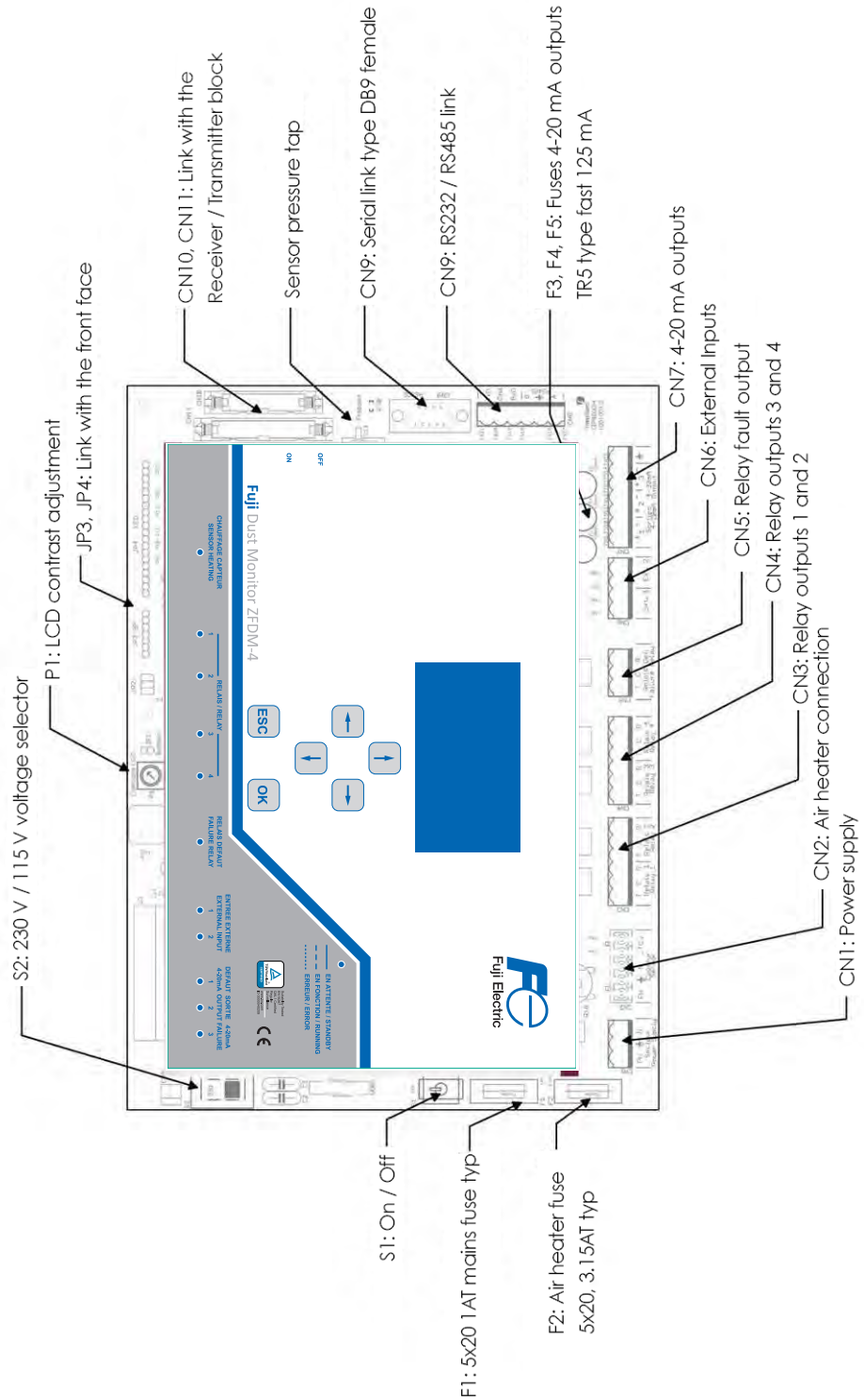

Figure 17 - Main printed circuit CP-4000

10.2 – Calibration control unit

The measurement principle of the Fuji ZFDM-4 is to recover the light transmitted by an emitting fibre optic reflected by airborne particles on a 'receiving' fibre optic positioned at 90 degrees. The intensity of the light received is much less than that emitted and is proportional to the amount of dust between the two fibre optics.

To check the ZFDM-4 calibration, a 'calibration control unit' is used, in which are housed the transmitter and receiver fibre optics, facing each other, an optical filter is positioned between them to reduce the transmitted light and simulate the light reflected by particles

The process of ZFDM-4 calibration consists in comparing the values obtained with the calibration unit with the attenuation from particles to be measured.

Once the ratio of these two attenuations is known and memorised in the ZFDM-4, for example during a weight measurement, the device can then be re-calibrated thanks to the the calibration control unit.

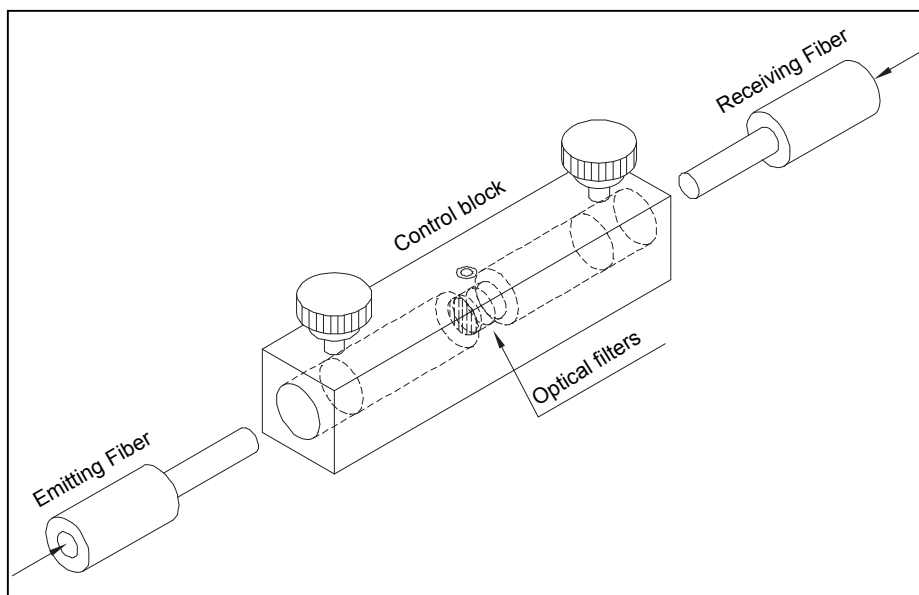
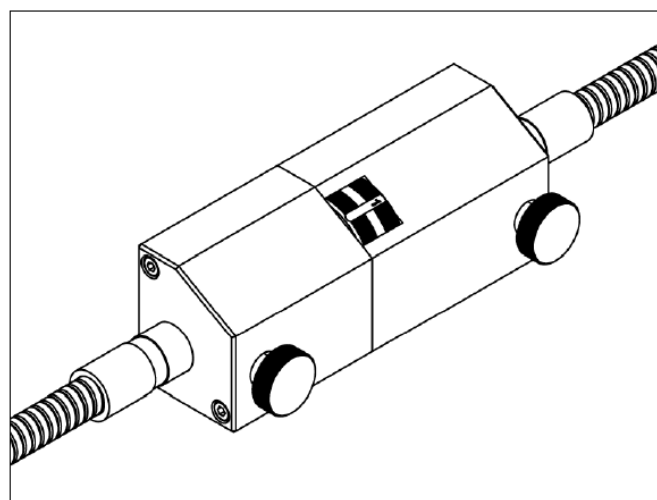

Figure 18 - Calibration control unit (1 position)



"Figure 18b -Calibration control unit
(4 positions : 3 calibration values and 1 "zero" position)"

10.5 – Problems / Solutions

In the case of a fault on the unit, the status lamp (see figure 3) flashes rapidly and the fault is displayed on the last line of the LCD.

The possible messages are:

Light control fault:

- 'Light Ctrl Fault': Fault on the light emission control
- 'High Led Current': Led emission current too strong
- 'Fault Light Rtrn': No measure on the regulation of emitted light
- 'Plum Val. Limit': Value at adjustment limit for light emission control

Faults concerning sweeping air:

- 'Tp Sensor Low': Air heater temperature too low
- 'Sensor Press low': Sweeping air pressure in the sensor too low
- 'Sensor Press Hgh': Sweeping air pressure in the sensor too strong
- 'Thermocple Fault': Sweeping air Thermocouple Fault

Aquisition monitoring fault:

- 'Err. 0 Low Scale': Monitoring fault zero value of the low scale measure
- 'Err Max Lo Scale': Monitoring fault maximum value of the low scale measure
- 'Err 0 High Scale': Monitoring fault zero value of the high scale measure
- 'Err Max Hi Scale': Monitoring fault maximum value of the high scale measure

Faults on the 4-20mA outputs:

- '420mA Line Fault': Fault on the 4-20mA output current

Information Messages:

- 'Fouling Max': Fouling measured at maximum level
- 'Value Locked': the measure is locked (or fixed)

10.5.1 – Display of the control fault of the light emitted

A light control fault can be translated from the messages 'Light Ctrl Fault', 'High Led Current', 'Fault Light Rtrn' or 'Plum Val. Limit'

Problem : The electronics can't control the emitted light.

Solutions :

- Check that the fibre optic is properly lodged in its housing
- Check that a light is indeed emitted from the tip of the transmitting fibre optic (sensor side)
- In the 'Information' window, go to 'LED' EMISSION INFO, note the information displayed and contact our after-sales service.

10.5.2 – Display of the fault 'Thermocouple fault'

Problem : The thermocouple is not detected by the control system for the sweeping air temperature

Solutions :

- Check the thermocouple connection (+ = red wire, - = blue wire)

10.5.3 – Display of a fault 'Tp Sensor low'

Problem : Sweeping air heater resistance temperature is too low.

Solutions :

- Check that the 'Heating Sensor' signal lamp on the front is lit and the power supply is available at the terminals of PH and N of connector CN2)
- If the ZFDM-4 has just been energised. Wait 15 minutes for the sensor to have time to heat
- The flow of sweeping air is too high. The sensor cannot take its temperature. Comply with the recommended pressure and flow rate (400 mbar, 2 Nm³/h)
- The power supply voltage of the heating resistor does not match. Check the voltage specified on our delivery note (230V ~ or 115V ~) and the voltage across the CN2 connector (Output Sensor, points PH and N)
- Check the connection of the thermocouple (+ = red wire, - = blue wire)

10.5.4 – Display of a sweeping air fault

The fault message could be '**Sensor Press low**' or '**Sensor Press Hgh**' .

Problem : The pressure measured for the sweeping air is not correct.

Solutions :

Check that the sensor does have an internal pressure tapping, and the pressure intake pipe is connected and not pinched.

The pressure of the sweeping air is not in conformity (inadequate or in excess). Comply with the recommended pressure and flow rate (400 mbar, 2 Nm³ / h)

In the menu 'Information', section 'INFORMATION SENSOR' check the values measured and do a calibration of the pressure measurement if necessary (menu 'Miscellaneous Settings' under 'Settings ALRM sensor'. If no pressure tapping is present, check the type of sensor selected from the Setup menu: the type should be 'cold', 'TC', or '-TC - PSL' to not test pressure.

If the airflow is sufficient, make sure the flue duct is under a strong depressurisation. If a calibration of the pressure tap is not possible, disconnect the sensor's pressure tapping and select a sensor type without pressure tapping ('TC' or 'TC- PSL-' depending on the presence or absence of the thermocouple).

10.5.5 – Display of an acquisition monitoring fault

The fault message could be '**Err. 0 Low Scale**', '**Err Max Lo Scale**' , '**Err 0 High Scale**' or '**Err Max Hi Scale**' .

Problem : The ZFDM-4 checks every day from 00h00 the 2 acquisition measuring chains (low and high scale). If a fault is detected, an alarm is generated.

Solutions :

Note the message displayed and contact our after-sales service.

10.5.6 – Display of the fault ' 420mA Line Fault'

Problem : A 4-20mA output current has its connection open. A red signal lamp lights up on the front face for the output concerned.

Solutions :

- Check the connections of the 4-20mA concerned
- Check the fuse status for the 4-20mA output concerned (F3 to F5 for output 1 to 3, fuse type TR5-F 125mA.
- If the 4-20mA output is not used, set it to 'NOT USED' in the menu miscellaneous settings, unit 4-20mA settings).

10.5.7 – Display of the fault 'Value Locked'

Problem : The measure has been locked (or fixed) by the operator in the menu 'Locking Measure/Alarm'

Solutions :

- Reposition the value to ' Normal processing' in the menu 'Locking Measure/Alarm' as soon as possible.

10.6 – Measurement offset

In situations of difficult measure (small diameter flue, flue lining reflective or light, etc ...), it may be a reflection of stray light induces an offset of measurement (measuring different from 0 without dust).

In this case, an adjustment of the offset should be made to cancel the disturbance using the submenu "Others Settings" - "Measurement Offset".

If we have two reference measurements, far enough away to have maximum accuracy, we can calculate the correction to be made to cancel the effect of the offset.

If a measure of dust "Dust_A" is displayed by the ZFDM-4 as "Display_A" and a second measurement "Dust_B" is displayed as "Display_B", we can calculate a correction curve:

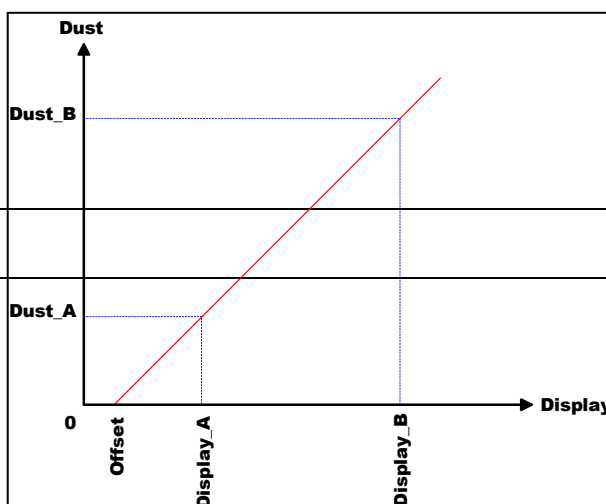

$$\text{Dust} = \text{Coef_Correcteur} \times \text{Display} - \text{Offset}$$

Application :

$$\text{Dust}_A = \text{Coef_Correcteur} \times \text{Display}_A - \text{Offset} \quad \textcircled{1}$$

$$\text{Dust}_B = \text{Coef_Correcteur} \times \text{Display}_B - \text{Offset} \quad \textcircled{2}$$

$$\textcircled{2} - \textcircled{1} \rightarrow \text{Coef_Correcteur} = (\text{Dust}_B - \text{Dust}_A) / (\text{Display}_B - \text{Display}_A)$$

$$\textcircled{2} \rightarrow \text{Offset} = \text{Coef_Correcteur} \times \text{Display}_B - \text{Dust}_B$$

Example: If we have a display on the ZFDM-4 of 3.5mg (Display_A) when the dust rejected is 1.2mg (Dust_A), and a display of 8.5mg (Display_B) when the dust rejected is 5.5mg (Dust_B), we can deduce the correction curve:

$$\text{Coef_Correcteur} = (5.5 - 1.2) / (8.5 - 3.5) = 4.3 / 5.0 = 0.86$$

$$\text{Offset} = (0.86 \times 8.5) - 5.5 = 1.8$$

- In the "Measurement offset" - "Manual setting" menu, enter 1.8 in the line "Offset" and 0.86 in the line "Correction".

OR

- In the "Measurement offset" – "Automatic calculation" menu, enter the appropriate values.

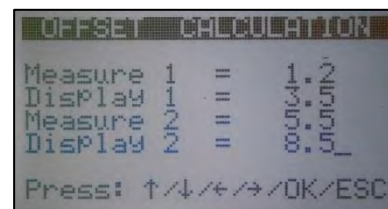
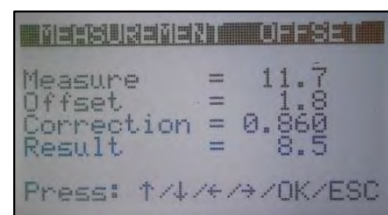

11 – "High Temperatures" option

For smoke temperatures above 350 ° C, the "FFP-205404" cooling box must be used.

This replaces the support for the sensor of the ZFDM-4 and is therefore inserted between the sensor and the chimney flue.

The air inlet of the sensor and the two air inlets of the cooling unit are supplied by compressed air, with a pressure of 0.5 to 0.7 bar for the sensor, and between 0.8 and 1 bar for the cooling box, depending on the smoke temperature (between 500 and 800 ° C).

Assembly / Connections:

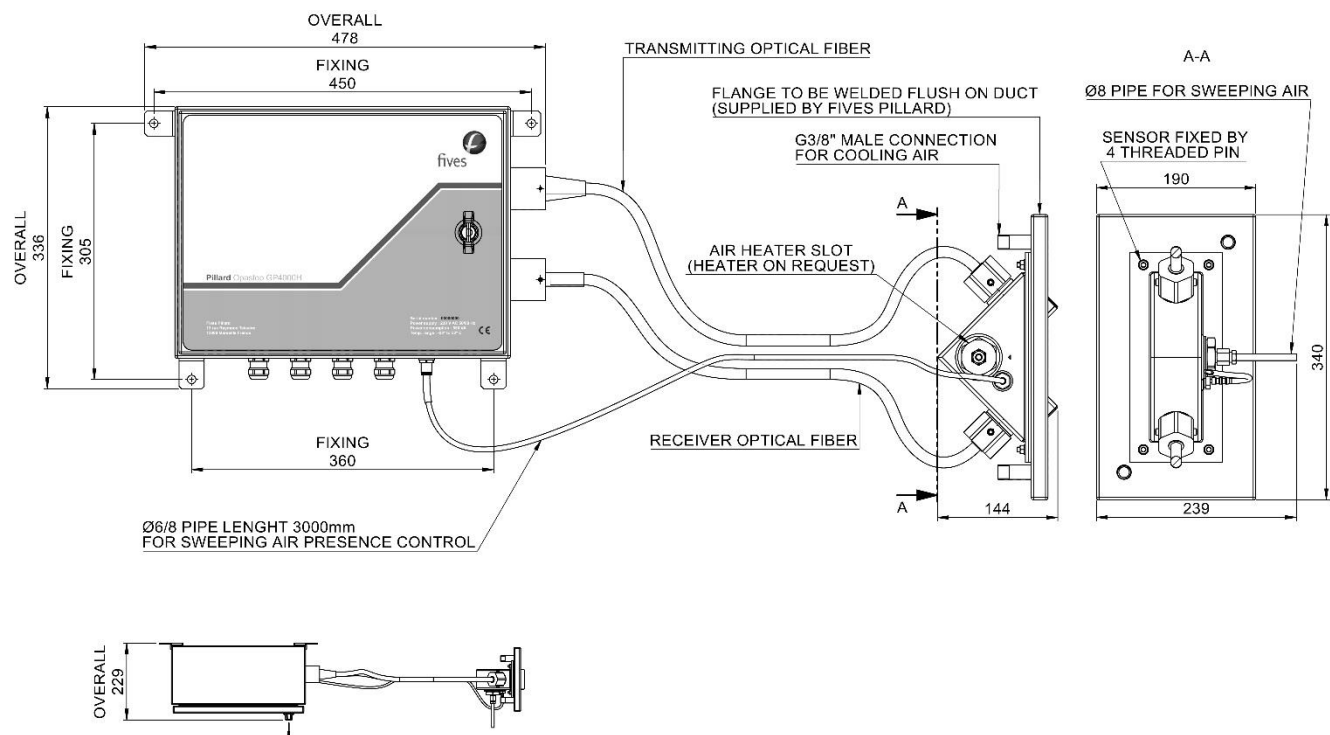

LENGTH OF STANDARD OPTICAL FIBER:
 OVERALL: 2200mm
 2000mm BETWEEN ELECTRONIC CABINET AND SENSOR

Settings:

- Remove the fibers from the sensor nozzles.
- Ensure that the production line is running (nominal load) and that the flue gas temperature is such that in normal operation (maximum estimated).
- Connect the 2 air intakes of the cooler and the air intake at the sensor.
Adjust the pressure on the cooler between 0.8 and 1bar and between 0.5 and 0.7bar the pressure on the sensor. The pressure setting depends on the flue gas temperature, low pressure if the temperature is around 500 ° C or high pressure if the temperature is up to 800 ° C.
- Check the mounting of the air inlets on the cooling flange and on the sensor with a "gazon" type product (leak tester).
- Take a temperature measurement by inserting a thermocouple in one of the sensor nozzles. Block the nozzle openings with a cloth during the measurement to be more representative of reality.
- Adjust the pressure on the cooler first to adjust the settings, then refine with the pressure on the sensor to obtain a temperature at the nose of the nozzles between 180 ° C and 220 ° C.
- After blocking the nozzle openings, go to the information menu and view the sensor heating temperature. This must oscillate between 180 ° C and 200 ° C with a rapid drop in temperature when the power supply to the heating resistor is cut by the TOR system and a gradual rise thereafter.
- Insert one fiber then the other in their housings while controlling the temperature of the sensor in the information menu.
- Check the condition of the optical fibers in the next 24 and 48 hours.



Fuji Electric France S.A.S.

46, Rue Georges Besse - Z I du Brézet - 63 039 Clermont-Ferrand cedex 2 FRANCE

France : Tél. 04 73 98 26 98 - Fax 04 73 98 26 99 - International : Tél. (33) 4 7398 2698 - Fax. (33) 4 7398 2699

E-mail : sales.dpt@fujielectric.fr – WEB : www.fujielectric.fr

Fuji Electric can accept no responsibility for possible errors in catalogues, brochures and other printed material. Fuji Electric reserves the right to alter its products without notice. This also applies to products already on order provided that such alterations can be made without sub sequential changes being necessary in specifications already agreed. All trademarks in this material are property of the respective companies. All rights reserved.