



---

**Service Manual**

---

**COMPACT TYPE  
GAS ANALYZER**

**TYPE: ZSVF  
ZSVS**

---

# PREFACE

---

This service manual for the compact type gas analyzer (type ZSVF, ZSVS) describes the factory mode for maintenance and inspection, method of adjustment to be performed after parts replacement, and measures to be taken in case of occurrence of troubles.

The manual does not describe basic operations of the gas analyzer. Be sure to read the manual carefully before performing maintenance and inspection.

This service manual gives you useful hints to take immediate remedy for after-sales service.

- First read the instruction manual and service manual carefully until an adequate understanding is acquired, and then proceed to installation, operation and maintenance of the gas analyzer. Wrong handling may cause an accident or injury.
- The specifications of this gas analyzer will be changed without prior notice for further product improvement.
- Modification of this gas analyzer is strictly prohibited unless a written approval is obtained from the manufacturer. Fuji Electric will not bear any responsibility for a trouble caused by such a modification.

Manufacturer: Fuji Electric Co., Ltd.  
Type: Described in the nameplate on main frame  
Date of manufacture: Described in the nameplate on main frame  
Product nationality: Japan

## Request

- It is prohibited to transfer part or all of this manual without Fuji's permission in written format.
- Description in this manual will be changed without prior notice for further improvement.

©Fuji Electric Co., Ltd.

Issued in June, 2006  
Rev. 1st edition April, 2011

---

# CONTENTS

---

PREFACE.....	i
CAUTION ON SAFETY .....	iv
1. NAME OF MAIN DEVICES AND SERVICE PARTS .....	1
1.1 Analyzer unit .....	1
1.1.1 Analyzer unit (ZSVF).....	1
1.1.2 Analyzer unit (ZSVS).....	2
1.2 Measurement unit .....	3
1.3 Sampling unit.....	5
2. MAINTENANCE, INSPECTION, AND ADJUSTMENT AFTER REPAIR AND REPLACEMENT .....	7
2.1 Analyzer unit .....	7
2.1.1 Display unit .....	7
2.1.2 Membrane switch .....	8
2.1.3 Power supply .....	9
2.1.4 Amplifier printed circuit board.....	10
2.1.5 Control printed circuit board .....	11
2.1.6 Main printed circuit board.....	13
2.1.7 Power switch .....	14
2.2 Measuring unit.....	15
2.2.1 Light source unit.....	15
2.2.2 Cell, cell window and O-ring (common to block cell and pipe cell).....	17
2.2.3 Detector (other than O <sub>2</sub> sensor) .....	18
2.2.4 Gas filter .....	20
2.2.5 Oxygen sensor .....	21
2.3 Sampling unit.....	22
2.3.1 Power supply .....	22
2.3.2 Exhaust fan unit.....	22
2.3.3 Electric dehumidifier .....	23
3. FACTORY MODE .....	24
3.1 How to go to Factory Mode.....	24
3.2 How to go to each item in Factory Mode .....	25
3.3 Setting item in Factory Mode .....	26
3.3.1 PILC code.....	26
3.3.2 Language setting .....	27
3.3.3 Number of channels (Measured component setting).....	28
3.3.4 Channel parameter (setting of range and unit) .....	30
3.3.5 Zero offset .....	31
3.3.6 Linearizer .....	32
3.3.7 Temperature compensation.....	33
3.3.8 O <sub>2</sub> adjustment .....	36
3.3.9 Output selection.....	38
3.3.10 Output adjustment .....	39
3.3.11 Interference compensation.....	40

3.3.12	Memory rewrite .....	42
3.3.13	Coefficient confirmation .....	44
3.3.14	A/D data .....	45
3.3.15	Component display setting .....	46
4.	ERROR JUDGEMENT CRITERIA FOR ERROR CODES .....	47
5.	COUNTERMEASURES AGAINST TROUBLE .....	48
6.	ADJUSTMENT IN HEAT TREATMENT FURNACE .....	50
7.	MEASURING PRINCIPLE DIAGRAM .....	52
8.	SOFT FLOW CHART .....	53
9.	INTERNAL WIRING DIAGRAM .....	54
9.1	Analyzer unit .....	54
9.1.1	Analyzer unit (ZSVF) .....	54
9.1.2	Analyzer unit (ZSVS) .....	55
9.2	Sampling unit .....	56
10.	INTERNAL PIPING .....	57
10.1	Analyzer unit .....	57
10.1.1	Analyzer unit (ZSVF) .....	57
10.1.1.1	System 1 .....	57
10.1.1.2	System 2 .....	58
10.1.1.3	System 1 with O <sub>2</sub> .....	59
10.1.1.4	System 2 with O <sub>2</sub> .....	60
10.1.2	Analyzer unit (ZSVS) .....	61
10.1.2.1	System 1 .....	61
10.1.2.2	System 2 .....	62
10.2	Sampling unit .....	63
10.2.1	Outlet 1 system (1-component or 2-component meter excluding NO <sub>x</sub> meter) .....	63
10.2.2	Outlet 2 system (2-component to 4-component meter excluding NO <sub>x</sub> meter) .....	64
10.2.3	Outlet 1 system (1-component or 2-component meter including NO <sub>x</sub> meter) .....	65
10.2.4	Outlet 2 system (2-component to 4-component meter including NO <sub>x</sub> meter) .....	66
11.	PRINTED CIRCUIT BOARD DIAGRAM .....	67
11.1	Amplifier printed circuit board at analyzer unit .....	67
11.2	Control printed circuit board at analyzer unit .....	67
11.3	Main printed circuit board at analyzer unit .....	68

---

# CAUTION ON SAFETY

---

**First of all, read this “Caution on safety” carefully, and then use the gas analyzer in the correct way.**

The cautionary descriptions listed here contain important information about safety, so they should always be observed. Those safety precautions are ranked in 2 levels, “DANGER” and “CAUTION.”



## DANGER

Wrong handling may cause a dangerous situation, in which there is a risk of death or heavy injury.



## CAUTION

Wrong handling may invite a dangerous situation, in which there is a possibility of medium-level trouble or slight injury or only physical damage is predictable.

### Caution on installation and transport of gas analyzer



## DANGER

- This unit is not explosion-proof type. Do not use it in a place with explosive gases to prevent explosion, fire or other serious accidents.



## CAUTION

- Install the gas analyzer in a place that satisfies the conditions described in the “Instruction Manual.” Otherwise electric shock, fire, or malfunction may result.
- During maintenance and check, care should be taken to keep the unit free from cable chips or other foreign objects. Otherwise, it may cause fire, trouble or malfunction of the unit.
- For lifting the gas analyzer, be sure to wear protective gloves. Bare hands may invite an injury.
- The gas analyzer is heavy. Two or more persons should carry the gas analyzer with sufficient care to avoid injury or damage to body.

#### Caution on piping



**DANGER**

**In piping, the following precautions should be observed. Wrong piping may cause gas leakage.**

**If the leaking gas contains a toxic component, there is a risk of serious accident being induced.**

**Also, if combustible gas is contained, there is a danger of explosion, fire or the like occurring.**

- Connect pipes correctly referring to the instruction manual.
- Exhaust should be led outdoors so that it will not remain indoors.
- Exhaust from the gas analyzer should be relieved in the atmospheric air in order that an unnecessary pressure will not be applied to the gas analyzer. Otherwise, any pipe in the gas analyzer may be disconnected to cause gas leakage.
- For piping, use a pipe and a pressure reducing valve to which oil and grease are not adhering. If such a material is adhering, a fire or the like accident may be caused.

#### Caution on wiring



**CAUTION**

- Be sure to perform specified grounding work to avoid electric shock or malfunction.
- Be sure to use a power supply of correct rating. Connection of power supply of incorrect rating may cause fire.
- Wiring work must be performed with the main power set to OFF to prevent electric shocks.
- Wires should be the proper one meeting the ratings of this instrument. If using a wire which cannot endure the ratings, a fire may occur.

#### Caution on use



**DANGER**

- For correct handling of calibration gas or other reference gases, carefully read their instruction manuals beforehand.



**CAUTION**

- Do not operate the gas analyzer continuously with the cover opened. Otherwise dust may enter, causing a failure.
- Do not open the cover and touch inside while the gas analyzer is operated. Otherwise burns or electric shock may result.

### Caution on maintenance and check

## DANGER

- Before performing work with the cover opened, be sure to turn off the power and purge fully not only the gas analyzer but also measurement gas lines with air and N<sub>2</sub> gas. Be careful not to stain the filter and packing with oil or grease. Otherwise gas leak may occur, thus causing poisoning, fire, or explosion.

## CAUTION

- Be sure to remove metallic objects such as a wristwatch or a ring. Never perform work with wet hands to avoid electric shock.
- If the fuse is blown, eliminate the cause, and then replace it with the one of the same capacity and type as before. Otherwise, shock hazard or fault may be caused.

### Others

## CAUTION

- If the cause of any fault cannot be determined despite reference to the instruction manual, be sure to contact your dealer or Fuji Electric's technician in charge of adjustment. If the instrument is disassembled carelessly, you may have a shock hazard or injury.
- Do not use replacement parts not specified by the manufacturer. Otherwise sufficient performance of the gas analyzer may not be obtained, or accidents or failure may result.
- Dispose the parts removed for maintenance as noncombustible waste.

# 1. NAME OF MAIN DEVICES AND SERVICE PARTS

## 1.1 Analyzer unit

### 1.1.1 Analyzer unit (ZSVF)

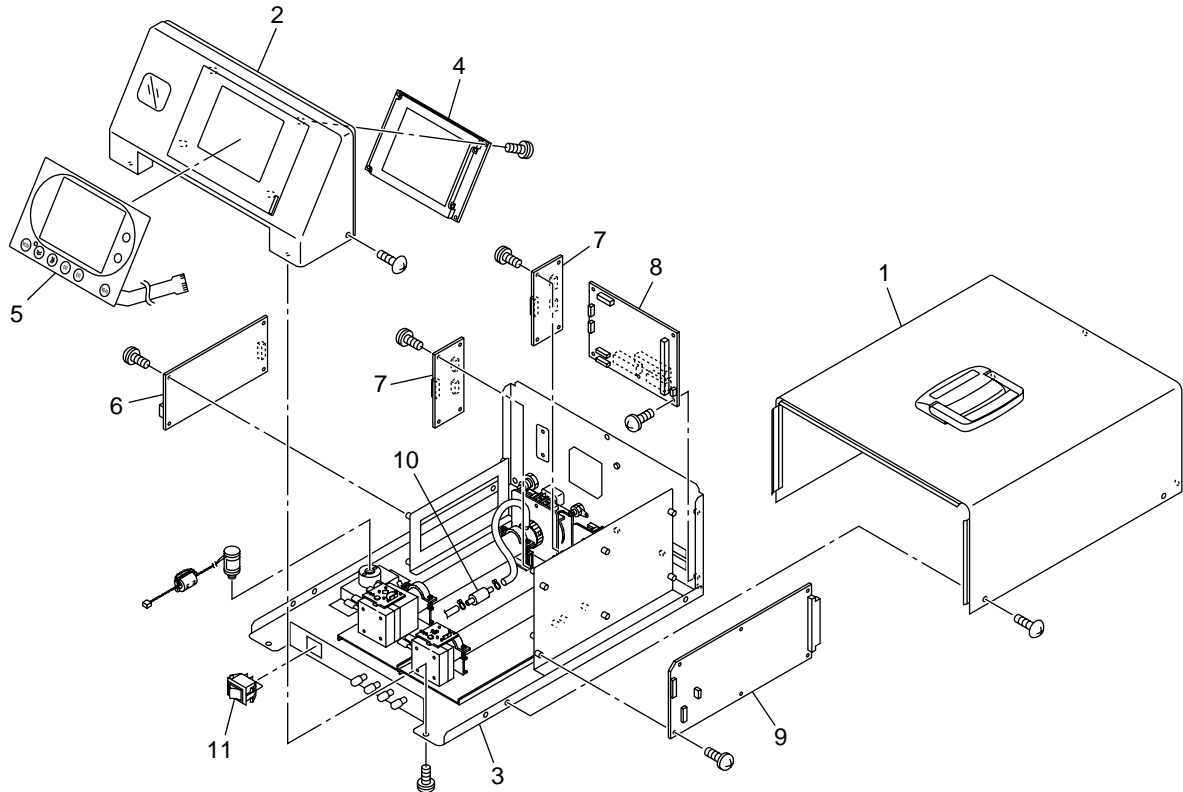

No.	Parts order No.	Parts name	Recommended replacement cycle	Note
1	ZZPZSV1-A030	Cover assembly	—	Handle not included
2	ZZPZSV1-A020	Front panel assembly	—	Window/flow checker not included
3	ZZPZSV1-A010	Base assembly	—	Part not included
4	ZZPZSV1-A280	Display unit	About 5 years (continuous operation)	See Page 7 for replacement procedure.
5	ZZPZSV1-A270	Membrane switch	500,000 times/1 contact	See Page 8 for replacement procedure.
6	ZZPZSV1-A250	Power supply	—	See Page 9 for replacement procedure.
7	ZZPZSV1-A290	Amplifier printed board	—	See Page 10 for replacement procedure.
8	ZZPZSV1-A300	Control printed board	—	See Page 11 for replacement procedure.
9	ZZPZSV1-A310	Main printed board	—	See Page 13 for replacement procedure.
10	ZZPZSV1-B070	Filter	When drain inflow or contamination occurs	See Instruction Manual for replacement procedure.
11	ZZPZSV1-A200	Power switch	Contact: 10,000 times (ON/OFF) Lamp: About 2 years (continuous operation)	See Page 14 for replacement procedure.

Note 1: Specify “Parts order No.” on the list when ordering the parts.

Note 2: The replacement cycle varies depending on use conditions.



## 1.1.2 Analyzer unit (ZSVS)

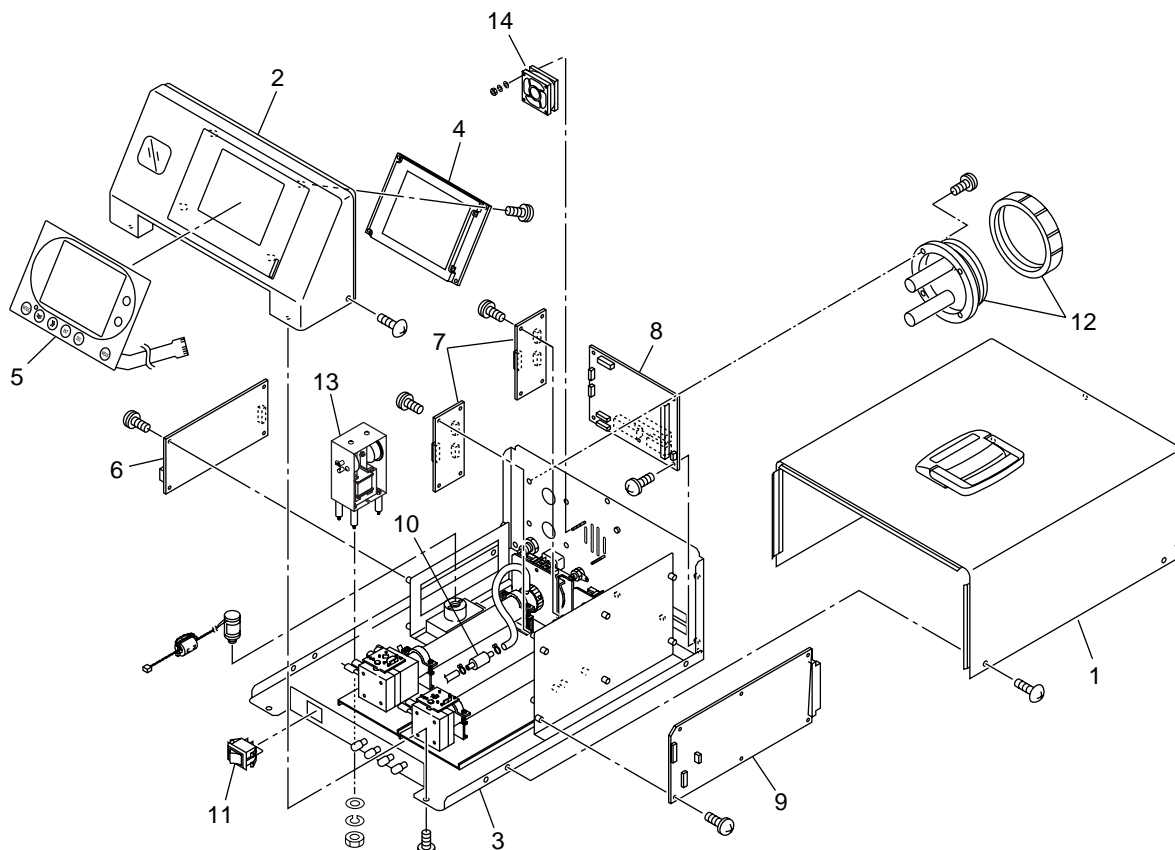

No.	Parts order No.	Parts name	Recommended replacement cycle	Note
1	ZZPZSV1-A030	Cover assembly	—	Handle not included
2	ZZPZSV1-A020	Front panel assembly	—	Window/flow checker not included
3	ZZPZSV1-A010	Base assembly	—	Part not included
4	ZZPZSV1-A280	Display unit	About 5 years (continuous operation)	See Page 7 for replacement procedure.
5	ZZPZSV1-A270	Membrane switch	500,000 times/1 contact	See Page 8 for replacement procedure.
6	ZZPZSV1-A250	Power supply	—	See Page 9 for replacement procedure.
7	ZZPZSV1-A290	Amplifier printed board	—	See Page 10 for replacement procedure.
8	ZZPZSV1-A300	Control printed board	—	See Page 11 for replacement procedure.
9	ZZPZSV1-A310	Main printed board	—	See Page 13 for replacement procedure.
10	ZZPZSV1-B070	Filter	When drain inflow or contamination occurs	See Instruction Manual for replacement procedure.
11	ZZPZSV1-A200	Power switch	Contact: 10,000 times (ON/OFF) Lamp: About 2 years (continuous operation)	See Page 14 for replacement procedure.
12	ZZPZSV1-A750	Membrane filter	Filter paper: About 1 to 2 months	See Instruction Manual for replacement procedure.
13	ZZPZSV1-A720	Pump	Diaphragm: About 1 year	See Instruction Manual for replacement procedure.
14	ZZPZSV1-A200	Fan	40,000 hours	Contact us for replacement procedure.

Note 3: Specify “Parts order No.” on the list when ordering the parts. The replacement cycle varies depending on use conditions.

# 1.2 Measurement unit

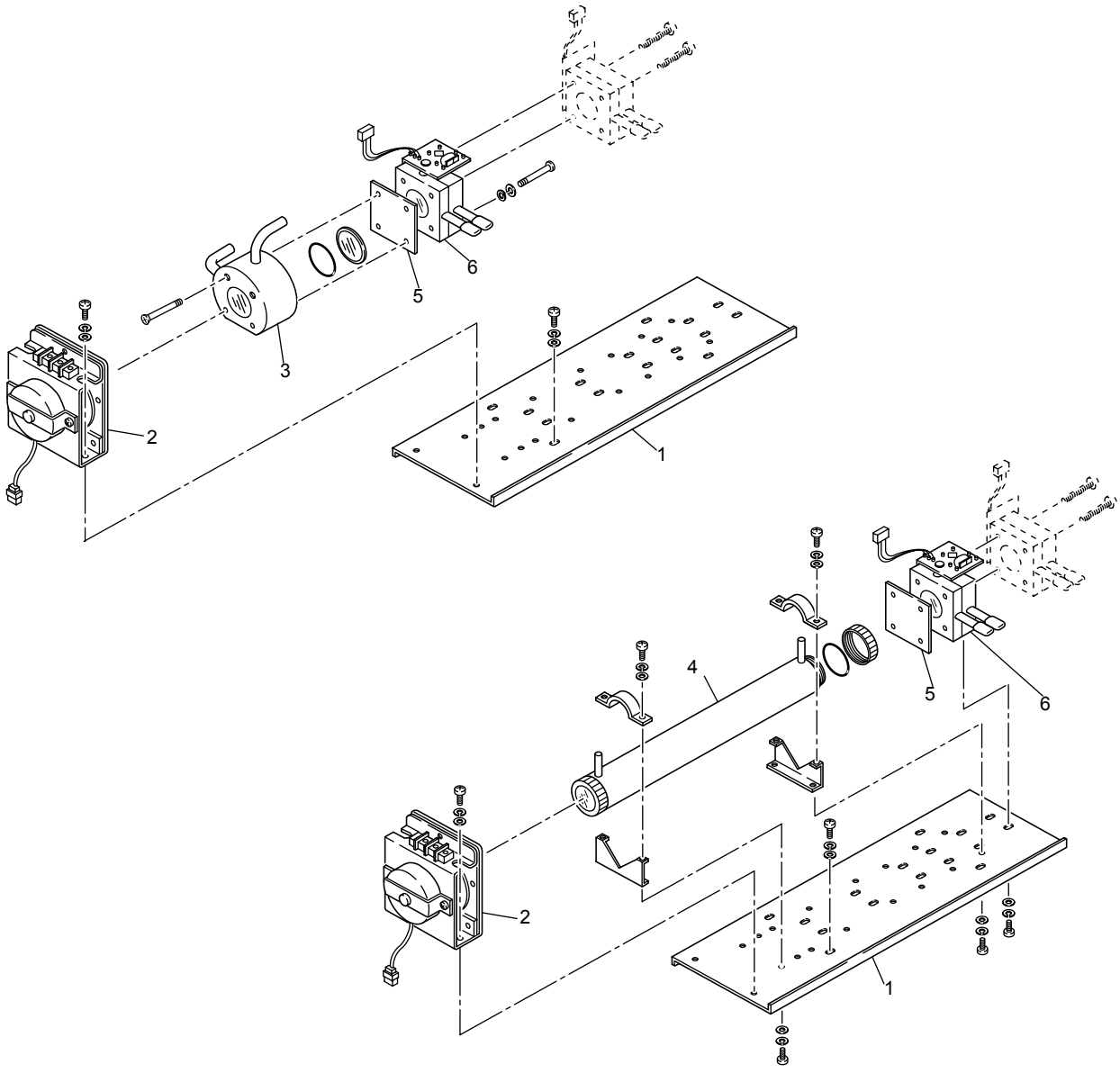

No.	Parts order No.	Parts name	Recommended replacement cycle	Note
1	ZZPZSV1-E040	Optical system baseboard	—	
2	ZZPZSV1-E050	Light source unit	About 7 years <sup>Note 3</sup>	Motor/chopper included See Page 15 for replacement procedure.
3	ZZPZSV1-E070	Block cell	— O-ring: About 2 years	Window/O-ring included See Page 17 for replacement procedure.
4	ZZPZSV1-E270	Pipe cell	— O-ring: About 2 years	Window/O-ring included See Page 17 for replacement procedure.
5	ZZPZSV1-E280	Gas filter	About 7 years <sup>Note 3</sup>	See Page 20 for replacement procedure.
6	ZZPZSV1-E200	Detector	About 7 years <sup>Note 3</sup>	Order No. varies depending on range/component. See Page 18 for replacement procedure.

Note 1: Specify “Parts order No.” on the list when ordering the parts.

Note 2: The replacement cycle varies depending on use conditions.

Note 3: Gas is sealed in the light source unit/gas filter/detector.

Be sure to replace them following the recommended replacement cycle irrespective of the use frequency.

7	Oxygen sensor	Galvanic	About 2 years	See Instruction Manual for replacement procedure.
		Magnetic	About 7 years	See Page 21 for replacement procedure.

# 1.3 Sampling unit

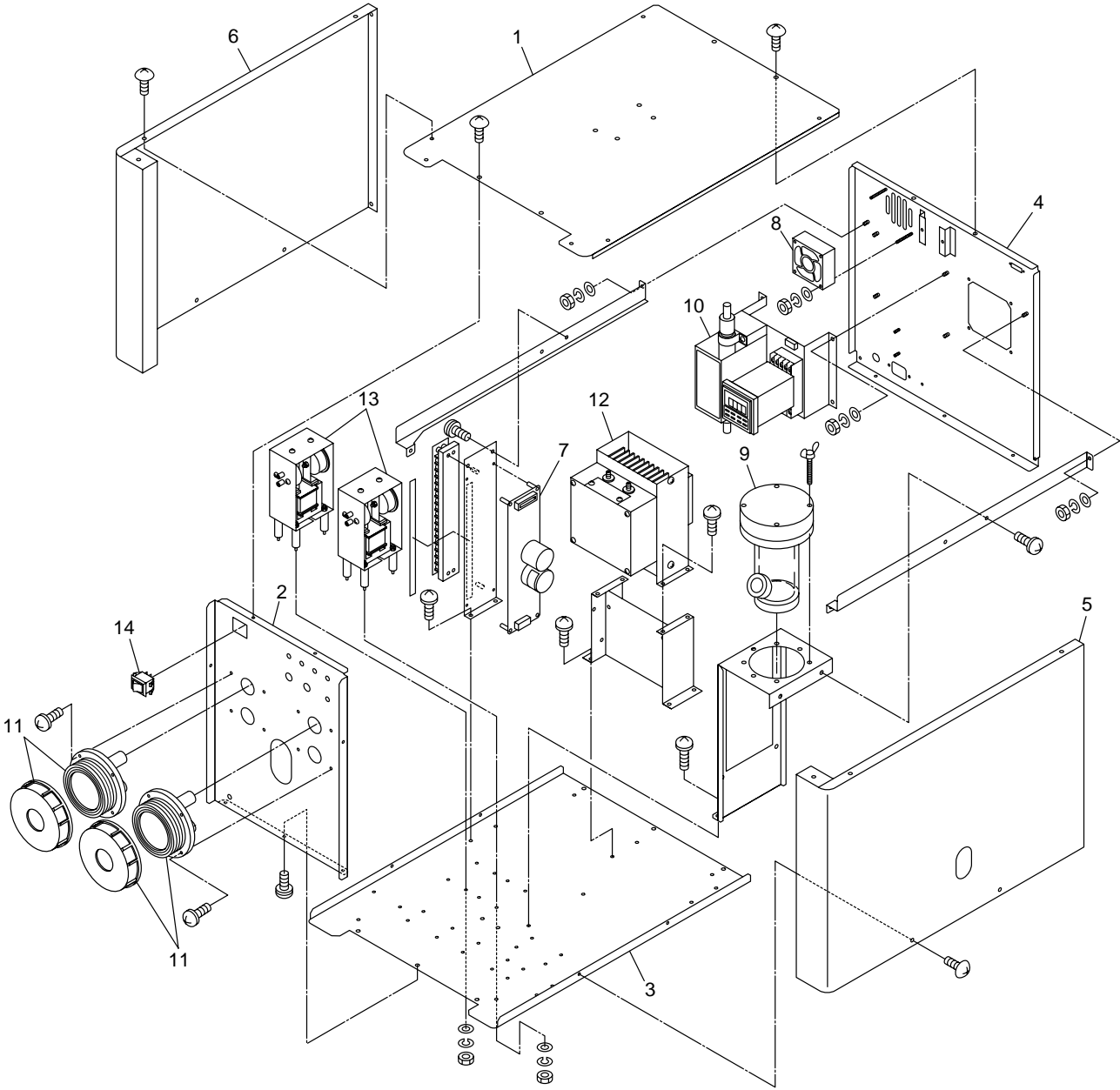

No.	Parts order No.	Parts name	Recommended replacement cycle	Note
1	ZZPZSV1-C040	Top board assembly	—	Handle not included
2	ZZPZSV1-C020	Front panel	—	Parts not included
3	ZZPZSV1-C010	Base	—	Parts not included
4	ZZPZSV1-C030	Rear board assembly	—	Parts not included
5	ZZPZSV1-C050	Side board assembly (right)	—	Window plate not included
6	ZZPZSV1-C060	Side board assembly (left)	—	
7	ZZPZSV1-C250	Power supply	—	See Page 22 for replacement cycle.
8	ZZPZSV1-C260	Exhaust fan unit	About 3 years (continuous operation)	See Page 22 for replacement cycle.
9	ZZPZSV1-C280	Mist filter	Element: About 1 year	See Instruction Manual for replacement procedure.
10	ZZPZSV1-C310	NO <sub>2</sub> /NO converter	Catalyst: About 6 months	See Instruction Manual for replacement procedure.
11	ZZPZSV1-C320	Membrane filter	Filter paper: About 1 to 2 months	See Instruction Manual for replacement procedure.
12	ZZPZSV1-C360	Electronic dehumidifier	Cooling fan: About 2 years	See Page 23 for replacement procedure.
13	ZZPZSV1-C370	Pump	Diaphragm: About 1 year	See Instruction Manual for replacement procedure.
14	ZZPZSV1-C200	Power switch	Contact: 5000 times (ON/OFF) Lamp: About 2 years (continuous operation)	See Page 14 for replacement procedure (analyzer unit, power switch)

Note 1: Specify “Parts order No.” on the list when ordering the parts.

Note 2: The replacement cycle varies depending on use conditions.

## 2. MAINTENANCE, INSPECTION, AND ADJUSTMENT AFTER REPAIR AND REPLACEMENT

### 2.1 Analyzer unit

#### 2.1.1 Display unit

Recommended period of replacement: 5 years

Error mode : End of service life of backlight, Deterioration of LCD

Phenomena : Image is not displayed. Image is not clear or blinks.

Check : (1) Press any key and check that the backlight comes on.  
(2) Set <Parameter mode> and <Display OFF time setting> to OFF.  
(3) Check the connection of the power supply connector of the backlight (main printed circuit board CN6).  
Also check the power supply voltage. (See “2.1.6 Main printed circuit board” of this manual.)  
(4) Check the connection of the connector of the LCD unit (Main printed circuit board CN2).

Measures : (1) Remove and then insert the connector to restore the performance of the contactor.  
(2) Replace the display unit.

Replacement : Remove the cable connected to the main printed circuit board off the connectors (CN6 and CN2).  
Remove the fastening screw (4-M4 screw) and replace the display unit with a new one.

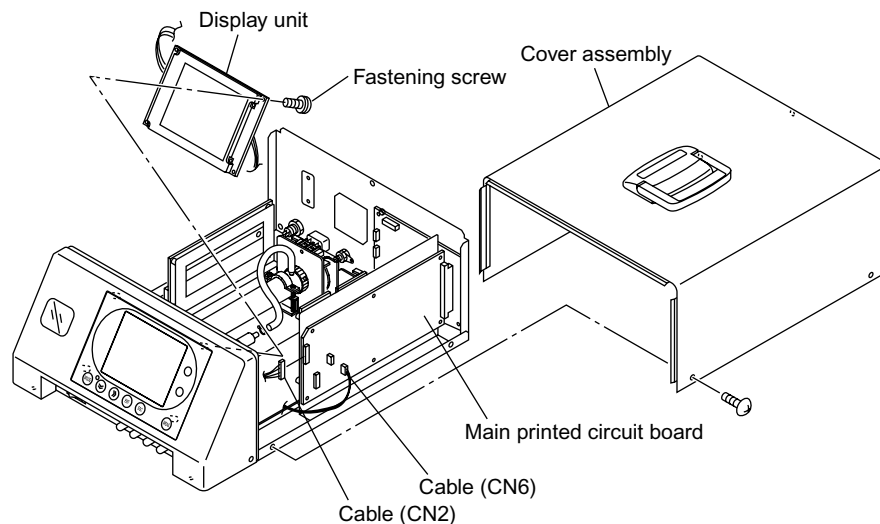

#### Caution on replacement

- (1) Be sure to turn off the power before removing and inserting the connector to avoid damage to the display drive IC, etc.

## 2.1.2 Membrane switch

Recommended period of replacement: 500,000 operations/contact

Error mode : Wear of key contact

Phenomena : Key operation cannot be performed.

Check : Check that the cable of the membrane switch is securely connected to the connector (main printed circuit board CN4).

Measures : (1) Remove and then insert the connector to restore the performance of the contactor.  
(2) Replace the membrane switch.

Replacement : Remove the cable connected to the main printed circuit board off the connector (CN4). The membrane switch is fastened to the front panel with two-sided tape. Peel off the sheet and attach a new membrane switch.

Caution on replacement
(1) Be sure to turn off the power before removing the connector to avoid damage to the IC, etc.
(2) Wipe the adhesive paste off the surface completely before attaching a new switch to avoid peeling due to dust.
(3) Connect the cable through the square hole on the front panel.
(4) The connector of the main printed circuit board (CN4) is provided with a stopper. Slide the both sides of the switch slightly toward you. Do not pull it forcibly to avoid damage. Insert the cable securely and fasten it with the stopper to mount the switch.

## 2.1.3 Power supply

Recommended period of replacement: None

Error mode : Specified power supply voltage is not output.

Phenomena : Image is not displayed. Display is not clear. Analog output is not produced.

Check : (1) Check the power supply voltage. (See “2.1.6 Main printed circuit board” of this manual.)  
 (2) Check the connection of the power supply connector.  
 (3) Check that the fuse is not blown.

Measures : (1) Remove and then insert the connector to restore the performance of the contactor.  
 (2) Replace the power supply.

Replacement : Remove the cables connected to the power supply (CN1 and CN2).  
 Remove the fastening screw (4-M3 screw) and replace the power supply with a new one.

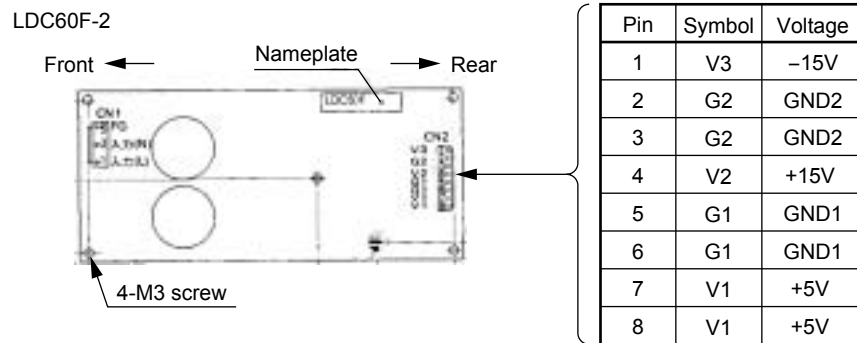

### Caution on replacement

- (1) Be sure to turn off the power before removing and inserting the connector to avoid damage to the parts.



## 2.1.4 Amplifier printed circuit board

(The amplifier printed circuit boards 1 and 2 are the same parts with different gains.)

Recommended period of replacement: None

Error mode : Failure of electronic parts

Phenomena : Indication failure

Check : (1) Check and adjust the voltage according to the description of the following table.

Item	Check terminal	Knob for adjustment	Regulation voltage
Power supply voltage	Between P15 and GND	—	+ 15.000 V DC $\pm$ 0.5 V DC
	Between N15 and GND	—	- 15.000 V DC $\pm$ 0.5 V DC
Detector voltage	Between DV1 and SG1	VR2	Voltage reading of the detector for the 1st or the 3rd component $\pm$ 0.1V
	Between DV2 and SG2	VR4	Voltage reading of the detector for the 2nd or the 4th component $\pm$ 0.1 V

(2) Adjust detector signals.

Feed zero gas and adjust the signals. If 2 printed circuit boards are provided, make adjustment for each one of them.

Item	Check terminal	Knob for adjustment	Regulation voltage
Detector signal	Between TP2 and SG1	VR1	+ 2.000 V DC $\pm$ 0.1 V DC
	Between TP6 and SG2	VR3	+ 2.000 V DC $\pm$ 0.1 V DC

Measures : (1) Remove and then insert the connector to restore the performance of the contactor.  
(2) Replace the amplifier printed circuit board.

Replacement : Remove the cables connected to the printed circuit boards (CN1, CN2, and CN3).  
Remove the fastening screw (4-M3 screw) and replace the amplifier printed circuit board with a new one.

Adjustment after replacement:

Insert connector CN3 only. (Do not insert CN1 or CN2.)

Insert the jumper pins (JP1 and JP2) into the same position as the old printed circuit board.

Turn on the power and check and adjust “power supply voltage” and “detector voltage.”

Turn off the power and insert connectors CN1 and CN2.

Turn on the power again, and adjust “detector signals.”

Perform zero and span calibrations to complete the work.

Caution on replacement
(1) Be sure to turn off the power before removing and inserting the connector to avoid damage to the detector.
(2) Be careful not to cause short circuit with other parts while checking and adjusting the voltage.
(3) One or two amplifier printed boards will be supplied depending on the number of components to be measured.
(4) Be sure to warm up the instrument fully before adjusting detector signals.

## 2.1.5 Control printed circuit board

Recommended period of replacement: None

Error mode : Failure of electronic parts

Phenomena : The sampling device is not operated. (End of service life of relay contact)  
 The pump is not operated. The brightness of the backlight cannot be adjusted.  
 Output is not produced. The chopping motor is not actuated.

- Check :
- (1) When output error is large or output is not produced
    - 1) Check that proper output type is selected.  
(See “Selecting output type” of the instruction manual.)
    - 2) Adjust the output and check that it is changed and that fine adjustment can be made.  
(See “Adjusting output” of the instruction manual.)
    - 3) Check that jumper pins are properly connected.  
(See “Selecting output” of the instruction manual.)
  - (2) When brightness cannot be adjusted or backlight does not come on
    - 1) Check that the display unit is operated properly.  
(See “2.1.1 Display unit” of this manual.)
    - 2) Check the brightness and voltage of the main printed circuit board.

Item	Check terminal	Regulation voltage
Brightness adjustment voltage value	Main printed circuit board Between TP9 and GND	29 V DC to 23 V DC (Can be adjusted evenly with the brightness adjusting key.)

- (3-1) When sample pump or drain pump is not operated (ZSVF)  
 Check the waveform of control output connector (CN13) with a self-synchronous device.

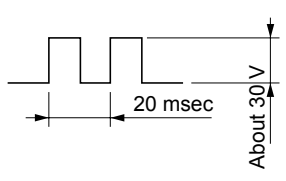
Item	Check terminal	Output waveform
Sample pump (Set the MEAS. key to ON and check in measurement mode.)	Control output connector Between 1 and 2	
Drain pump (Check in drain mode.)	Control output connector Between 3 and 4	

- (3-2) When sample pump is not operated (ZSVS)  
 Check the waveform of control output connector (CN13) with a self-synchronous device.

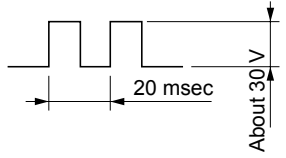
Item	Check terminal	Output waveform
Sample pump (Set the MEAS. key to ON and check in measurement mode.)	Control output connector Between 1 and 2	

(4) When solenoid valve is not operated (ZSVF)

Check the continuity of the control output connector (CN13) with an ohmmeter.

Item	Check terminal	Result
SV1, SV6 (Sample/zero switching)	Control output connector, Between 5 and 6	Contact ON/OFF
SV2 (Drain pot for MSF)	Control output connector, Between 7 and 8	Contact ON/OFF
SV3 (Drain pot for dehumidifier)	Control output connector, Between 9 and 10	Contact ON/OFF
SV4 (Pot for zero gas)	Control output connector, Between 11 and 12	Contact ON/OFF
SV5 (Span gas)	Control output connector, Between 13 and 14	Contact ON/OFF

Measures : (1) Remove and then insert the connector to restore the performance of the contactor.  
(2) Replace the control printed circuit board with a new one.

Replacement : Remove the cables connected to the printed circuit boards (CN1 to CN13).  
Remove the fastening screw (5-M3 screw), and replace the control printed circuit board with a new one.  
Insert the jumper pins (JP1 and JP2) into the same positions as the old printed circuit board.

Caution on replacement
1) Be sure to turn off the power before removing and inserting the connector to avoid damage to electronic parts.
2) Be careful not to cause short circuit with other parts while checking the voltage.

## 2.1.6 Main printed circuit board

Recommended period of replacement: None

Error mode : Failure of electronic parts

Phenomena : Control of each device malfunctions. Display error occurs.

Check : Check and adjust the power supply voltage.

Item	Check terminal	Knob for adjustment	Regulation voltage
Power supply voltage	Between P15 and VG	—	+ 15.000 V DC $\pm$ 0.5 V DC
	Between N15 and VG	—	- 15.000 V DC $\pm$ 0.5 V DC
	Between Vcc and GND	—	+ 5.000 V DC $\pm$ 0.5 V DC
	Between VD and VG	—	+ 5.000 V DC $\pm$ 0.5 V DC
	Between N12 and VG	—	- 12.000 V DC $\pm$ 0.5 V DC

Measures : (1) Remove and then insert the connector to restore the performance of the contactor.  
(2) Replace the main printed circuit board.

Replacement : Remove the cables connected to the printed circuit boards (CN2, CN3, CN4, and CN6).

Remove the fastening screw (6-M3 screw) and replace the main printed circuit board with a new one.

Data input and adjustment after replacement:

- (1) Enter all the setting data for <Menu mode>/<Parameter mode>/<Maintenance mode> manually. (See the instruction manual for details of each mode.)
- (2) Enter the data for <Factory mode> manually. (See <Description of factory mode> in Chapter 3 of this manual.)
- (3) Perform offset adjustment.
  - 1) Turn off the power and remove CN1 and CN2 of the amplifier printed circuit board (detector signal open).
  - 2) Turn on the power, and make <Factory mode> and <5. Zero offset> settings.
  - 3) Turn off the power again, and connect CN1 and CN2 on the amplifier printed circuit board.
- (4) Perform zero and span calibrations to complete the work.

Caution on replacement
<ol style="list-style-type: none"> <li>1) Be sure to turn off the power before removing and inserting the connector to prevent damage to electronic parts.</li> <li>2) Be careful not to cause short circuit with other parts while checking the voltage.</li> <li>3) We recommend you to order a main printed circuit board with data already entered. Specify "Date of manufacture," "Serial No." and "Type" when placing your order.</li> </ol>

## 2.1.7 Power switch

Recommended period of replacement:

Contact; 10,000 times (ON/OFF), Lamp; About 2 years

Error mode : Contact deterioration. End of service life of lamp

Phenomena : The power is not turned on. (The display does not come on.)  
The power can be turned on but the lamp does not come on.

Check : Check the fuse for blowing.

Measures : Replace the power switch.

Replacement : Remove the power switch, while pressing the projection for fastening from within the front panel. Remove the four cables from the tab terminal.

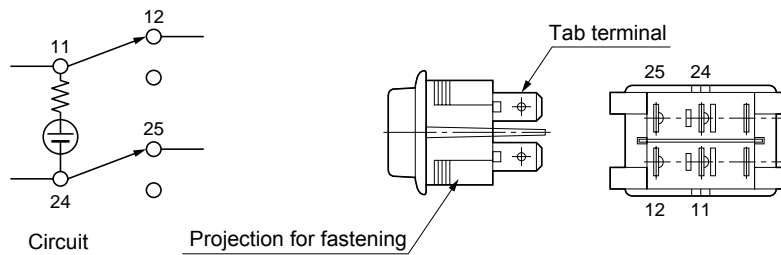

### Caution on replacement

- (1) Be sure to remove the power cable before inserting/removing the connector to avoid electric shock.
- (2) Be sure to connect wiring securely, referring to the wiring diagram.

---

## 2.2 Measuring unit

---

### 2.2.1 Light source unit

Recommended period of replacement: Seven years

Error mode : (1) Motor rotation stop  
(2) Short circuit and disconnection of the light source electrically heated wire.  
(3) Sealed gas leakage in light source

Phenomena : Unstable reading, scale out, and occurrence of Error-1

Check : (1) Motor:  
• Turn on the power and visually check that the shaft rotates.  
(Remove the light source unit, and you can check the rotation of the chopper through the window.)  
• Check that abnormal sound is not emitted.  
(2) Light source unit  
• Remove the power supply cable of the light source unit, and check that the resistance value falls within the  $37\Omega \pm 2\Omega$  range.  
There is a break if the reading appears infinite.  
With the decrease of the resistance value, the reading drifts in the minus direction.  
(3) If the reading becomes unstable because of the gas in the atmosphere, sealed gas may be leaking.

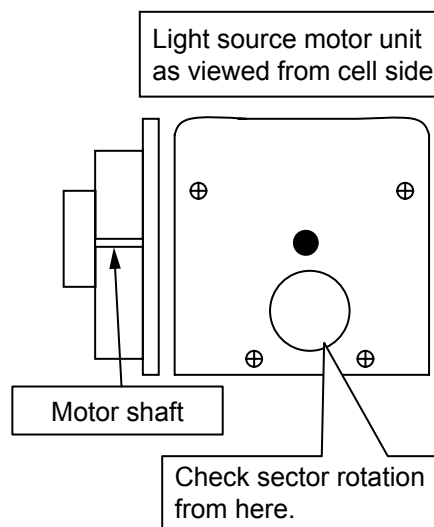

1) Checking chopper rotation

<Motor unit for light source>

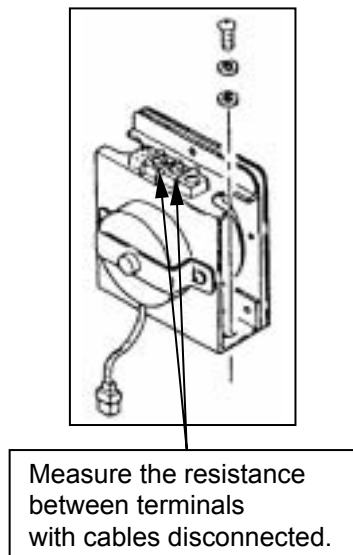

2) Measuring resistance value of light source

Measures : Replace the light source unit.

Replacement : Remove the screw fastening the unit to the optical system baseboard (2-M4), and replace the unit with a new one.

Adjustment after replacement:

Adjust the signals from the detector on the amplifier printed circuit board.

- (1) Feed zero gas.

Adjust the replaced optical system (amplifier printed circuit board) only.

Item	Check terminal	Knob for adjustment	Regulation voltage
Detector signal	Between TP2 and SG1	VR1	+ 2.000 V DC $\pm$ 0.1 V DC
	Between TP6 and SG2	VR3	+ 2.000 V DC $\pm$ 0.1 V DC

- (2) Perform zero and span calibrations to complete the work.

Caution on adjustment
▪ Be sure to warm up the instrument fully before adjusting detector signals.

## 2.2.2 Cell, cell window and O-ring (common to block cell and pipe cell)

Service life : Usable unless contaminated or corroded.

Recommended period of replacement: 2 years with O-ring

(1) Error mode : Contamination of cell, mixture of foreign matter, and contamination of cell window

Phenomena : Scale-out indication, drift and calibration error occurred to gas analyzer

Check : Disassemble the cell to assure that the inside is clean.

(2) Error mode : Crack in cell window

Phenomena : No change in indication, slow response, calibration error, and indication fluctuation

Check : Visually check the cell window for damage.

Measures : Cell Clean the inside of the cell (refer to the instruction manual for details). Replace if the inside is exposed to excessive contamination or corrosion.

Cell window Clean the cell window. Replace if the inside is exposed to excessive contamination.

Replacement : See the instruction manual.

Adjustment after clean and replacement:

Adjust detector signals.

(1) Feed zero gas and make an adjustment.

Item	Check terminal	Knob for adjustment	Regulation voltage
Detector signal	Between TP2 and SG1	VR1	+2.000 V DC $\pm$ 0.1 V DC
	Between TP6 and SG2	VR3	+2.000 V DC $\pm$ 0.1 V DC

(2) Perform zero and span calibrations to complete the work.

Caution on adjustment
<ul style="list-style-type: none"> <li>Be sure to warm up the instrument fully before adjusting detector signals.</li> </ul>



## 2.2.3 Detector (other than O<sub>2</sub> sensor)

Recommended period of replacement: 7 years

(1) Error mode : Damage to mass-flow detector

Phenomena : Scale-out indication of the gas analyzer

Check : Turn OFF the power of the gas analyzer and disconnect the connector connected from the detector to amplifier printed circuit board. (Amplifier printed circuit board CN1, CN2). Measure resistance between 4 – 7 and 5 – 7 of the bridge printed circuit board on the detector. The measure values must be between 25Ω and 60Ω. If the resistance value is fluctuated beyond the specified range, the detector element may be damaged.

Note: Do not use measurement instrument that allows a current of 2 mA or more to be supplied when measuring resistance, otherwise the element can be damaged.

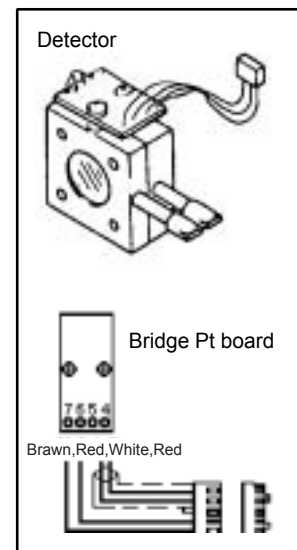

(2) Error mode : Sensitivity deterioration due to sealed gas leak

Phenomena : Calibration error and fluctuation in indication

Check : Check indication value at zero point

..... Check the indication value for each component on the <Sensor Input Value> screen in the <Maintenance mode>.

If the light source is in normal condition and the cell is free of contamination, the counter value indicates 38000 to 42000 when zero gas is supplied. If the counter value is below the range, sensitivity can be degraded.

Measures : Replace detector.

Replacement : (1) Block cell

Remove the light source unit.

The detector is fastened together with the light source unit and the block cell.

Remove the screw at the bottom of the detector (2-M4), and the light source unit can be separated. Then remove the screw at the top of the block cell (2-M4) and remove the detector.

(2) Pipe cell

Remove the optical system baseboard from the main unit.

The detector is fastened with a screw (2-M4) at the back of the optical system baseboard.

Adjustment after replacement:

Adjust the amplifier printed circuit board.

(1) Adjusting the power supply voltage of the detector:

Insert connector CN3 only. (Do not insert CN1 and CN2.)

Turn on the power and adjust the “detector voltage” shown below.

Item	Check terminal	Knob for adjustment	Regulation voltage
Detector voltage	Between DV1 and SG1	VR2	Voltage reading of the detector for the 1st or the 3rd component $\pm 0.1$ V
	Between DV2 and SG2	VR4	Voltage reading of the detector for the 2nd or the 4th component $\pm 0.1$ V

(2) Adjusting detector signals:

Feed zero gas.

Turn off the power and insert connectors CN1 and CN2.

Turn on the power again, and adjust the “detector signals.”

Adjust the replaced optical system (amplifier printed circuit board) only.

Item	Check terminal	Knob for adjustment	Regulation voltage
Detector signal	Between TP2 and SG1	VR1	+2.000 V DC $\pm 0.1$ V DC
	Between TP6 and SG2	VR3	+2.000 V DC $\pm 0.1$ V DC

(3) Perform zero and span calibrations to complete the work.

Note: Adjust the detector voltage on the printed circuit board and plug the connector into the detector. Do not insert the connector before voltage regulation, or the element may be damaged.

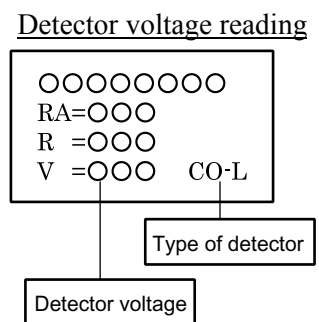

**Caution on adjustment**

- Be sure to warm up the instrument fully before adjusting detector signals.

## 2.2.4 Gas filter

Recommended period of replacement: 7 years

Error mode : Sealed gas leak

Phenomena : Increase of interference of other gases, linear deficiency, and drifting of reading in minus direction

Check : Perform zero/span calibration, feed the gas at the rate around the center of the range, and check the linearity.

Measures : Replace the gas filter.

Replacement : Replace by referring to “2.2.3 Detector (other than O<sub>2</sub> sensor)” of this manual.

Adjustment after replacement:

Adjust the detector signals of the amplifier printed circuit board.

(1) Feed zero gas.

Turn on the power and adjust “detector signals.”

Item	Check terminal	Knob for adjustment	Regulation voltage
Detector signal	Between TP2 and SG1	VR1	+2.000 V DC ± 0.1 V DC
	Between TP6 and SG2	VR3	+2.000 V DC ± 0.1 V DC

(2) Perform zero and span calibrations to complete the work.

### Caution on adjustment

- Be sure to warm up the instrument fully before adjusting detector signals.

## 2.2.5 Oxygen sensor

### (1) Galvanic oxygen sensor

Recommended period of replacement: 2 years

Error mode : Deterioration of the sensor

Phenomena : Span drift or unstable reading due to deterioration of sensitivity

Check : Remove the connector (CN9) inserted into the printed circuit board for control.  
Connect a digital voltmeter to both sides of the connector on the oxygen sensor side.  
If the voltage is 10mV or lower in atmospheric suction state, replace the sensor.

Measures : Replace the galvanic oxygen sensor.

Replacement : See the instruction manual.

Adjustment after replacement:

Perform zero/span calibration of the oxygen sensor to complete the work.

### (2) Magnetic sensor

Recommended period of replacement: 7 years

Error mode : Deterioration of the sensor

Phenomena : Drift or unstable reading due to deterioration of sensitivity

Check : Check the voltage between check terminals TP4 and SC on the main printed circuit board.

Main printed circuit board check terminal	Voltage when zero gas is fed	Voltage when span gas (21%O <sub>2</sub> ) is fed
Between TP4 and SC	0.000 V ±0.1 V	Normal range: 0.500 V or higher

Measures : Replace the magnetic oxygen sensor.

Replacement : Remove the flat connector inserted into the oxygen sensor.  
Remove the screw on the oxygen sensor mounting stage (2-M4).  
Replace the oxygen sensor with a new one.

Adjustment after replacement:

Perform zero/span calibration of the oxygen sensor to complete the work.

## 2.3 Sampling unit

### 2.3.1 Power supply

Recommended period of replacement: None

Error mode : Specified power supply voltage is not output.

Phenomena : Solenoid valve, fan, or thermoregulator does not operate.

Check : (1) Check the power supply voltage.

Remove the connector (CN2) of the power supply, and check that the voltage between 8 and 1 (GND) falls within the 12.000 V DC  $\pm$  0.5 V DC range.

: (2) Check the connection of the power supply connector.

: (3) Check that the fuse is not blown.

Measures : (1) Remove and then insert the connector to restore the performance of the contactor.

(2) Replace the power supply.

Replacement : Remove the cables connected to the power supply (CN1 and CN2).

Remove the fastening screw (4-M3 screw) and replace the power supply with a new one.

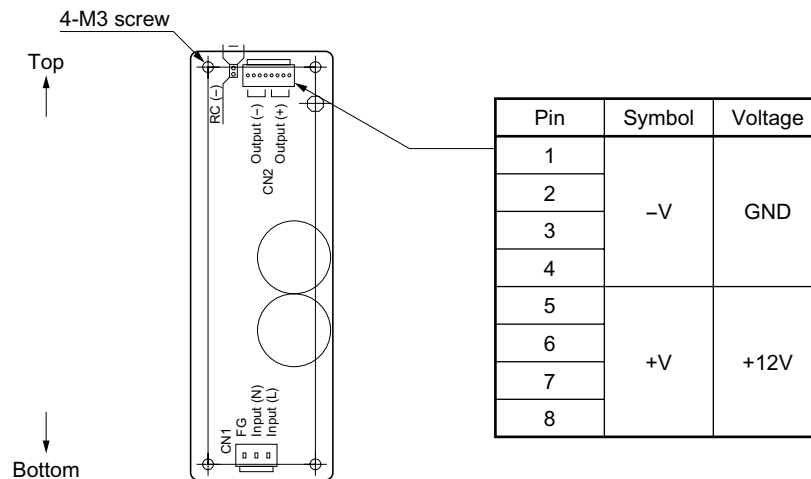

### 2.3.2 Exhaust fan unit

Recommended period of replacement: 3 years

Error mode : End of service life of the fan

Phenomena : The fan does not operate.

Check : Check the power supply voltage.

Check that voltage of 12.000 V DC  $\pm$  0.5V DC is supplied between relay terminals 13 and 16 (GND).

Measures : Replace the fan with a new one.

Replacement : Remove the wiring connected between relay terminals 13 and 16 (GND).

Remove the nut fastening the fan unit at the rear face assembly (4-M4) and then remove the unit.

### 2.3.3 Electric dehumidifier

Recommended period of replacement: Cooling fan 2 years

Error mode : End of service life of the fan

Phenomena : The fan does not operate.

Check : (1) Check that the reading of the thermoregulator mounted at the backboard falls within the range from 1°C to 5°C.

(2) Check that the fan is rotating.

Measures : Replace the electronic dehumidifier.

Replacement : (1) Remove the piping.

1) Remove the gas inlet/outlet piping at the top (2 pipes).

2) Remove the drain outlet pipe at the bottom.

We recommend you to remove the piping from the bottom of the drain pot and then separate it from the pot.

(2) Remove the wiring.

1) Remove the fan wiring from the relay connector.

2) Remove the thermocouple connected between 1 and 2 of the thermoregulator.

3) The power supply is connected to SSR terminal No.8 and the relay connector.

(3) The main unit is mounted to the baseboard assembly with a fastening screw (4-M4).

Remove the screw, and replace the electronic dehumidifier with a new one.

Caution on replacement
(1) Be sure to use a hose band for piping connection at the time of assembly. Otherwise insufficient airtightness may result.
(2) Be sure to discharge the drain before replacing the dehumidifier. Wipe off the moisture on the drain to avoid short circuit.
(3) Replace the electronic dehumidifier together with the thermoregulator.

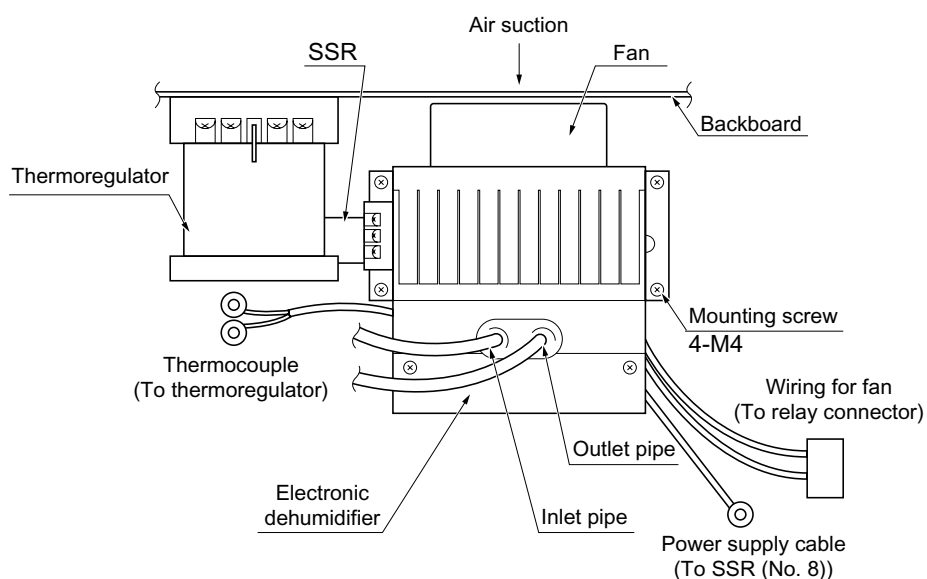



# 3. FACTORY MODE

## 3.1 How to go to Factory Mode

### Caution

Factory adjustment is made in this mode.

Be careful not to enter wrong settings to avoid malfunction of the analyzer.

Point the cursor to “14. To Factory” by using the  or  key on the Maintenance Mode screen and enter the  key. Then, the password input screen appears.

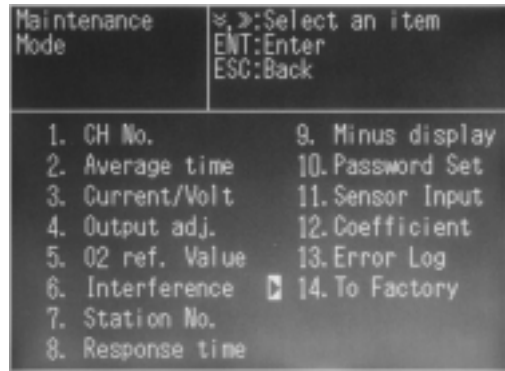

Enter the password, “2404.”

Select a digit using the  key.

Change the value using the  key.

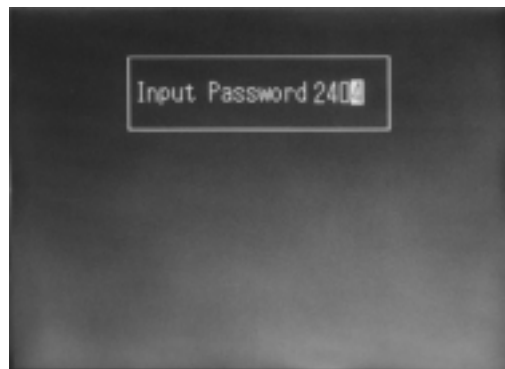

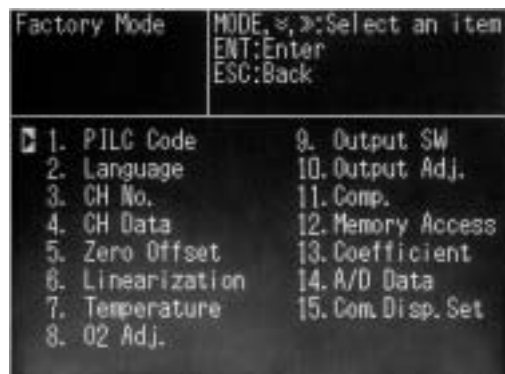

After password entry has been completed, press the  key, and the Factory Mode initial screen appears.

The cursor is placed at “1. PILC Code” as default.



## 3.2 How to go to each item in Factory Mode

On the factory mode screen that appears, move the cursor to the item to be set using the , , or  key.

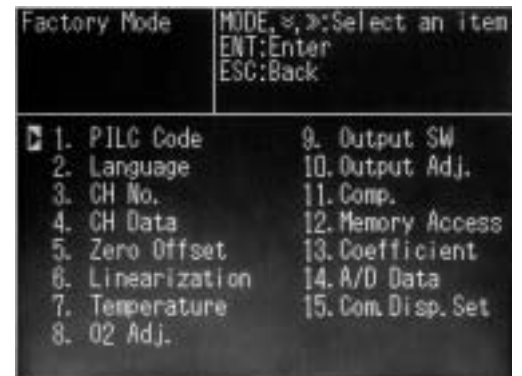

To get access to each setting screen, press the  key.

To return from each setting screen to the initial screen, press the  key.

Into each parameter screen

When escaping from the Factory Mode screen to the Maintenance Mode screen, press the  key.





## 3.3 Setting item in Factory Mode

### 3.3.1 PILC code

**Function:** Set PILC code and device No.

The settings within each factory mode are not revised automatically.

**Operation:** The PILC code setting screen is shown at right.

Change the value using the  and  keys.

Select a digit using the  key.

Press the  key to confirm the setting.

Press the  key to return to the factory mode initial screen.

Note that the data is not stored unless the  key is pressed.

**Setting contents:** 0 to 9, A to Z

**Initial value:** [PILC: ZSV000010000000000000]  
[Serial No.: 00000000]

Note 1: Do not enter hyphen for PILC.

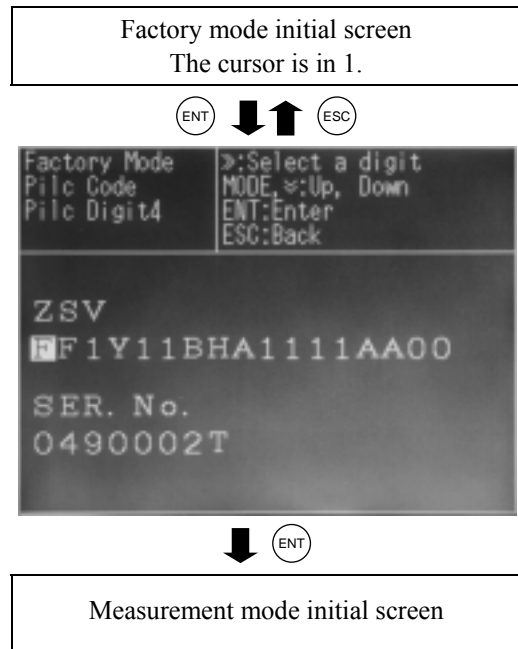



### 3.3.2 Language setting

**Function:** Switch the language for display between Japanese and English.

**Operation:** The language select screen is shown at right.

Press the  key to highlight the setting.

Select Japanese or English using the  and  keys.

Press the  key to confirm the setting.

Press the  to cancel the setting.

**Setting contents:** Japanese, English

**Initial value:** [English]

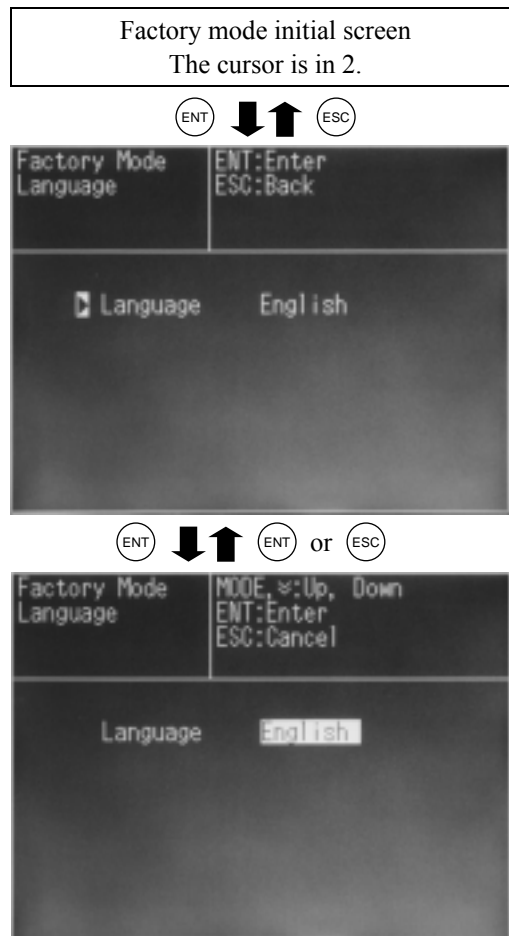

**Note:** The display is switched between Japanese and English as soon as the  key is pressed.





### 3.3.3 Number of channels (Measured component setting)

**Function:** Set the components for each channel to be displayed on the measurement screen. The setting determines the number of components to be measured.



**Operation:** The screen for setting the number of channels is shown at right.

Move the cursor to infrared ray component using the  and  keys.

Press the  key to enter the mode.

Move the cursor to optical system to be selected using the  and  keys.

Press the  key to highlight the name of components selected.

Select a component name using the  and  keys.

Press the  key to confirm the setting.

Press the  key to cancel the setting.



Optical system 1 is displayed on the left side, and optical system 2 on the right side viewed from the front of the instrument. Connector CN1 on the amplifier printed circuit board is for optical system X-1, and CN2 is for optical system X-2.

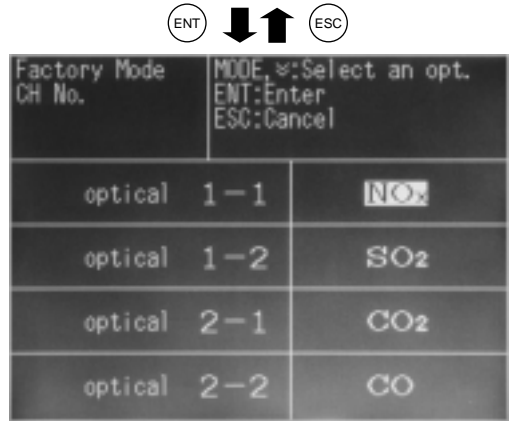
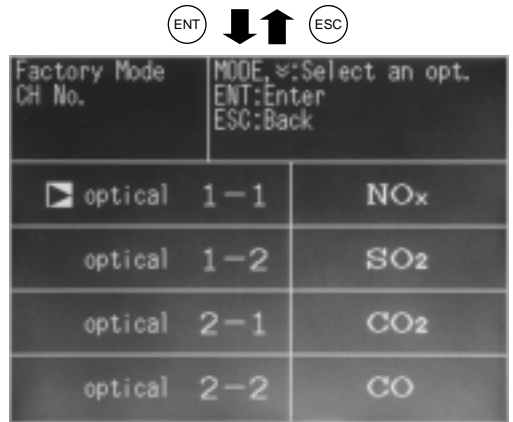
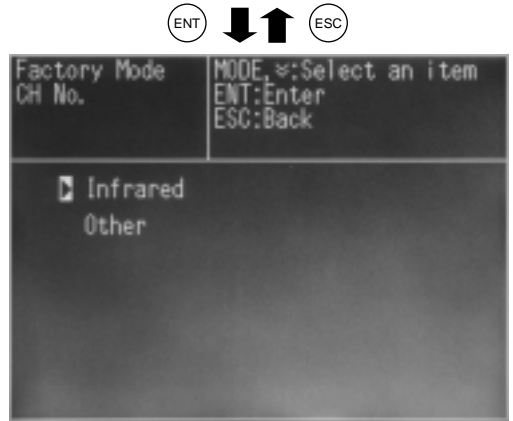

Note: Make the setting sequentially beginning from optical system 1-1. Be sure to select “None” for the optical systems without the sensor. Do not select “None” for all of them. Otherwise A/D conversion failure may result.





Factory mode initial screen  
The cursor is in 3.



Then select presence/absence of O<sub>2</sub> sensor and output type except for “infrared ray sensor.”

Select other channel allocations using the  and  keys.  
Press the  key to enter the mode.

Select the channel to be set using the  and  keys.  
Press the  key to highlight the name of component selected.

Select a component to be set using the  and  keys.  
Press the  key to confirm the setting.  
Press the  key to cancel the setting.

**Initial value:**

- ZSVF;** [CH1 = NO<sub>x</sub>, CH2 = SO<sub>2</sub>, CH3 = CO,  
CH4 = CO<sub>2</sub>, CH5 = O<sub>2</sub>, CH6 = Average corrected  
NO<sub>x</sub>, CH7 = Average corrected SO<sub>2</sub>,  
CH8 = Average corrected CO]
- ZSVS;** [CH1 = CH<sub>4</sub>, CH2 = CO<sub>2</sub>, CH3 = CO,  
CH4 = CP calculation

**Setting contents:**

- Instantaneous value:  
NO<sub>x</sub>, NO, SO<sub>2</sub>, CO, CO<sub>2</sub>, CH<sub>4</sub>, HC, C<sub>3</sub>H<sub>8</sub>, O<sub>2</sub>
- Instantaneous value after O<sub>2</sub> correction:  
NO<sub>x</sub> correction, SO<sub>2</sub> correction, CO correction
- Moving average after O<sub>2</sub> correction:  
Average after NO<sub>x</sub> correction, Average after SO<sub>2</sub>  
correction, Average after CO correction
- CP calculation value:  
CP calculation
- Others: None

Note: Channels and measured components are independent of each other.  
Make the setting so that the sensor input corresponds to the display.

Factory mode initial screen  
The cursor is in 3.

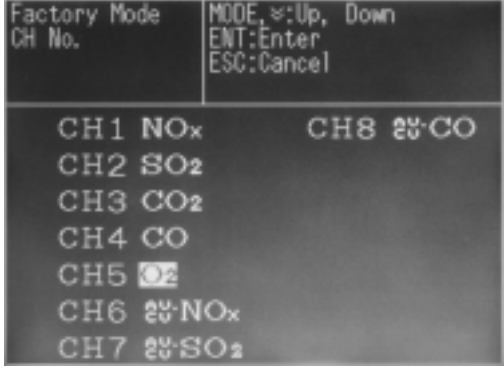
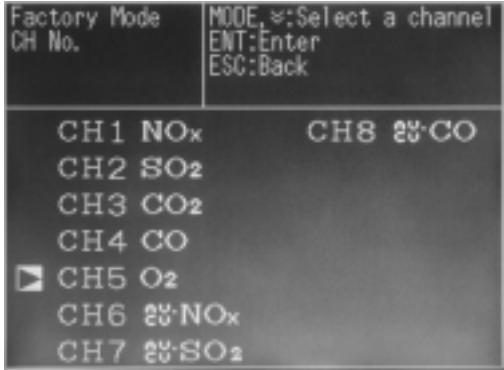
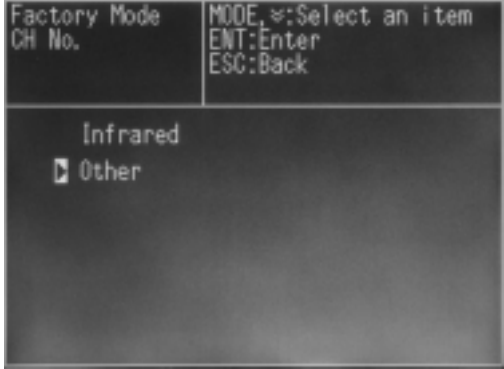

### 3.3.4 Channel parameter (setting of range and unit)

**Function:** Set the number of ranges, unit of concentration, decimal point position of the range, and the range value of each component.

**Operation:** The CH data setting screen is shown at right.

Select the channel to be set using the  $\odot$  and  $\text{MODE}$  keys.

Press the  $\text{ENT}$  key to enter the mode.

Select the item to be set using the  $\odot$  and  $\text{MODE}$  keys.

Press the  $\text{ENT}$  key to highlight the setting selected.

Select the setting using the  $\odot$  and  $\text{MODE}$  keys.

Move the digit using the  $\odot$  key and make the setting for each digit.

Press the  $\text{ENT}$  key to confirm the setting.

Press the  $\text{ESC}$  key to cancel the setting.

#### Setting contents:

Number of ranges:

Number of measurement ranges; 1, 2, 3 (3 max.)

Unit: Unit of measurement range; ppm or vol%, mg/m<sup>3</sup> or g/m<sup>3</sup> (Units ppm and vol% or mg/m<sup>3</sup> and g/m<sup>3</sup> cannot be selected at the same time. It is allowed that ppm is selected for range 1, while vol% is selected for range 2. Combination of ppm and mg/m<sup>3</sup> is not allowed.)

Decimal point position:

Decimal point position of measured concentration

Range setting: Range value setting

Setting up to the first decimal place (such as 0.5 vol%) is allowed.

Note 1: The full scale of the linearization table setting should be the maximum range of the setting range.

Setting example: In the case of the screen shown above, the full scale of range 1 is 500.0 ppm, and that of range 3 is 2000 ppm.

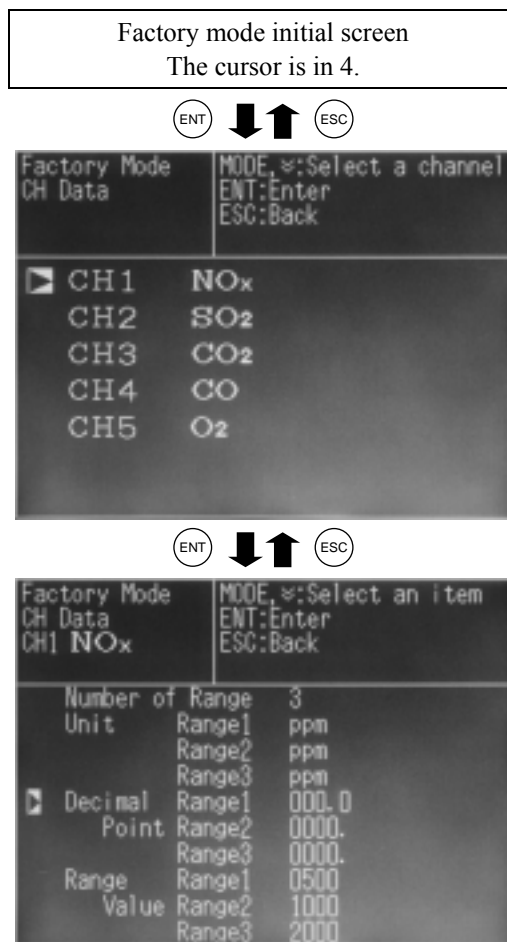

Note 2: The ratio of range of range 1 to range 3 is 1 to 5 at the maximum.





### 3.3.5 Zero offset

**Function:** Store the offset value of the A/D converter.

**Operation:** The zero offset screen is shown at right. Be sure to remove the input signal cable of the detector from the amplifier board before making the adjustment.

Select the channel using the  and  keys.

Press the  key to highlight the name of component selected.

Press the  key again, and offset adjustment is performed automatically and the value is selected.

Press the  key to cancel the adjustment.

Select ALL CH to perform adjustment for all the inputs.

**Setting contents:** Initial value [20000]

Note: Offset adjustment performed in this mode is for infrared ray component only. Perform O<sub>2</sub> offset adjustment of magnetic or galvanic O<sub>2</sub> meter in “3.3.8 O<sub>2</sub> adjustment” mode.

Factory mode initial screen  
The cursor is in 5.

   

Factory Mode Adjustment Zero Offset		MODE, ⌘:Select a channel ENT:Enter ESC:Back
CH	element	offset value
 CH 1	NO <sub>x</sub>	20076
CH 2	SO <sub>2</sub>	20076
CH 3	CO <sub>2</sub>	20118
CH 4	CO	20106
ALL CH	ALL	

Factory Mode Adjustment Zero Offset		ENT:Enter ESC:Cancel
CH	element	offset value
CH 1	<b>NO<sub>x</sub></b>	20076
CH 2	SO <sub>2</sub>	20076
CH 3	CO <sub>2</sub>	20118
CH 4	CO	20106
ALL CH	ALL	

Factory Mode Adjustment Zero Offset		MODE, ⌘:Select a channel ENT:Enter ESC:Back
CH	element	offset value
 CH 1	NO <sub>x</sub>	40390
CH 2	SO <sub>2</sub>	20076
CH 3	CO <sub>2</sub>	20118
CH 4	CO	20106
ALL CH	ALL	

### 3.3.6 Linearizer

**Function:** Set the linearize table calculated using the calibration curve measurement data.

This allows linearity correction to be made.

**Operation:** The linearize table setting screen is shown at right.

Select the CH to be set using the  $\odot$  and  $\text{MODE}$  keys.

Press the  $\text{ENT}$  key to enter the table setting screen.

Note: O<sub>2</sub> meter can also be set.

Note that O<sub>2</sub> meter setting is not required in ordinary cases because the sensor output signals of magnetic and galvanic O<sub>2</sub> meters are linear.

Select the set point using the  $\odot$ ,  $\odot$  and  $\text{MODE}$  keys.

Press the  $\text{ENT}$  key to highlight the setting.

Change the setting using the  $\odot$  and  $\text{MODE}$  keys.

Move the digit using the  $\odot$  key and make the setting for each digit.

Press the  $\text{ENT}$  key to confirm the setting.

Press the  $\text{ESC}$  key to cancel the setting.

**Setting contents:** The linearization function uses 16 broken line approximation for calculation. Enter the value of each break point calculated from the calibration curve for setting.

X and Y represent the X and Y axes, and points 1 to 16 correspond to each break point.

The first break point and the 16th break point correspond to the zero and values of the maximum range, "00000" and "20000" respectively.

**Initial value:** In the order of correction points from 1 to 16 both for X and Y axes [0, 800, 1600, 2400, 3200, 4000, 5000, 6000, 7000, 8000, 10000, 12000, 14000, 16000, 18000, 20000] (Non-linear state)

Factory mode initial screen  
The cursor is in 6.

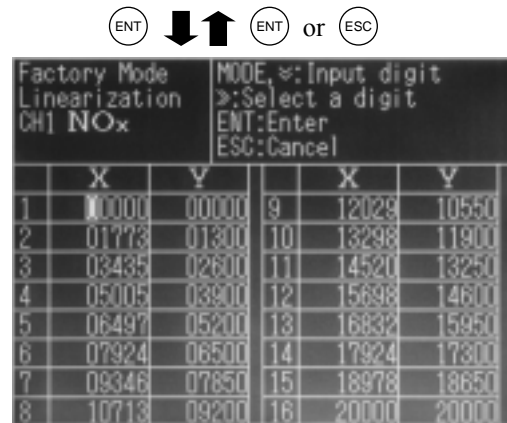
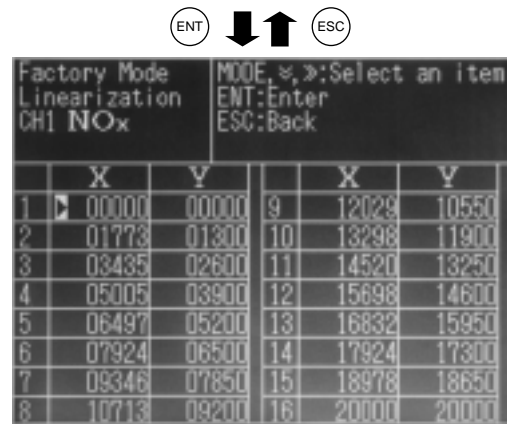
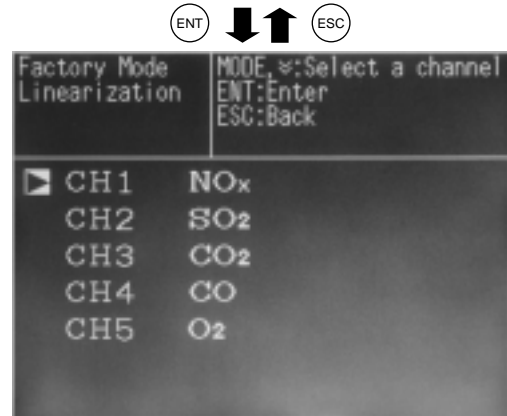



### 3.3.7 Temperature compensation

**Function:** Set the temperature compensation coefficient and temperature counts calculated from the temperature characteristic test data.

This allows temperature compensation to be performed.

**Operation:** The temperature compensation setting screen is shown at right.

Select the item to be set using the  and  keys.

Press the  key to enter the mode.

**Temperature table:**

Set the count of the temperature sensor for each temperature.



**Zero temperature compensation table:**

Set the temperature compensation coefficient at zero point for each temperature.



**Span temperature compensation table:**

Set the temperature compensation coefficient at span point for each temperature.

▪ **When temperature compensation table is selected**

Select the count using the , , and  keys.

Press the  key to highlight the setting.

Change the setting using the  and  keys.

Move the digit using the  key, and make the setting for each digit.

Press the  key to confirm the setting.

Press the  key to cancel the setting.

**Setting contents:**

The X-axis represents temperature (°C).

The Y-axis represents temperature count (A/D conversion value of the temperature sensor).

**Initial value:**

X-axis: In the order from 1 to 6 [-05, +05, +15, +25, +35, +45]

Y-axis: In the order from 1 to 6 [15940, 16750, 17560, 18370, 19145, 19920]

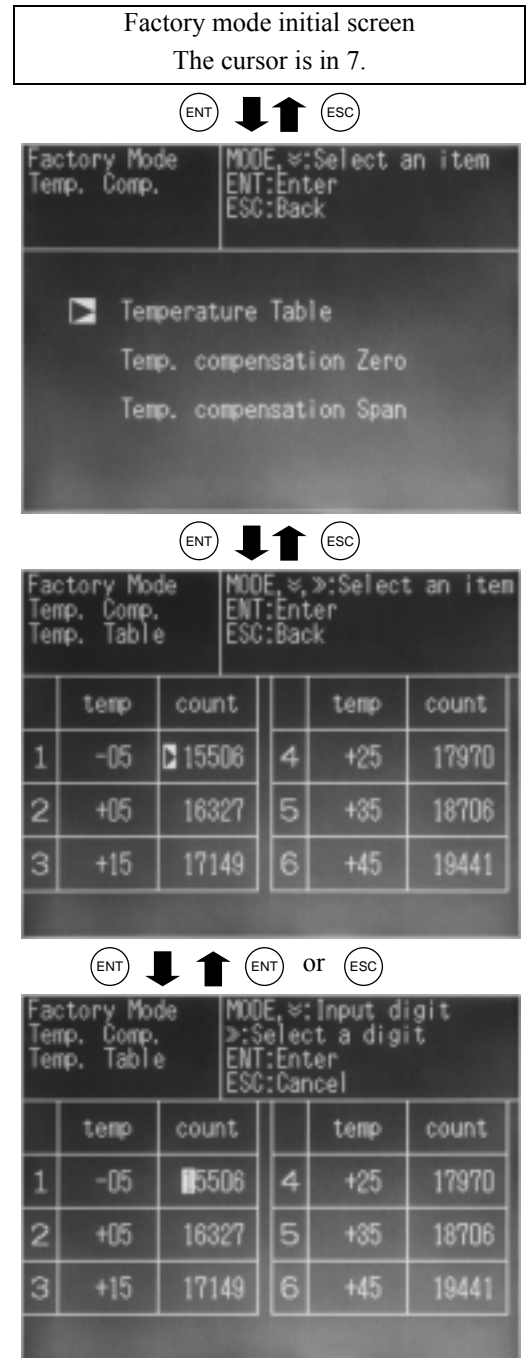



▪ **When zero temperature compensation table is selected**

Select a channel to be set using the and keys.

Press the key to enter the mode.

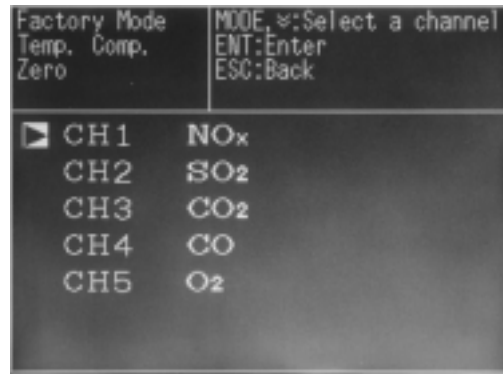

Select an item to be set using the , , and keys.

Press the key to highlight the setting.

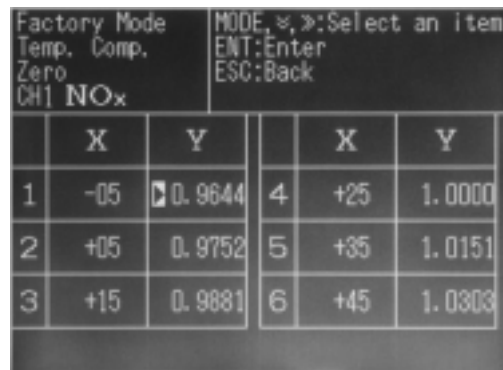

Change the setting using the and keys.

Move the digit using the key, and make the setting for each digit.

Press the key to confirm the setting.

Press the key to cancel the setting.

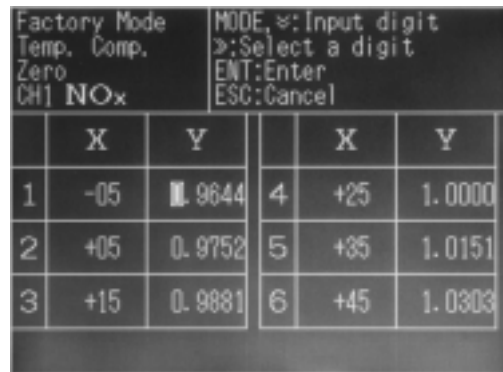

**Setting contents:**

Enter temperature (°C) for X-axis according to the temperature table (change not allowed).

Enter zero temperature compensation coefficient value for Y-axis.

**Initial value:** (The initial value of O2 meter differs only for Y-axis.)

X-axis: [-05, +05, +15, +25, +35, +45]

Y-axis: [1.0000] for all

Y-axis of O<sub>2</sub> meter: [+00000] for all

▪ **When span temperature compensation table is selected**

Select a channel to be set using the and keys.  
Press the key to enter the mode.

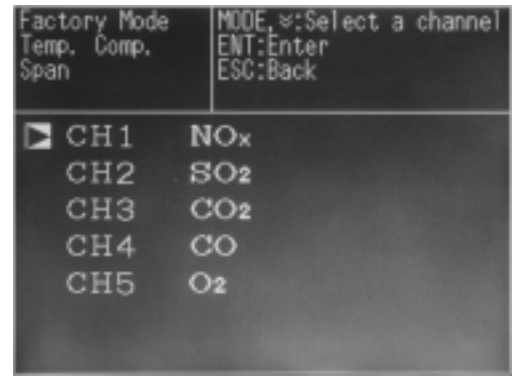

Select an item to be set using the , , and keys.  
Press the key to highlight the setting.

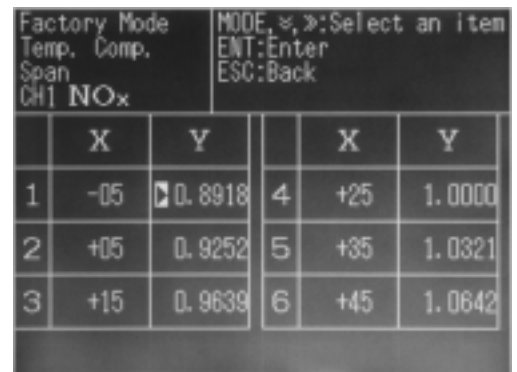

Change the setting using the and keys.  
Move the digit using the key, and make the setting for each digit.

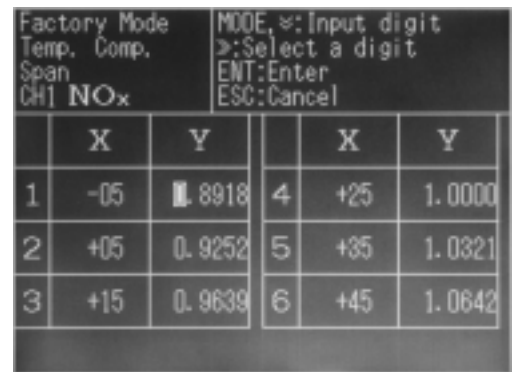

Press the key to confirm the setting.  
Press the to cancel the setting.

**Setting contents:**

Enter span temperature compensation coefficient.

**Initial value:** (The initial value of O<sub>2</sub> meter differs only for Y-axis.)

X-axis: [-05, +05, +15, +25, +35, +45]



Y-axis: [1.0000] for all

### 3.3.8 O<sub>2</sub> adjustment



**Function:** Select magnetic or galvanic system, and make required adjustments for each O<sub>2</sub> meter.

**Operation:** The O<sub>2</sub> adjustment setting screen is shown at right.

▪ O<sub>2</sub> meter selection

Select the item to be set using the  and  keys.

Press the  to enter the mode.

Select the setting contents using the  and  keys.

Press the  key to confirm the setting.

Press the  key to cancel the setting.

**Setting contents:**

Initial value: [Galvanic (Full cell)]

O<sub>2</sub> meter selection: Magnetic, Galvanic

Galvanic system only is used for ZSVS.

Note: Be sure to perform O<sub>2</sub> offset adjustment.

Factory mode initial screen  
The cursor is in 8.

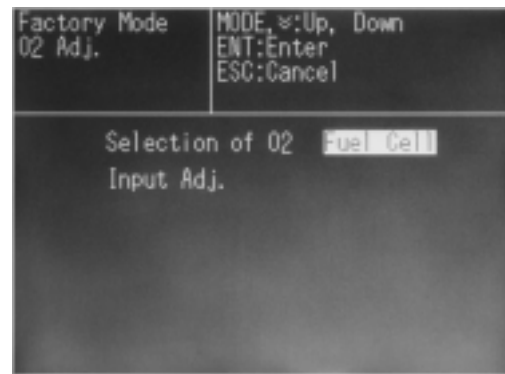
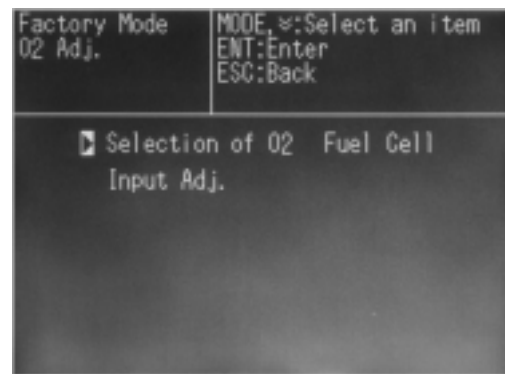
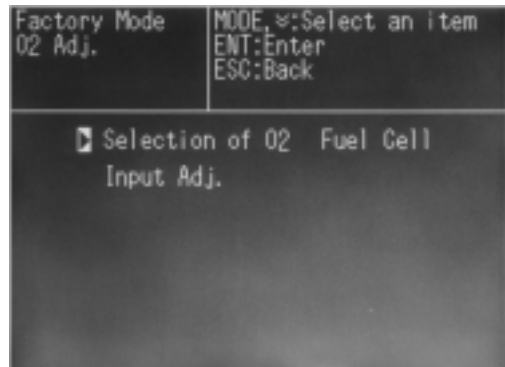



▪ O<sub>2</sub> offset adjustment

In O<sub>2</sub> offset adjustment, electric offset values required for the measurement with magnetic and galvanic O<sub>2</sub> meters are stored.

Operation: The O<sub>2</sub> offset adjustment screen is shown at right.

Remove JP10 (jumper pin) on the control printed circuit board and short-circuit the pin No.2 to the GND pin of the main printed circuit board before making the adjustment.

Select the item to be set using the  and  keys.

Press the  key to enter the mode.

Press the  key again, and “O<sub>2</sub> offset adjustment underway” appears in the comment field, and adjustment is completed automatically.

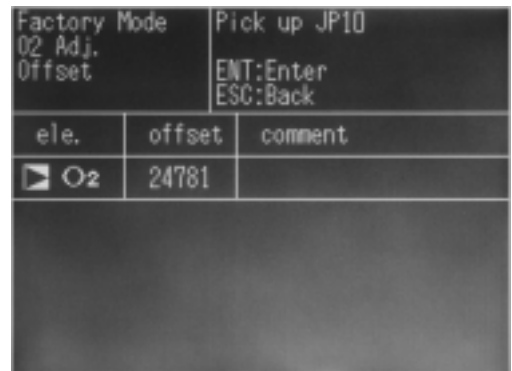
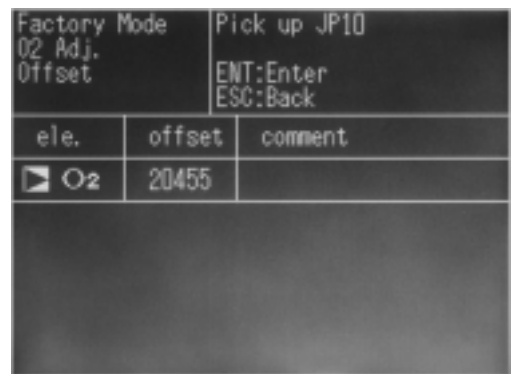
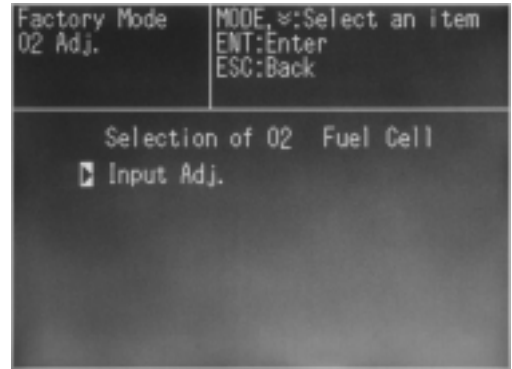



### 3.3.9 Output selection



**Function:** Select 4 to 20 mA DC or 0 to 1 V DC for analog output value.

Note: Select the output and then switch the output jumper pin on the control board.

**Operation:** The analog output selection screen is shown at right.

Select the output to be set (OUT 1 to 8) using the  and  keys.

Press the  key to highlight the setting.

Change the setting using the  and  keys.

Press the  key to confirm the setting.

Press the  key to cancel the setting.

**Setting contents:**

The outputs (OUT) 1 to 8 correspond to CH1 to CH8 respectively.

**Initial value:**

[4 to 20 mA] for all of OUT1 to OUT8

Factory mode initial screen  
The cursor is in 9.



Factory Mode		Change pin			
Output SW		MODE, ⌘: Select an item			
		ENT: Enter			
		ESC: Back			
OUT	OUTPUT	SHORT	OUT	OUTPUT	SHORT
1	4-20mA	JP1 1-2	7	4-20mA	JP7 1-2
2	4-20mA	JP2 1-2	8	4-20mA	JP8 1-2
3	4-20mA	JP3 1-2			
4	4-20mA	JP4 1-2			
5	4-20mA	JP5 1-2			
6	4-20mA	JP6 1-2			

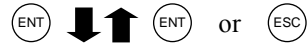



Factory Mode		Change pin			
Output SW		MODE, ⌘: Select output			
		ENT: Enter			
		ESC: Cancel			
OUT	OUTPUT	SHORT	OUT	OUTPUT	SHORT
1	4-20mA	JP1 1-2	7	4-20mA	JP7 1-2
2	4-20mA	JP2 1-2	8	4-20mA	JP8 1-2
3	4-20mA	JP3 1-2			
4	4-20mA	JP4 1-2			
5	4-20mA	JP5 1-2			
6	4-20mA	JP6 1-2			

### 3.3.10 Output adjustment



**Function:** Adjust the zero point and span point of the analog output to 4 to 20 mA or 0 to 1 V DC.

**Operation:** The Analog Output Adjustment screen is as shown in right.

Select the output to be adjusted (OUT 1 to 8) using the , , and  keys, and connect the digital voltmeter to the output terminal.

\* See “3.3.9 Output selection” for the correspondence between OUT No. and output.

Press the  key to highlight the setting.

Adjust the value using the  and  keys, seeing the value on the digital voltmeter.

Move the digit using the  key, and make an adjustment for each digit.

Adjust the output as follows:

Zero: 4 mA ± 0.05 mA DC or 0 V ± 0.005 V DC

Span: 20 mA ± 0.05 mA DC or 1 V ± 0.005 V DC

Press the  key to confirm the setting.

Press the  key to cancel the setting.

**Setting contents:**

The outputs (OUT) 1 to 8 correspond to CH1 to CH8 respectively.

The settings are digital values transmitted to the D/A converter.

**Initial value:** OUT1 to 8

Current output: [Zero = 0800]  
[Span = 3850]

Voltage output: [Zero = 0540]  
[Span = 3440]

Factory mode initial screen  
The cursor is in 10.



Factory Mode Output Adj.			MODE, >: Select output ENT: Enter ESC: Back		
OUT	ZERO	SPAN	OUT	ZERO	SPAN
1	0580	3470	7	0513	3397
2	0574	3458	8	0592	3471
3	0562	3447			
4	0565	3449			
5	0563	3444			
6	0540	3437			



Factory Mode Output Adj.			MODE, >: Adjust output >: Select a digit ENT: Enter ESC: Cancel		
OUT	ZERO	SPAN	OUT	ZERO	SPAN
1	0580	3470	7	0513	3397
2	0574	3458	8	0592	3471
3	0562	3447			
4	0565	3449			
5	0563	3444			
6	0540	3437			

### 3.3.11 Interference compensation

**Function:** Correct the interference of other gases.



The compensation includes the following:

- NO<sub>x</sub> to H<sub>2</sub>O
- SO<sub>2</sub> to H<sub>2</sub>O
- CO to CO<sub>2</sub>



Note: The compensation screen is not displayed unless target components are selected in section 3.3.3 “Number of channels (measurement component setting).”

**Operation:** The compensation setting screen is shown at right.

▪ **How to correct NO<sub>x</sub> and SO<sub>2</sub> to H<sub>2</sub>O**

Select the component to be corrected using the  and  keys.

Press the  key to enter the mode.

Make +/- setting and enter the concentration value using the  and  keys.

Move the digit using the  key, and make the setting for each digit.

Press the  to confirm the selection.

Press the  key to cancel the setting.

**Setting contents:**

- (1) Select +/- of the effect of interference.
- (2) Measure the value of effect of interference beforehand, and enter the concentration value reflecting the effect. (Enter the concentration value affected by the interference.)



**Initial value:** [+0000 count] both for NO<sub>x</sub> and SO<sub>2</sub>

Note: The compensation value is increased/decreased in this mode. Determine the compensation value in Maintenance mode <6. Moisture interference adjustment>.

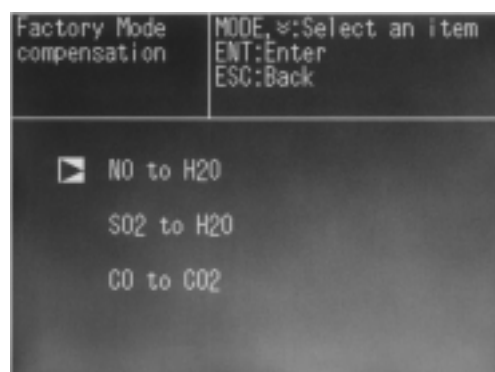
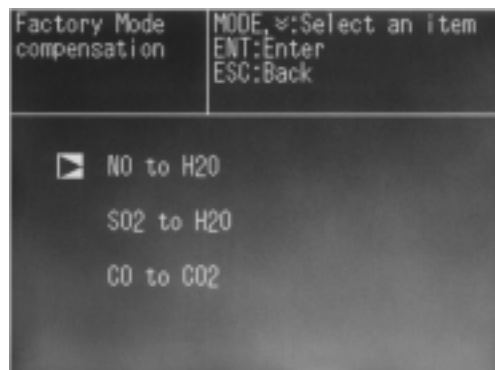
Factory mode initial screen  
The cursor is in 11.





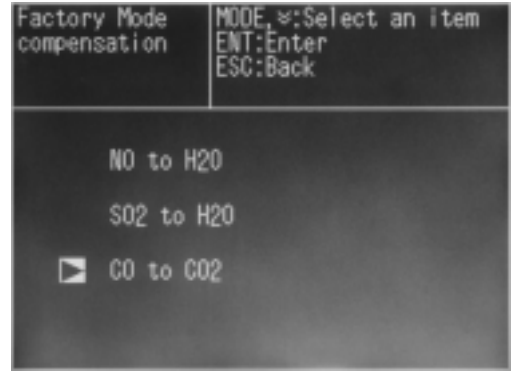

**• How to correct CO to CO<sub>2</sub>**

Select the component to be corrected using the  and  keys.



Press the  key to enter the mode.



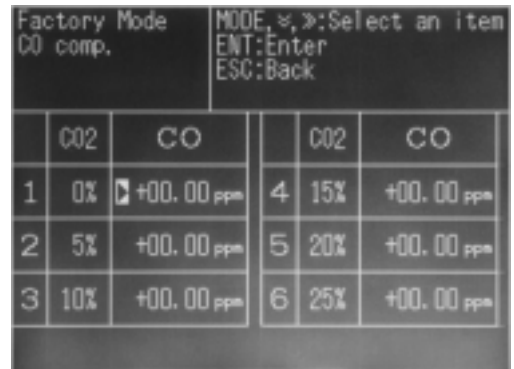

Select the correction point using the , , and  keys.

Press the  key to highlight the setting.



Make +/- setting and enter the concentration value using the  and  keys.

Move the digit using the  key, and make the setting for each digit.

Press the  to confirm the selection.

Press the  key to cancel the setting.

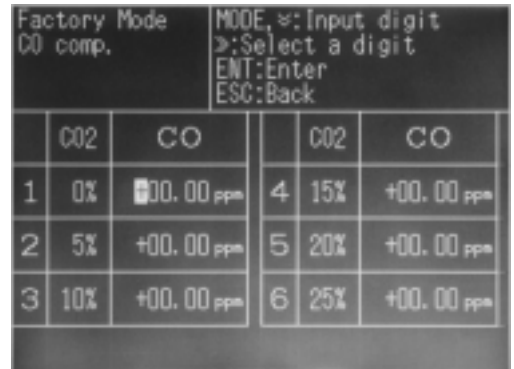

**Setting contents:**

- (1) Select +/- of the effect of interference.
- (2) Measure the value of effect of interference beforehand, and enter the concentration value reflecting the effect. (Enter the concentration value affected by the interference.)

**Initial value:**

CO<sub>2</sub>: [0% 5% 10% 15% 20% 25%]  
 CO: [+00.00 ppm]



### 3.3.12 Memory rewrite

**Function:** Directly read and write EEPROM and RAM data to the specified address.  
Perform soft reset.

Note: An address map is required to write values here. Do not perform memory rewrite, because malfunction results if improper value is written.

**Operation:** The set memory screen is shown at right.



Factory mode initial screen  
The cursor is in 12.

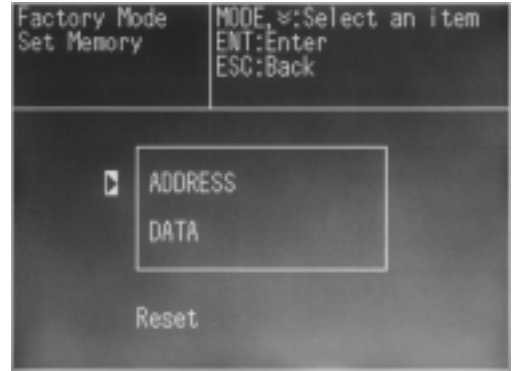

▪ Memory read/write

Move the cursor to the address to be written pressing the  key.





Enter the value using the  and  key.

Move the digit using the  key, and make the setting for each digit.

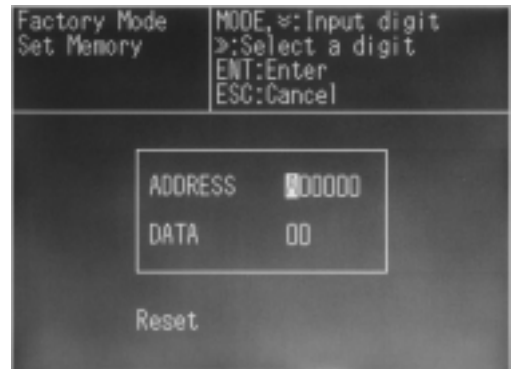
Data is displayed as the value to be written by specified address.



Press the  key, and the cursor moves to the value to be written.

Enter the value using the  and  keys.

Move the digit using the  key and make the setting for each digit.

Press the  key to confirm the setting.

Press the  key to cancel the setting.



▪ Soft reset

Move the cursor to “Reset” and then press the  key.

“Reset” is highlighted.

Press the  key again, and reset is carried out and the program is started from the beginning.



The measurement screen appears again.

Press the  key to cancel the reset.

### 3.3.13 Coefficient confirmation

**Function:** Displays zero offset and calibration coefficient.

**Operation:** The initial coefficient confirmation screen is shown at right.

Select the item to be set using the  and  keys.  
Press the  key to enter each display screen.

▪ When offset is selected

Display contents:

Offset .....Offset value of infrared ray detector and that of O<sub>2</sub> meter

Press the  key to return to the initial coefficient confirmation screen.



▪ When calibration coefficient is selected

Display contents:

Display is made by range.

Zero.....Zero calibration coefficient

Span .....Span calibration coefficient

Press the  and  keys to scroll the CH display.

Press the  key to return to the initial coefficient confirmation screen.

Note: You can check the coefficient but cannot change it in this mode.

Factory mode initial screen  
The cursor is in 13.

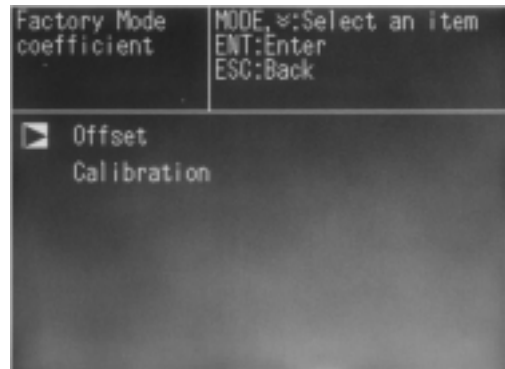

Factory Mode coefficient offset		Just watching ESC:Back	
	offset		
CH 1	40390		
CH 2	20076		
CH 3	20118		
CH 4	20106		
CH 5	24800		

Factory Mode Calibration		Just watching MODE, ⌘: Scroll ESC:Back	
CH	RANGE	ZERO	SPAN
CH 1 NO <sub>x</sub>	0-500ppm	01.0108	03.2374
	0-1000ppm	01.0108	03.2374
	0-2000ppm	01.0108	03.2374
CH 2 SO <sub>2</sub>	0-500ppm	01.1392	02.1439
	0-1000ppm	01.1392	02.1439
CH 3 CO <sub>2</sub>	0-5vol%	00.9918	01.2456
	0-10vol%	00.9918	01.2456
	0-20vol%	00.9918	01.2456

### 3.3.14 A/D data

**Function:** Measures the counter readings immediately after A/D conversion.

**Operation:** The A/D data screen is shown at right.

Press the  key to operate the pump and feed the gas.

Press the  key to return to the initial A/D data screen.

Note: You can check the count of input signals but cannot change the value in this mode.

Factory mode initial screen  
The cursor is in 14.



Factory Mode	Just watching	
A/D Data	MEAS: Pump ON/OFF	
	ESC: Back	
optical 1-1		40584
optical 1-2		37993
optical 2-1		40640
optical 2-2		41341
oxygen		24782
temperature		17411

### 3.3.15 Component display setting

**Function:** Used to measure the same components (2 optical systems).

**Operation:** Component display is shown at right.

Select a component to be set using the  $\nabla$  and  $\text{MODE}$  keys.

Press the  $\text{ENT}$  key, and the setting is highlighted.

Change the setting using the  $\nabla$  and  $\text{MODE}$  keys.

Press the  $\text{ENT}$  key to confirm the setting.

Press the  $\text{ESC}$  key not to confirm the setting.

**Setting contents:**

NO, NO<sub>x</sub>, SO<sub>2</sub>, CO<sub>2</sub>, CO, HC, C<sub>3</sub>H<sub>8</sub>, CH<sub>4</sub>, None

**Initial value:**

Same as those given in section “3.3.3 Number of channels (Measured component setting)”

Note: The component display set in section 3.3.3 “Number of channels” can be modified in this mode. The setting is required only for the measurement of the same components.

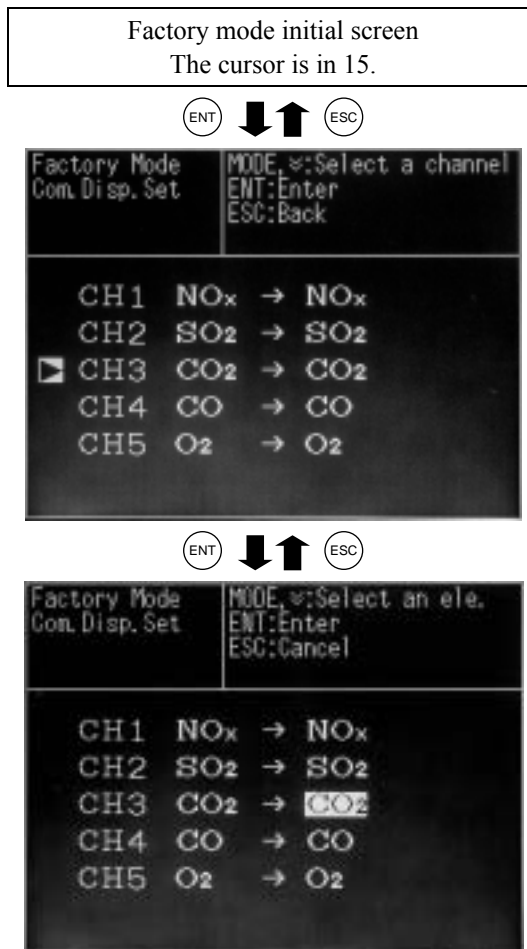

## 4. ERROR JUDGEMENT CRITERIA FOR ERROR CODES

\* This section covers the error judgement criteria for error codes.

For the contents of errors, refer to Instruction Manual.

Error No.	Contents	Criteria
Error 1	Motor rotation detector signal is faulty.	Detector signals generated due to motor chopping are converted into rectangular waves and rectangular waves are monitored. If waves are not generated or irregular, an error occurs.
Error 4	Zero calibration is not within the allowable range.	Infrared component: $0.7 \leq \text{zero calibration coefficient} \leq 4.0$ Paramagnetic oxygen: $-3000 \leq \text{zero calibration coefficient} \leq 3000$
Error 5	An amount of zero calibration is over 50% of full scale.	This error occurs in the following condition. $50\% \text{ of FS} < \{(\text{Zero calibration concentration set value}) - (\text{current display})\}$
Error 6	Span calibration is not within the allowable range.	When span calibration coefficient is not within the following range, error occurs. Infrared component: $0.5 \leq \text{span calibration coefficient} \leq 6$ Paramagnetic oxygen: $0.5 \leq \text{span calibration coefficient} \leq 10$
Error 7	An amount of span calibration is over 50% of full scale.	This error occurs in the following condition. $50\% \text{ of FS} < \{(\text{Span calibration concentration set value}) - (\text{current display})\}$
Error 8	Measured values fluctuate to much during zero and span calibration	Check if measured values fluctuate excessively during calibration. Infrared component, paramagnetic oxygen: When measured values are not stabilized in 60 seconds (a change of more than 100 counts is continued).

Main portions to be checked during error

Error No.	Main portions to be checked
Error 1	Sector motor rotation, light source, motherboard, and detector signal on amplifier printed circuit board. Rectangular waves between GND and MPD3 on main printed circuit board (10Hz, 5Vp-p)
Error 4	See service manual "5. (1) No zero calibration can be performed."
Error 5	See service manual "5. (1) No zero calibration can be performed."
Error 6	See service manual "5. (2) No span calibration can be performed."
Error 7	See service manual "5. (2) No span calibration can be performed."
Error 8	

# 5. COUNTERMEASURES AGAINST TROUBLE

## (1) No zero calibration can be performed

- 1) Check that a specified amount of zero gas is supplied to the gas analyzer main unit.  
Also check that the zero gas pot is filled with clear water. (ZSVF)  
→ Locate a gas leaked portion and remedy.
- 2) Check if detector signal is as specified (based on result of detector signal checked on amplifier printed circuit board).  
→ Adjust detector signals. If a check cannot be made on signals, check the detector.  
Record voltage when zero gas is supplied and check the detector voltage.
- 3) Check the A/D data against the display (see Factory mode and A/D data).  
→ Check voltage at the main printed circuit board. Check the switching power supply. Record the A/D data when zero gas is supplied.

## (2) No span calibration can be performed

- 1) Check that span gas concentration and span concentration settings are the same.
- 2) Check that specified amount of span gas is supplied to the gas analyzer main unit.  
→ Locate a gas leaked portion and remedy.
- 3) Check that zero calibration can be properly performed.  
→ If zero calibration can not be performed, repeat the procedure “1) No zero calibration can be performed.”
- 4) Check if detector signal is as specified (based on result of detector signal checked on amplifier printed circuit board).  
→ Record voltage when span gas is supplied (to compare with the voltage when zero gas is supplied).  
Check the detector and detector voltage.
- 5) Check the A/D data against the display (see Factory mode and A/D data).  
→ Check voltage at the main printed circuit board. Check the switching power supply. Record the A/D data when span gas is supplied.

## (3) Drift

- 1) Check that specified amount of measured gas is supplied to the gas analyzer main unit.  
→ Locate a gas leaked portion and remedy.
- 2) Check that the cell window, O-ring, detector window and cell inside are not contaminated.  
→ Clean the cell and window. Replace parts.

## (4) Readings are high or low too much.

- 1) Check that a large quantity of interference components (moisture) is not contained in sampling gas.  
→ Check the components of the measured gas. (Check it with the user.)

**(5) Readings are not increased**

- 1) Check that specified amount of measured gases are supplied to the gas analyzer main unit.  
→ Locate a gas leaked portion and remedy.
- 2) Check that zero and span calibration can be performed.  
→ If possible, check for sampling gas (related to measured gas) and take remedies.  
→ If not possible, check the procedure (1) and (2).



## 6. ADJUSTMENT IN HEAT TREATMENT FURNACE

### • What is the adjustment in heat treatment furnaces?

If, in plant gases to be measured actually, a large amount of other lower-molecular-weight gases than nitrogen (N<sub>2</sub>) such as hydrogen (H<sub>2</sub>), or a large amount of other higher-molecular-weight gases than nitrogen (N<sub>2</sub>) such as argon (Ar) are contained, including the measuring components, it is known that the calibration curve (output performance to gas concentration) of the gas analyzers will be affected (pressure broadening).

In such a case, the gas analyzer is adjusted with gases similar to plant gas compositions in manufacturing (adjustment by scale gas). After this adjustment, the gas analyzer is checked the calibration curve with N<sub>2</sub> balance gas (calibration curve by check gas). Graphs with these calibration curves drawn are attached to products to be supplied.

Since measurement in a heat treatment furnace has much gas of such composition, adjustment in heat treatment furnaces is performed.

In order to perform exact measurement, there are two methods in span calibration:

Composition of the standard gas for span calibration used for each method and its method are explained using an example. For the standard gas for zero calibration, use N<sub>2</sub> or Air in any case so that zero point will not be affected.

#### <Example>

Assume that a 0 to 1% CO<sub>2</sub> meter of the infrared gas analyzer measures CO<sub>2</sub> contained in plant gases.

When plant gases are composed of 0.5% CO<sub>2</sub>, 25% CO, 30% H<sub>2</sub>, 0.2% CH<sub>4</sub> and 44.3% N<sub>2</sub>, either of the following is used as the span calibration standard gas.

	Standard gas type	Composition of standard gas	Method for span adjustment
1	Standard gas with the same composition as plant gases (scale gas)	0.9% to 1% CO <sub>2</sub> 25% CO, 30% H <sub>2</sub> , remainder is N <sub>2</sub> *	Perform span calibration directly.
2	Check gas	0.9% to 1% CO Remainder is N <sub>2</sub> .	Perform span calibration indirectly.

\* A gas in small amount that has little effect on span calibration such as 0.2%CH<sub>4</sub> is not included.

### (1) Method for span calibration by standard gas with the same composition as plant gas

When using the standard gas with the same composition as plant gases given in 1, calibration can be performed without correction, as an error in calibration curve does not occur.

- 1) Set CO<sub>2</sub> concentration to span calibration concentration set value.
- 2) Perform span calibration by using the operation key.

## (2) Method for span calibration by check gas

Span calibration is performed as follows when two kinds of check gas are used. (Since span calibration has an error of calibration curve, preset a calibration indication on the calibration curve graph attached to this gas analyzer for indirect calibration.)

- 1) The following calibration curve graph is attached to the test results for the product. In graph, the calibration curve by the scale gas (that is similar to plant gas and determines scales of this gas analyzer) and the calibration curve by the check gas that is adjusted by the scale gas (gas of simple composition of N<sub>2</sub> balance gas to facilitate the gas analyzer check) are drawn.

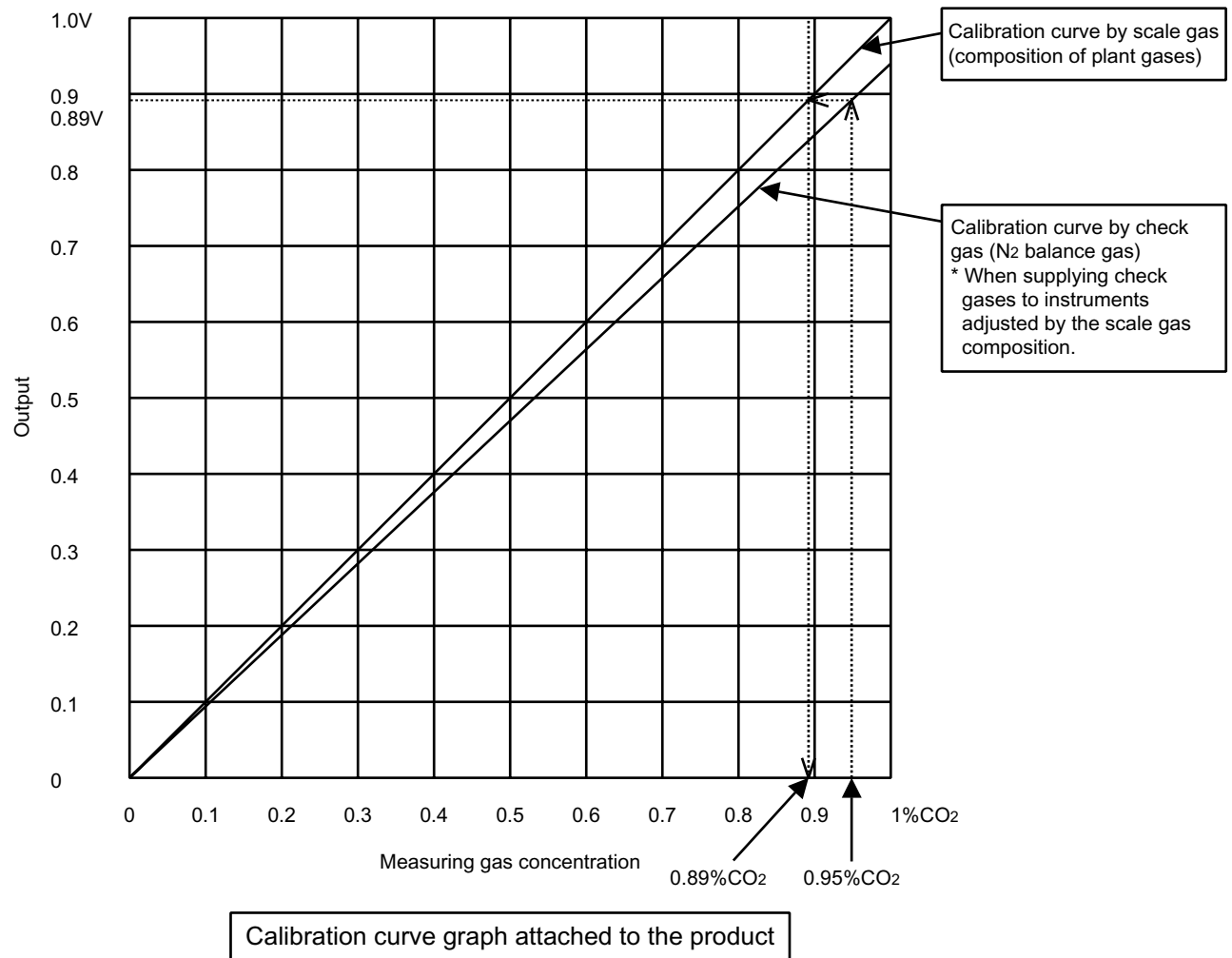

- 2) When using 0.95% CO<sub>2</sub> and remainder N<sub>2</sub> (check gas) as calibration gas, in graph, a point of 0.95% on X-axis should be stretched to upward, draw a line toward Y-axis from the cross point with the check gas calibration curve. From the cross point with calibration curve on the scale gas composition, 0.89% or equivalent values can be obtained.
- 3) Set this point (0.89%) to the span calibration concentration of the calibration concentration set value.
- 4) Supply 0.95% check gas to perform span calibration. Then, the concentration value is corrected to 0.89%. Measurement suited to actual plants can be performed by this error correction of calibration curve.

# 7. MEASURING PRINCIPLE DIAGRAM

## (1) Infrared ray type (NO, SO<sub>2</sub>, CO<sub>2</sub>, CO, and CH<sub>4</sub>)

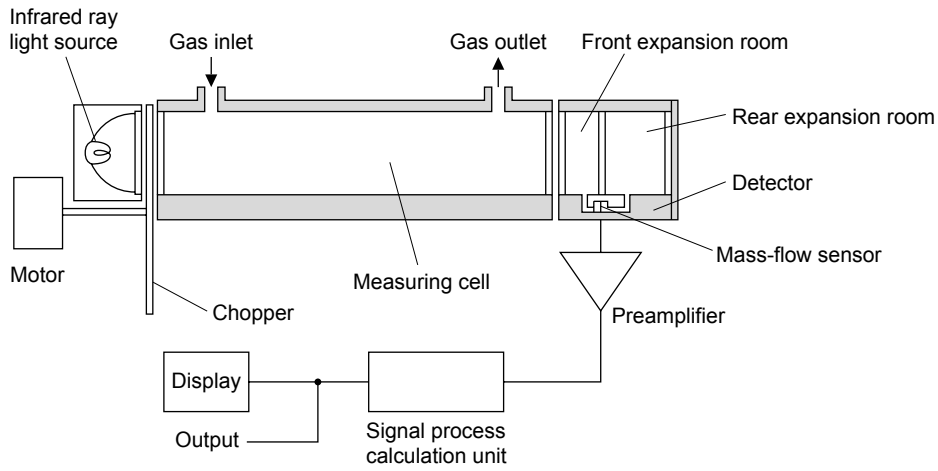

## (2) Paramagnetic type (O<sub>2</sub>)

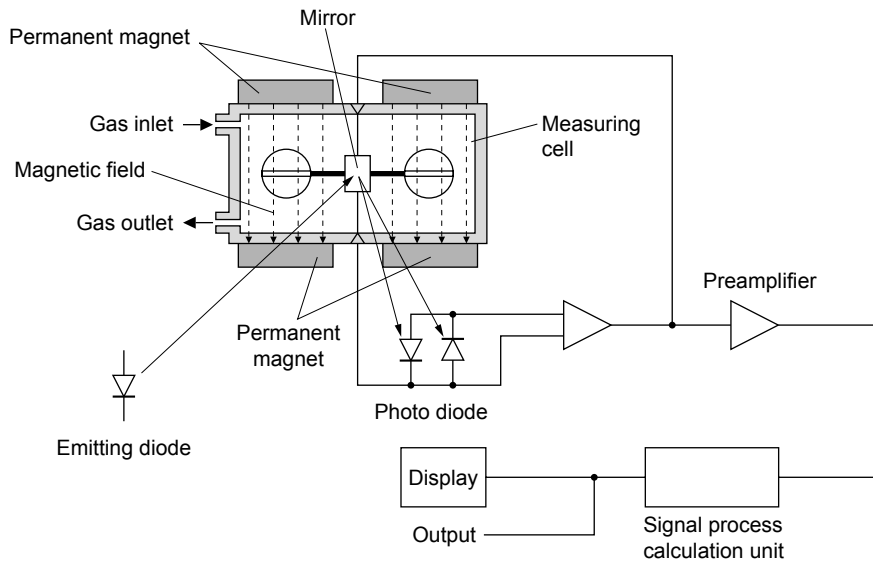

## (3) Galvanic type (O<sub>2</sub>)

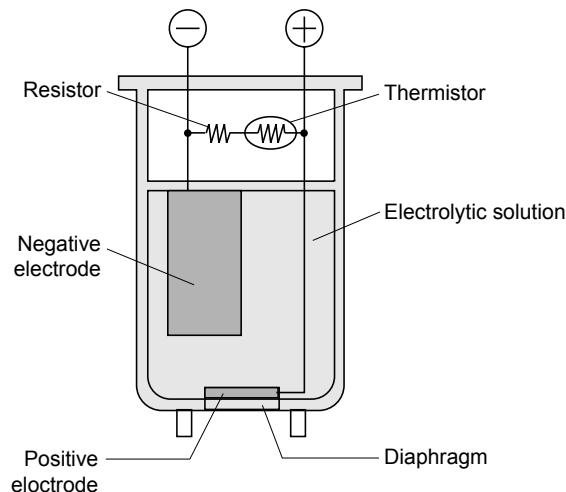

# 8. SOFT FLOW CHART

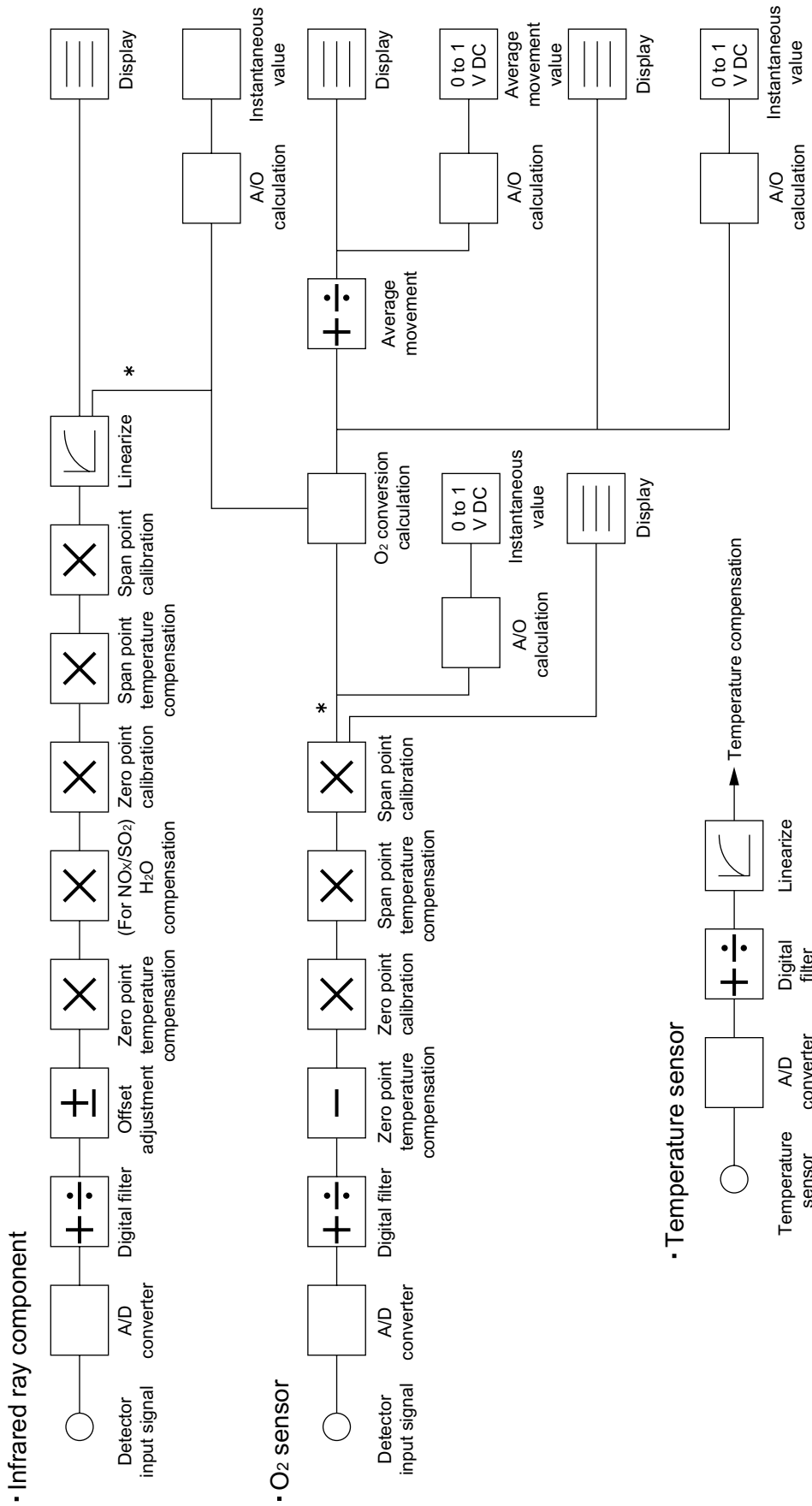

Note 1) Asterisk mark \* indicates "Hold point."

# 9. INTERNAL WIRING DIAGRAM

## 9.1 Analyzer unit

### 9.1.1 Analyzer unit (ZSVF)

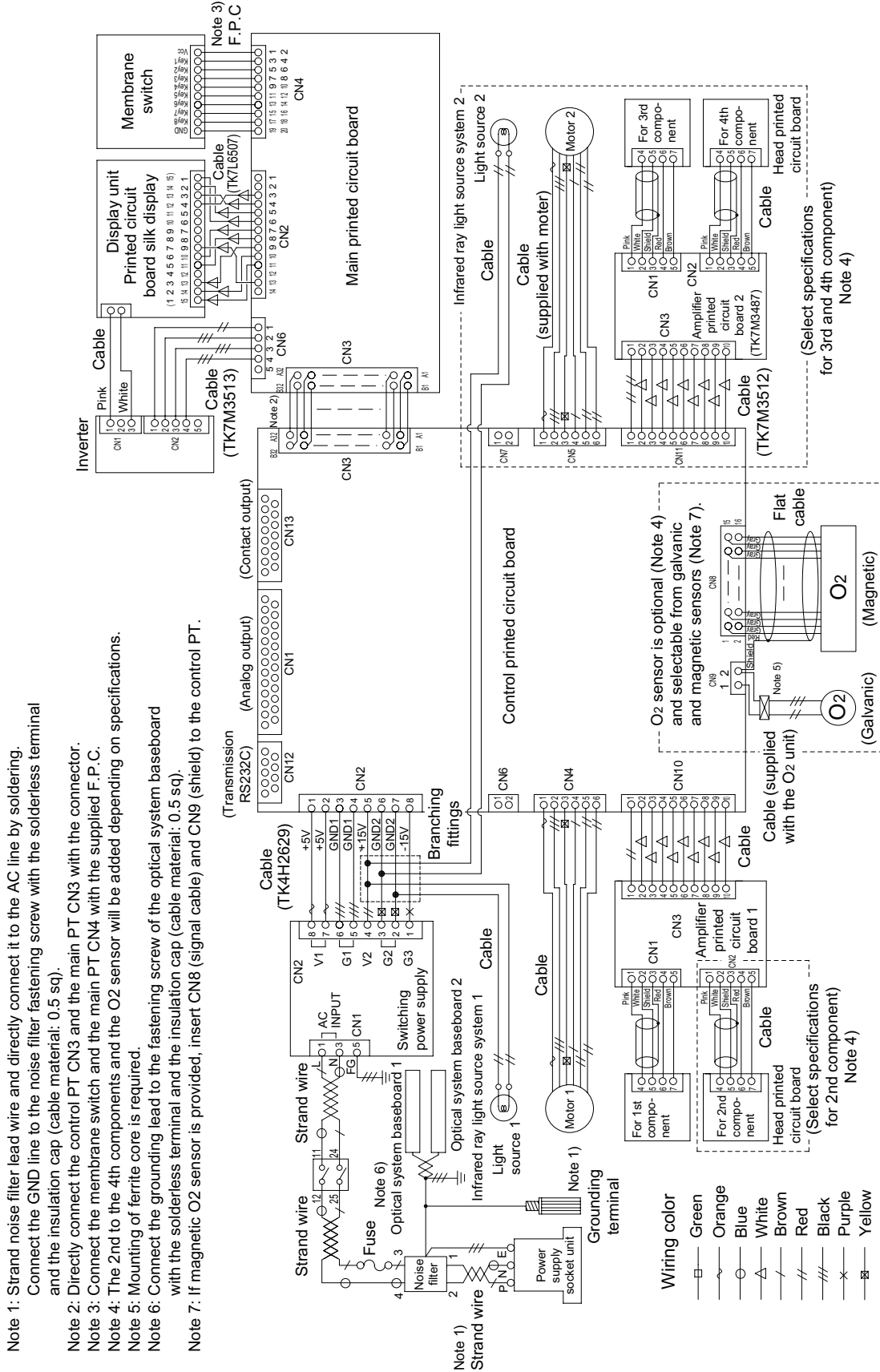

## 9.1.2 Analyzer unit (ZSVS)

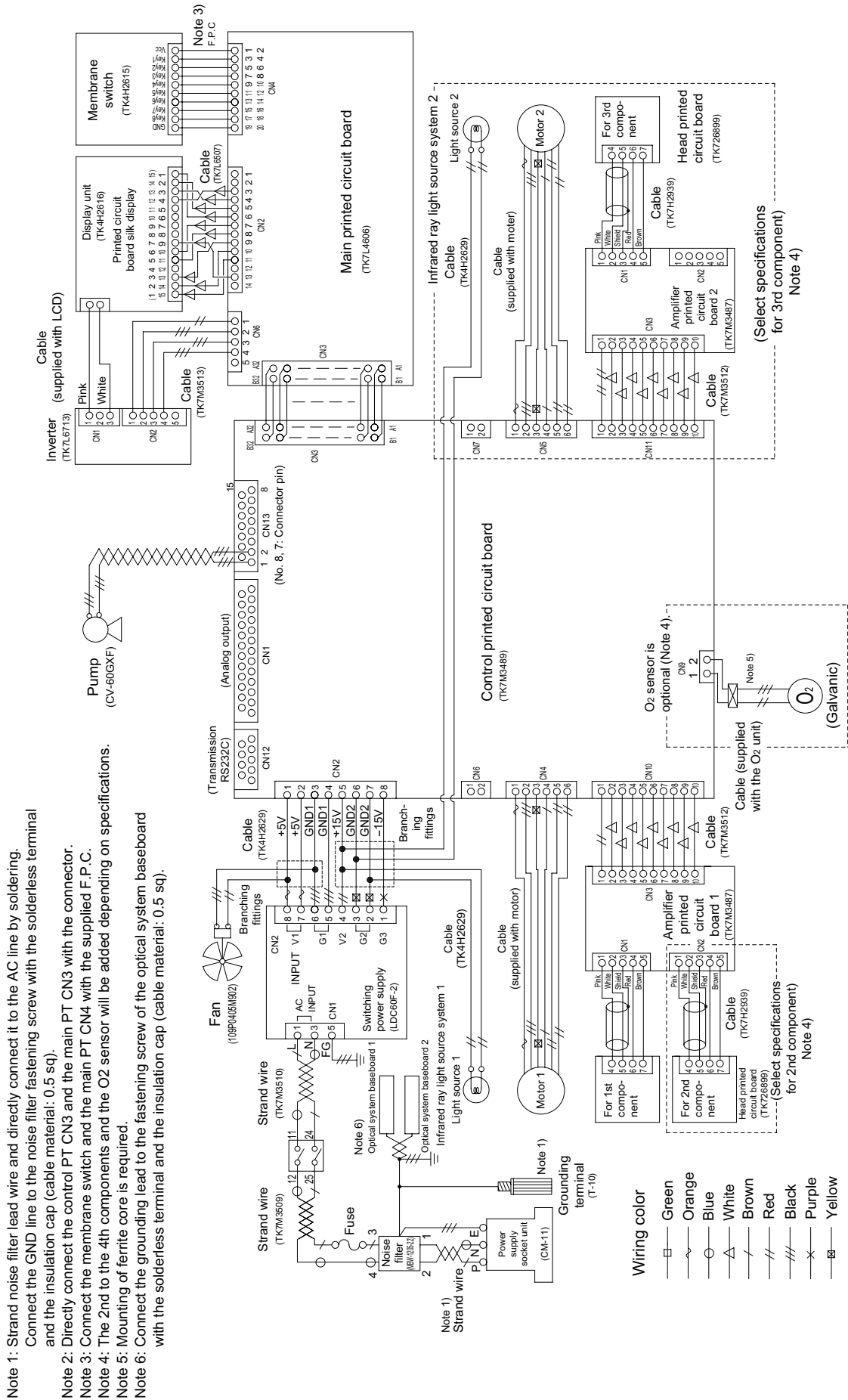

## 9.2 Sampling unit

- Note 1: Strand noise filter lead wire and directly connect it to the AC line by soldering.  
Connect the GND line to the noise filter fastening screw with the solderless terminal and the insulation cap (cable material: 0.5 sq).
- Note 2: The converter is or is not provided depending on specifications.

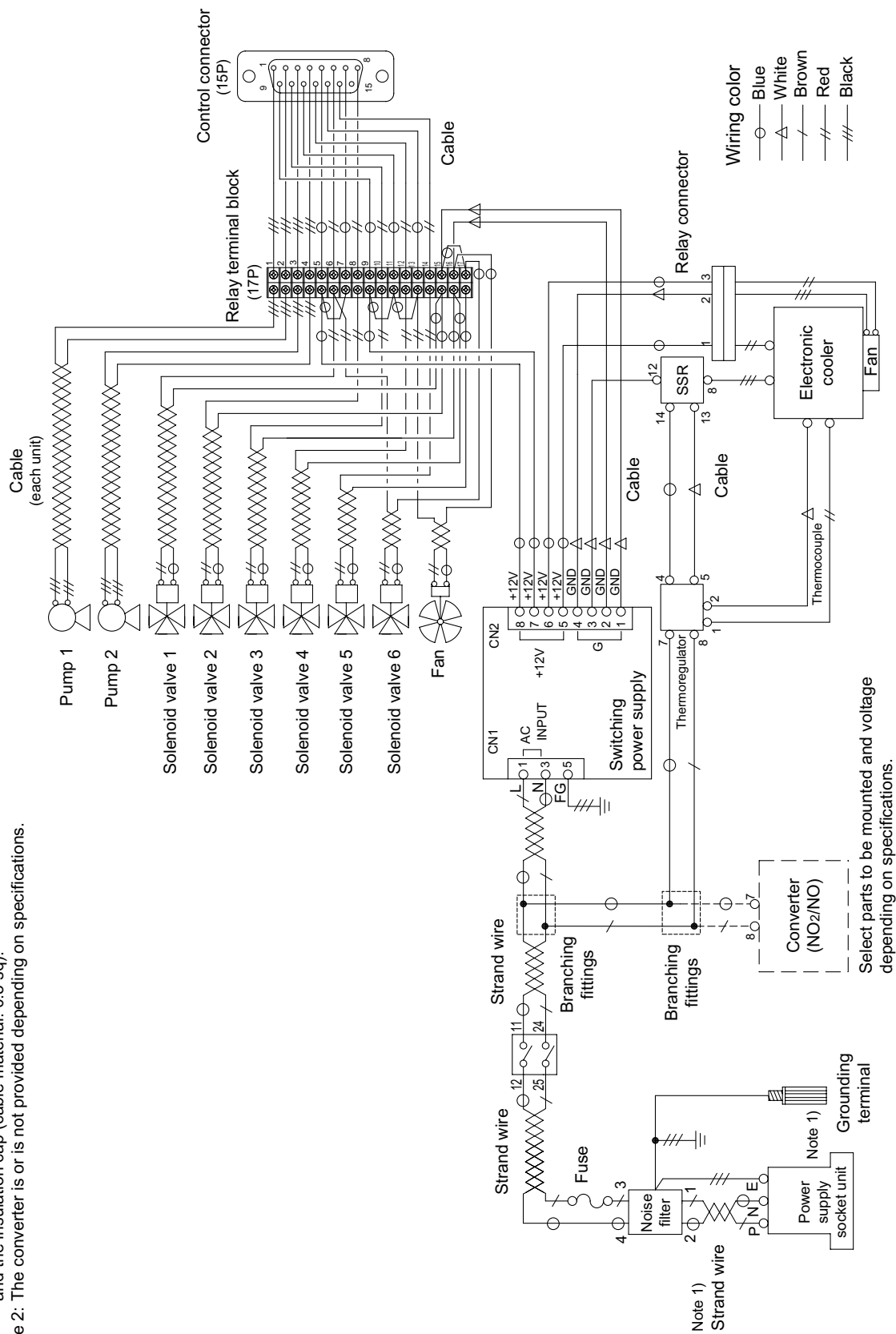

# 10. INTERNAL PIPING

## 10.1 Analyzer unit

### 10.1.1 Analyzer unit (ZSVF)

#### 10.1.1.1 System 1

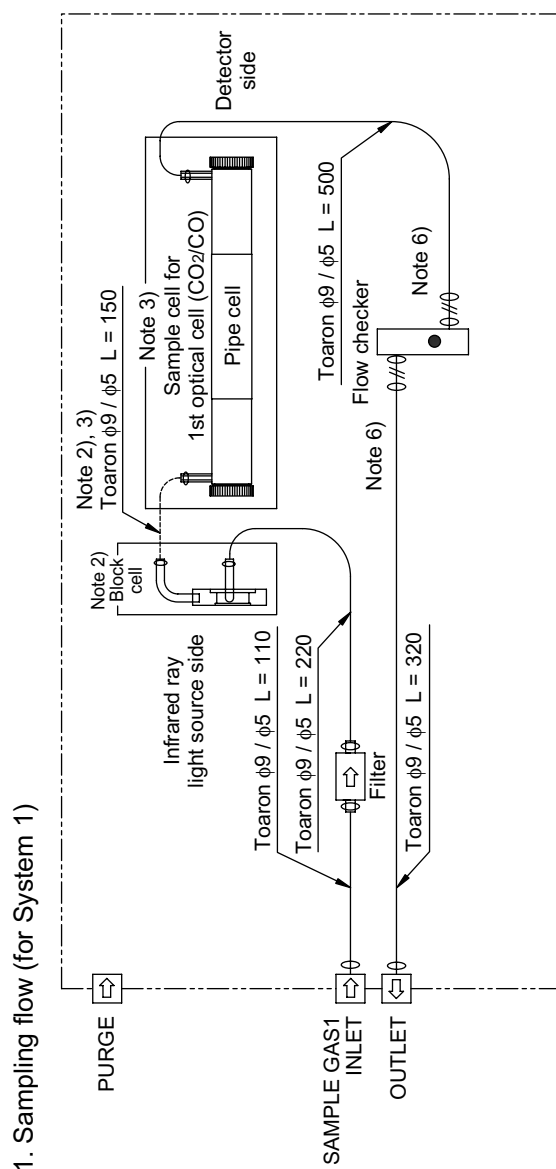

#### 2. Pipe material

Name	Pipe diameter	Drawing No./ Material code	Quantity	Symbol
Toaron	φ9/φ5	TK727528P1	1300 mm	
Hose band	φ8	TK712007P1	10 or 12 pieces	0
Filter	φ6/φ4	TK7L8925P1	1 piece	
Teflon	φ6/φ4	415536P4	30 mm x 2	—#—

#### 3. Note:

- Airtightness should be maintained. Airtight specifications vary depending on the product standard.
- A block cell is or is not provided for the 1st optical cell depending on the specifications of the range.  
(If the block cell is not provided, "Toaron L = 150" piping is not required.)
- A pipe cell is or is not provided for the 1st optical cell depending on the specifications of the range.  
(If the pipe cell is not provided, "Toaron L = 150" piping is not required.)
- If 3 gas ports are provided, use TK7M3891 (additional gas port processing).
- Pipe dimensional tolerance: ±10
- Use a Teflon pipe as a connecting pipe at the inlet/outlet of the flowmeter.



## 10.1.1.2 System 2

### 1. Sampling flow (for System 2)

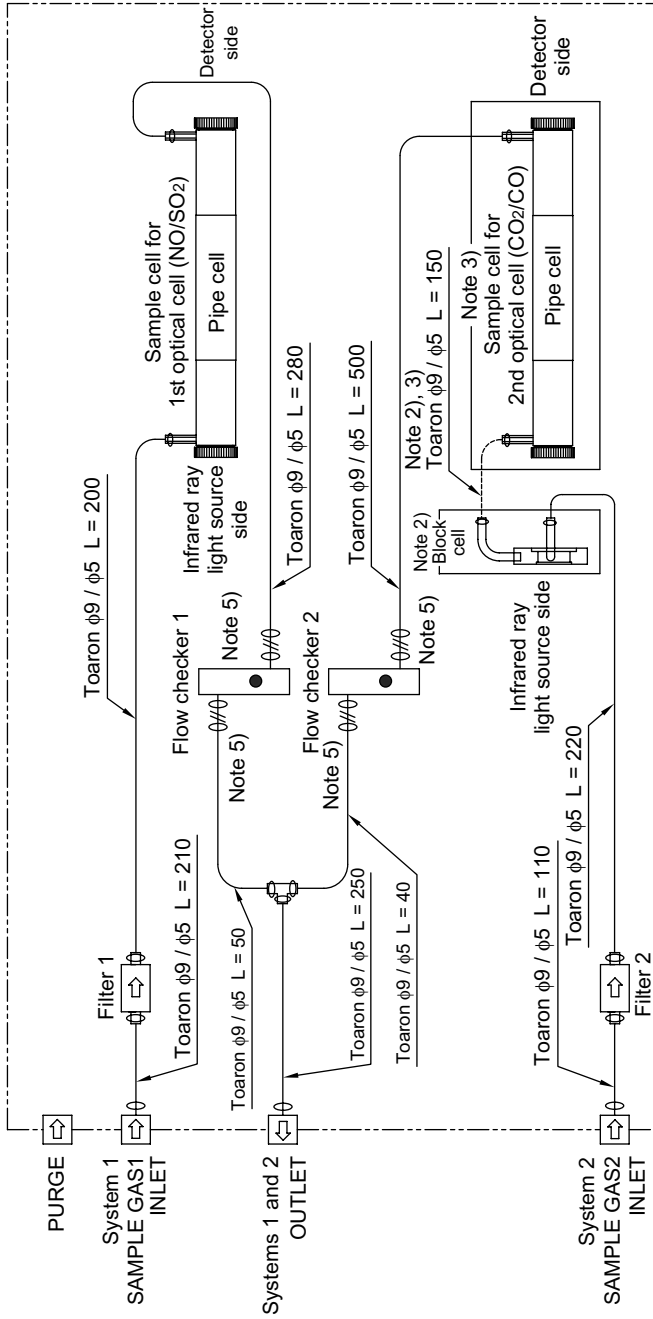

### 2. Pipe material

Name	Pipe diameter	Quantity	Symbol
Toaron	φ9/φ5	TK727528P1	
Hose band	φ8	TK712007P1	22 or 24 pieces
Pipe tee	φ6/φ4	TK709061P1	1 piece
Filter	φ6/φ4	TK7L8925P1	2 pieces
Teflon	φ6/φ4	415536P4	30 mm x 2

### 3. Note:

1. Airtightness should be maintained. Airtight specifications vary depending on the product standard.
2. A block cell is or is not provided for the 2nd optical cell depending on the specifications of the range.  
(If the block cell is not provided, "Toaron L = 150" piping is not required.)
3. A pipe cell is or is not provided for the 1st optical cell depending on the specifications of the range.  
(If the pipe cell is not provided, "Toaron L = 150" piping is not required.)
4. Pipe dimensional tolerance: ±10
5. Use a Teflon pipe as a connecting pipe at the inlet/outlet of the flowmeter.

### 10.1.1.3 System 1 with O<sub>2</sub>

#### 1. Sampling flow (for System 1 with O<sub>2</sub>)

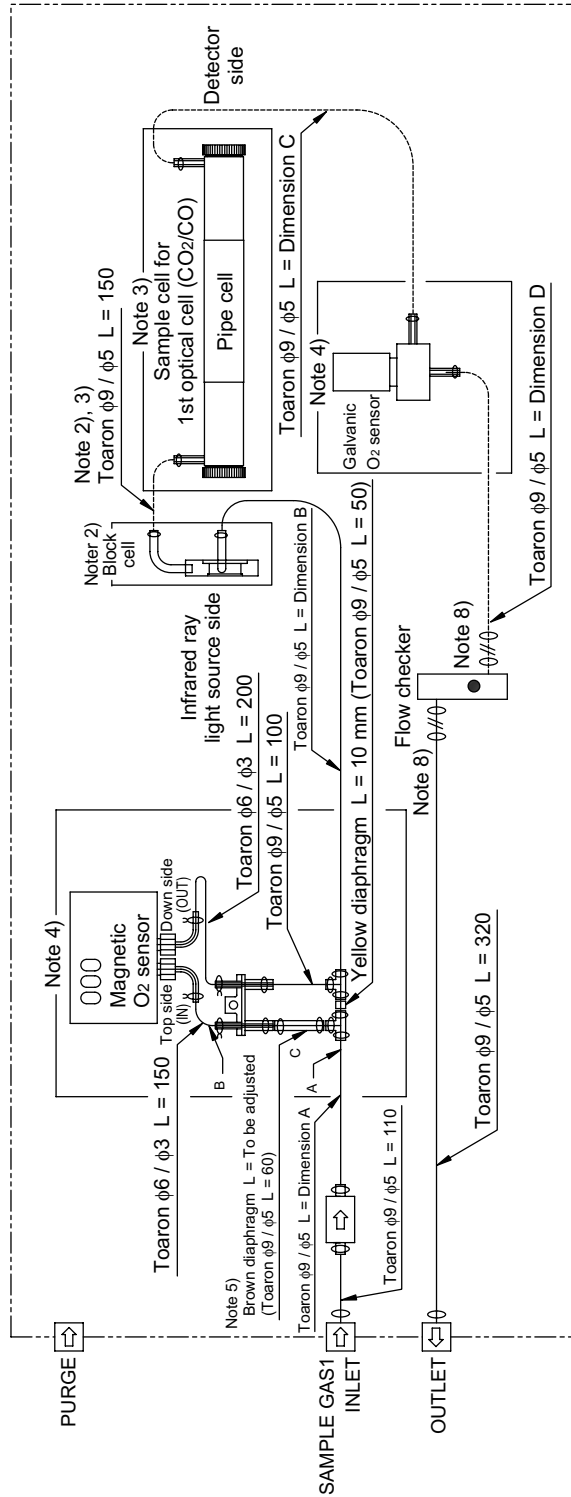

#### 2. Pipe material

Name	Pipe diameter	Quantity	Symbol
Toaron	φ9 / φ5	1490 mm (Magnetic) 1300 mm (Galvanic)	
Toaron	φ6 / φ3	350 mm (Magnetic)	
Hose band	φ8	21, 19, 14, 12 pieces	
Hose band	φ5	Varies depending on specifications (4 pieces)	
Pipe tee	φ6 / φ4	Varies depending on specifications (2 pieces)	
Coupling	φ6 → φ4	Varies depending on specifications (1 piece)	
Diaphragm (Yellow)	φ6 / φ1.4	10 mm	
Diaphragm (Brown)	φ6 → φ1	Adjust.	
Filter	φ6 / φ4	1 piece	
Teflon	φ6 / φ4	30 mm x 2	

#### 3. Note:

- Airtightness should be maintained. Airtight specifications vary depending on the product standard.
- A block cell is or is not provided for the 1st optical cell depending on the specifications of the range.  
(If the block cell is not provided, "Toaron L = 150" piping is not required.)
- A pipe cell is or is not provided for the 1st optical cell depending on the specifications of the range.  
(If the pipe cell is not provided, "Toaron L = 150" piping is not required.)
- O<sub>2</sub> sensor is optionally available. Select "magnetic" or "galvanic" system on the PLC code table.
- When magnetic type O<sub>2</sub> sensor is mounted, adjust the length of the fixed diaphragm. (Feed the gas of 1 L/min/10 kPa from part "A" and adjust the length of the fixed diaphragm at "C" so that part "B" falls within 100 mL/min ±20 mL range.)
- If 3 gas ports are provided, use TK7M3891 (additional gas port processing).
- Pipe dimensional tolerance: ±10
- Use a Teflon pipe as a connecting pipe at the inlet/outlet of the flowmeter.

#### Pipe dimensions by O<sub>2</sub> sensor

	Magnetic O <sub>2</sub> sensor	Galvanic O <sub>2</sub> sensor
Dimension A	100 mm	200 mm
Dimension B	140 mm	
Dimension C	460 mm	300 mm
Dimension D		220 mm

# 10.1.1.4 System 2 with O<sub>2</sub>

1. Sampling flow (for System 2 with O<sub>2</sub>)

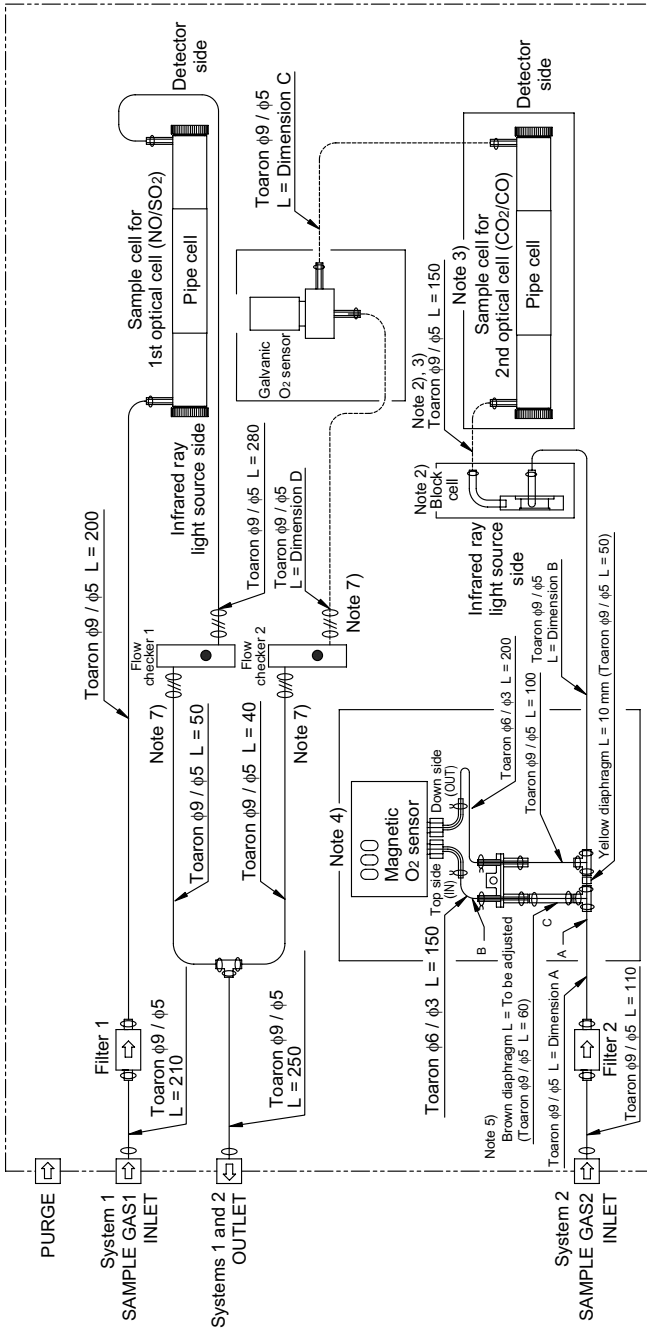

## 2. Pipe material

Name	Pipe diameter	Quantity	Symbol
Toaron	φ9 / φ5	2150 mm (Magnetic) 2010 mm (Galvanic)	
Toaron	φ6 / φ3	350 mm (Magnetic)	
Hose band	φ8	33, 31, 26, 24 pieces	
Hose band	φ5	Varies depending on specifications (4 pieces)	
Cheese pipe	φ6 / φ4	Varies depending on specifications 1 (+ 2) piece(s)	
Coupling	φ6 → φ4	Varies depending on specifications (1 piece)	
Diaphragm (Yellow)	φ6 / φ1.4	10 mm	
Diaphragm (Brown)	φ6 → φ1	Adjust.	
Filter	φ6 / φ4	2	
Teflon	φ6 / φ4	30 mm x 2	

## 3. Note:

- Airtightness should be maintained. Airtight specifications vary depending on the product standard.
- A block cell is or is not provided for the 2nd optical cell depending on the specifications of the range.  
(If the block cell is not provided, "Toaron L = 150" piping is not required.)
- A pipe cell is or is not provided for the 2nd optical cell depending on the specifications of the range.  
(If the pipe cell is not provided, "Toaron L = 150" piping is not required.)
- O<sub>2</sub> sensor is optionally available. Select "magnetic" or "galvanic" system on the PILC code table.
- When magnetic type O<sub>2</sub> sensor is mounted, adjust the length of the fixed diaphragm. (Feed the gas of 1 L/min/10 kPa from part "A" and adjust the length of the fixed diaphragm at "C" so that part "B" falls within 100 mL/min ± 20 mL range.)
- Pipe dimensional tolerance: ± 10
- Use a Teflon pipe as a connecting pipe at the inlet/outlet of the flowmeter.

## Pipe dimensions by O<sub>2</sub> sensor

	Magnetic O <sub>2</sub> sensor	Galvanic O <sub>2</sub> sensor
Dimension A	100 mm	200 mm
Dimension B	140 mm	
Dimension C	460 mm	300 mm
Dimension D		220 mm

## 10.1.2 Analyzer unit (ZSVS)

### 10.1.2.1 System 1

#### 1. Sampling flow (for 1st optical system)

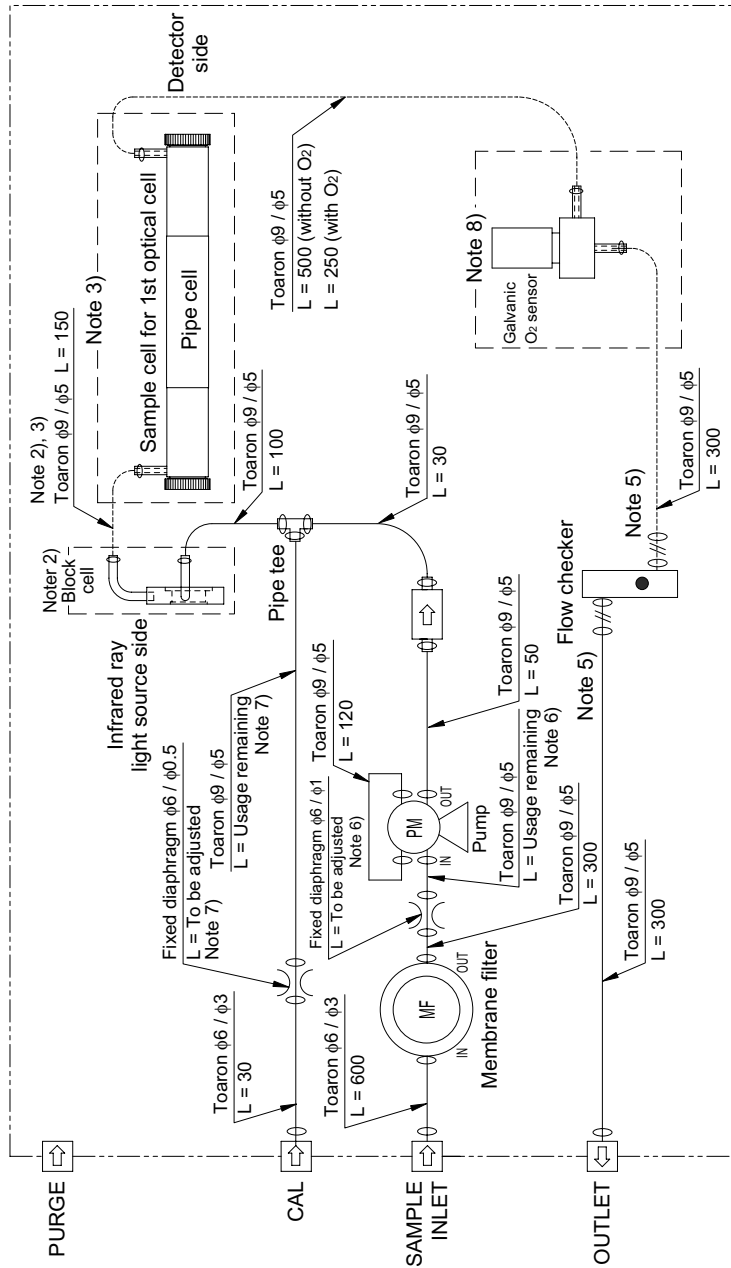

#### 2. Pipe material

Name	Pipe diameter	Drawing No./ Material code	Quantity	Symbol
Toaron	φ9 / φ5	TK727528P1	2270 mm	
Hose band	φ8	TK712007P1	24 to 28 pieces	0
Filter	φ6 / φ4	TK7L8925P1	1 piece	
Teflon	φ6 / φ4	415536P4	30 mm x 2	—#—
Fixed diaphragm	φ6 / φ1	TK729263P3	Adjust.	
Fixed diaphragm	φ6 / φ0.5	TK729263P1	Adjust.	
Membrane filter	φ6 / φ4	TK7B2375C3	1 piece	MF
Double magnetic pump	φ6 / φ4	TK7M3503C2	1 piece	PM
Pipe tee	φ6 / φ4	TK709061P1	1 piece	

#### 3. Note:

- Airtightness should be maintained. Airtight specifications vary depending on the product standard.
- A block cell is or is not provided for the 1st optical cell depending on the specifications of the range.  
(If the block cell is not provided, "Toaron L = 150" piping is not required.)
- A pipe cell is or is not provided for the 1st optical cell depending on the specifications of the range.  
(If the pipe cell is not provided, "Toaron L = 150" piping is not required.)
- Pipe dimensional tolerance: ±10
- Use a Teflon pipe as a connecting pipe at the inlet/outlet of the flowmeter.
- Adjust the length of the fixed diaphragm so that the flow rate is kept at 0.7 L/min (top of the yellow zone) when the pump is ON.
- Adjust the length between the diaphragm and the filter using a Toaron tube. Feed the gas at 0.03 MPa from the CAL gas port, and adjust the length of the fixed diaphragm so that the exhaust velocity is kept at 0.5 L/min.
- Galvanic type O<sub>2</sub> sensor is optionally available. Select it on the PILC code table. Note that the pipe length is not the same.

## 10.1.2.2 System 2

### 2. Pipe material

Name	Pipe diameter	Drawing No./ Material code	Quantity	Symbol
Toaron	$\phi 9 / \phi 5$	TK727528P1	2270 mm	
Hose band	$\phi 8$	TK712007P1	24 to 28 pieces	0
Filter	$\phi 6 / \phi 4$	TK7L8925P1	1 piece	
Teflon	$\phi 6 / \phi 4$	415536P4	30 mm x 2	—
Fixed diaphragm	$\phi 6 / \phi 1$	TK729263P3	Adjust.	
Fixed diaphragm	$\phi 6 / \phi 0.5$	TK729263P1	Adjust.	
Membrane filter	$\phi 6 / \phi 4$	TK7B2375C3	1 piece	MF
Double magnetic pump	$\phi 6 / \phi 4$	TK7M3503C2	1 piece	PM
Pipe tee	$\phi 6 / \phi 4$	TK709061P1	1 piece	

### 3. Note:

- Airtightness should be maintained. Airtight specifications vary depending on the product standard.
- A block cell is or is not provided for the 1st optical cell depending on the specifications of the range.
- A pipe cell is or is not provided, "Toaron L = 150" piping is not required, (if the block cell is not provided, "Toaron L = 150" piping is not required.)
- A pipe cell is or is not provided for the 1st optical cell depending on the specifications of the range.
- If the pipe cell is not provided, "Toaron L = 150" piping is not required.
- Pipe dimensional tolerance:  $\pm 10$
- Use a Teflon pipe as a connecting pipe at the inlet/outlet of the flowmeter.
- Adjust the length of the fixed diaphragm so that the flow rate is kept at 0.7 L/min (top of the yellow zone) when the pump is ON.
- Adjust the length between the diaphragm and the filter using a Toaron tube. Feed the gas at 0.07 MPa from the CAL gas port, and adjust the length of the fixed diaphragm so that the exhaust velocity is kept at 0.5 L/min.
- Galvanic type O<sub>2</sub> sensor is optionally available. Select it on the PLC code table. Note that the pipe length is not the same.

### 1. Sampling flow (for 2nd optical system)

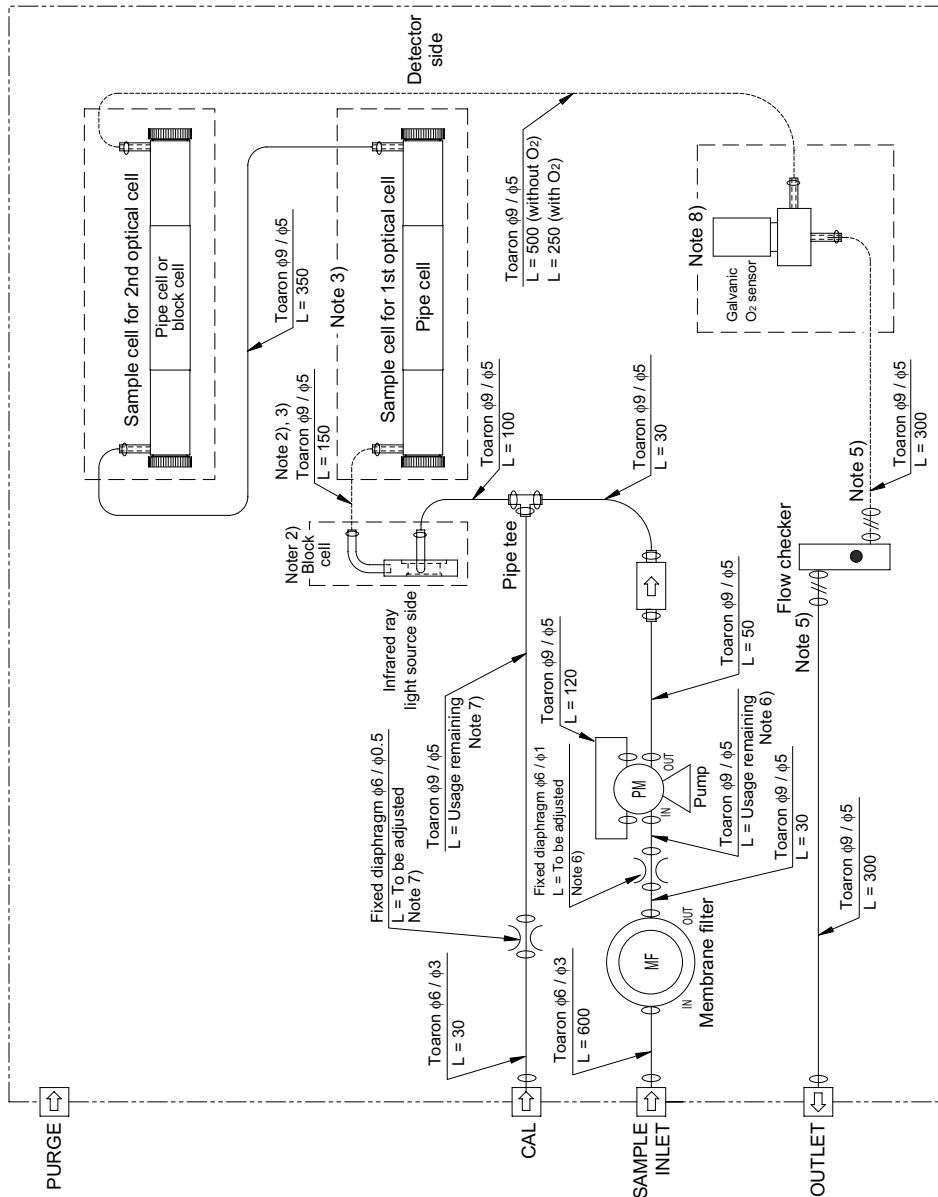

## 10.2 Sampling unit

### 10.2.1 Outlet 1 system (1-component or 2-component meter excluding NO<sub>x</sub> meter)

#### 1. Pipe material

Name	Pipe diameter	Quantity	Symbol
Toaron	φ9 / φ5	6920 mm	— / —
Teflon	φ6 / φ4	170 mm	— / —
Diaphragm	φ6 / φ1	50 mm	— / —
Hose band	φ8	52	0
Membrane filter	φ6 / φ4	2	MF1, 2
Demister	RC1/4	1	DS
Mist filter	RC1/4	1	MSF
Drain pot	RC1/4	2	DP
Electronic dehumidifier		1	CL
Double solenoid pump	φ6 / φ4	2	PM
Bidirectional solenoid valve for calibration	RC1/4	1	SV5
Bidirectional anticorrosion solenoid valve	RC1/4	4	SV2, 3, 4, 6
Three-way anticorrosion solenoid valve	RC1/4	1	SV1
Coupling	RC1/4	1	
Cheese pipe	φ6 / φ4	3	
Nipple	RC1/4	19	
Zero filter	φ6	(1)	
Through nipple	RC1/4	1	
Blank plug for H <sub>2</sub> O refilling	RC1/4	1	
Needle valve	φ6 / φ4	1	NV
Connection port	φ13 / φ9	1	
Elbow	φ6 / φ4	1	
Hose band	φ11	1	0

- Note:  
The pipe length is a reference value.

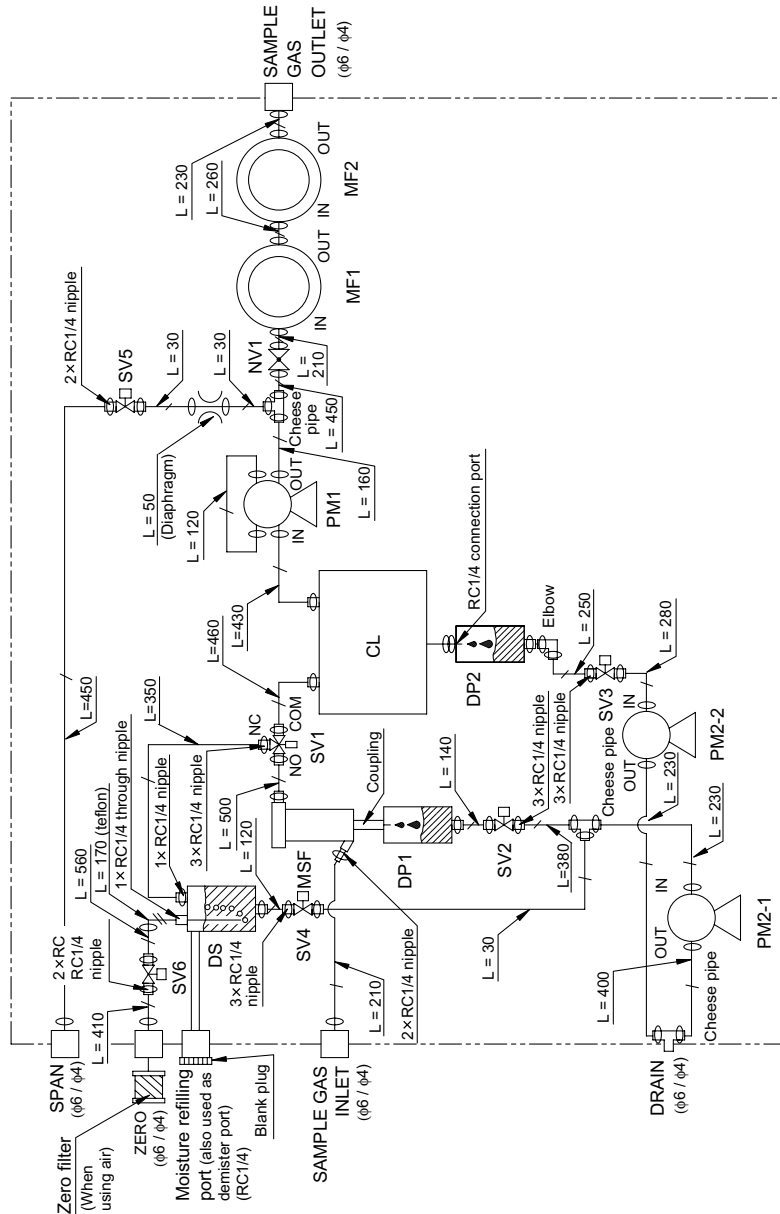

## 10.2.2 Outlet 2 system (2-component to 4-component meter excluding NO<sub>x</sub> meter)

### 1. Pipe material

Name	Pipe diameter	Quantity	Symbol
Toaron	φ9 / φ5	7610 mm	—
Teflon	φ6 / φ4	170 mm	—
Diaphragm	φ6 / φ1	50 mm	⊗
Hose band	φ8	2	0
Membrane filter	φ6 / φ4	2	MF1, 2
Demister	RC1/4	1	DS
Mist filter	RC1/4	1	MSF
Drain pot	RC1/4	2	DP
Electronic dehumidifier		1	CL
Double solenoid pump	φ6 / φ4	2	PM
Bidirectional solenoid valve for calibration	RC1/4	1	SV5
Bidirectional anticorrosion solenoid valve	RC1/4	4	SV2, 3, 4, 6
Three-way anticorrosion solenoid valve	RC1/4	1	SV1
Coupling	RC1/4	1	
Cheese pipe	φ6 / φ4	4	
Nipple	RC1/4	19	
Zero filter	φ6	(1)	
Through nipple	RC1/4	1	
Blank plug for H <sub>2</sub> O refilling	RC1/4	1	
Needle valve	φ6 / φ4	2	NV
Connection port	φ13 / φ9	1	
Elbow	φ6 / φ4	1	
Hose band	φ11	1	⑩

2. Note:  
The pipe length is a reference value.

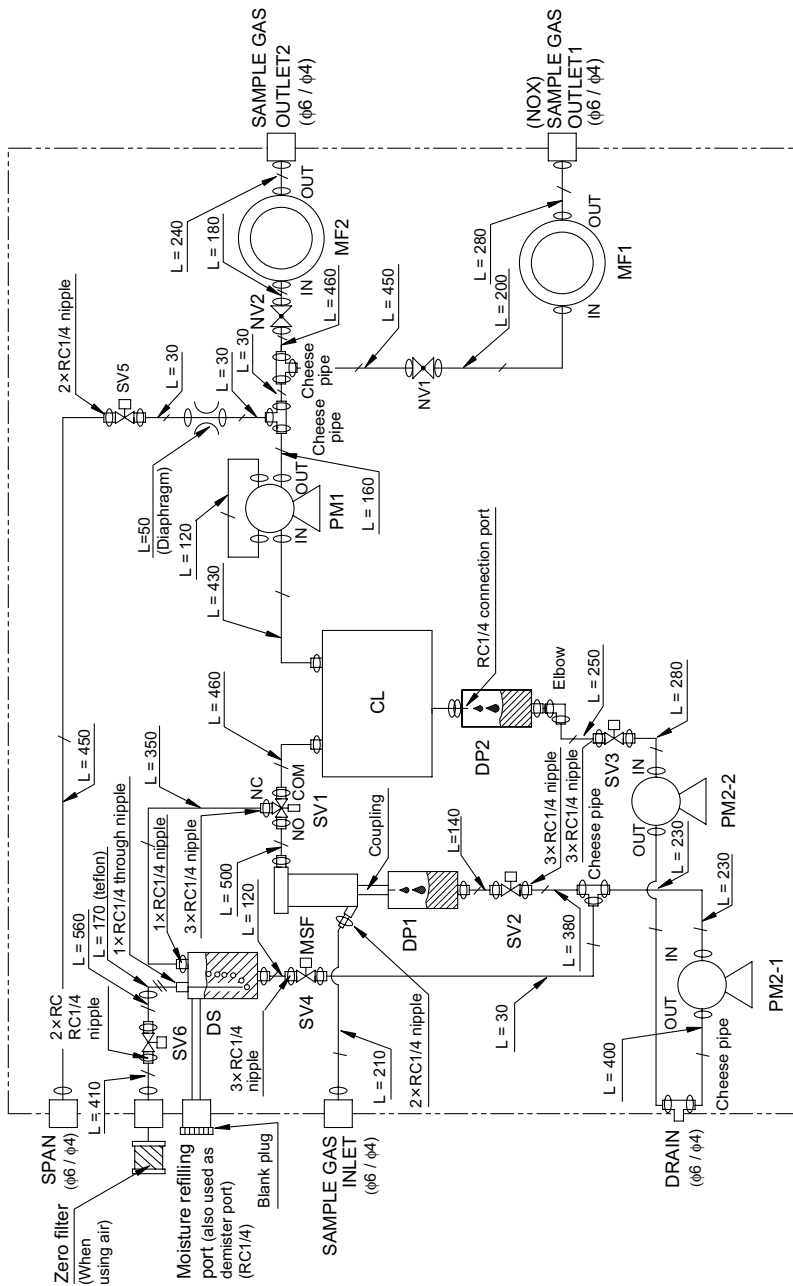

## 10.2.3 Outlet 1 system (1-component or 2-component meter including NO<sub>x</sub> meter)

### 1. Pipe material

Name	Pipe diameter	Quantity	Symbol
Toaron	φ9 / φ5	7680 mm	—
Teflon	φ6 / φ4	205 mm	—
Diaphragm	φ6 / φ1	50 mm	—
Hose band	φ8	56	0
Membrane filter	φ6 / φ4	2	MF1, 2
Demister	RC1/4	1	DS
Mist filter	RC1/4	1	MSF
Drain pot	RC1/4	2	DP
Electronic dehumidifier		1	CL
Double solenoid pump	φ6 / φ4	2	PM
Bidirectional solenoid valve for calibration	RC1/4	1	SV5
Bidirectional anticorrosion solenoid valve	RC1/4	4	SV2, 3, 4, 6
Three-way anticorrosion solenoid valve	RC1/4	1	SV1
NO <sub>2</sub> /NO converter	φ9.5 / φ5.5	1	CV
Coupling	RC1/4	1	
Cheese pipe	φ6 / φ4	3	
Nipple	RC1/4	19	
Zero filter	φ6	(1)	
Through nipple	RC1/4	1	
Blank plug for H <sub>2</sub> O refilling	RC1/4	1	
Needle valve	φ6 / φ4	1	NV
Connection port	φ13 / φ9	1	
Elbow	φ6 / φ4	2	
Hose band	φ11	1	0

2. Note:  
The pipe length is a reference value.

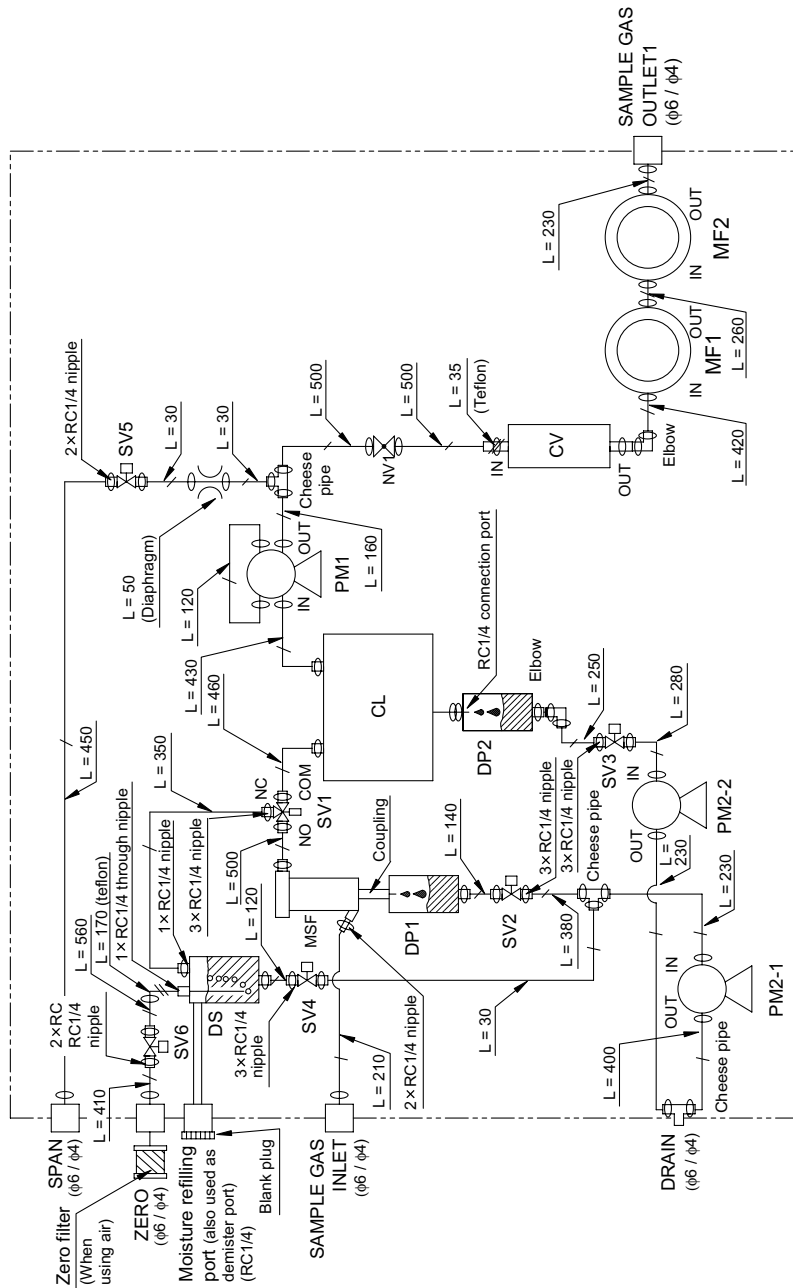



## 10.2.4 Outlet 2 system (2-component to 4-component meter including NO<sub>x</sub> meter)

### 1. Pipe material

Name	Pipe diameter	Quantity	Symbol
Toaron	φ9 / φ5	8380 mm	—
Teflon	φ6 / φ4	205 mm	—
Diaphragm	φ6 / φ1	50 mm	⊗
Hose band	φ8	62	0
Membrane filter	φ6 / φ4	2	MF1, 2
Demister	RC1/4	1	DS
Mist filter	RC1/4	1	MSF
Drain pot	RC1/4	2	DP
Electronic dehumidifier		1	CL
Double solenoid pump	φ6 / φ4	2	PM
Bidirectional solenoid valve for calibration	RC1/4	1	SV5
Bidirectional anticorrosion solenoid valve	RC1/4	4	SV2, 3, 4, 6
Three-way anticorrosion solenoid valve	RC1/4	1	SV1
NO <sub>2</sub> /NO converter	φ9.5 / φ5.5	1	CV
Coupling	RC1/4	1	
Cheese pipe	φ6 / φ4	4	
Nipple	RC1/4	19	
Zero filter	φ6	(1)	
Through nipple	RC1/4	1	
Blank plug for H <sub>2</sub> O refilling	RC1/4	1	
Needle valve	φ6 / φ4	2	NV
Connection port	φ13 / φ9	1	
Elbow	φ6 / φ4	2	
Hose band	φ11	1	

2. Note:  
The pipe length is a reference value.

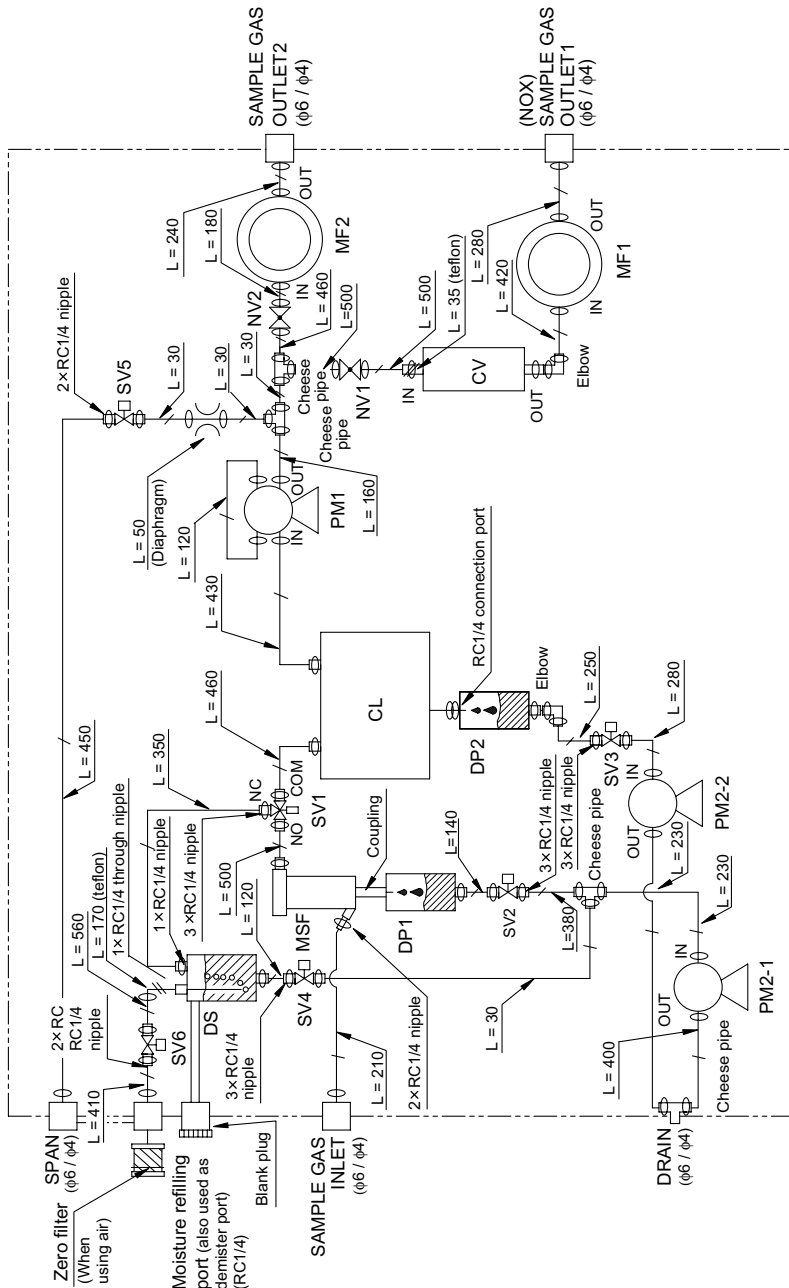

# 11. PRINTED CIRCUIT BOARD DIAGRAM

## 11.1 Amplifier printed circuit board at analyzer unit

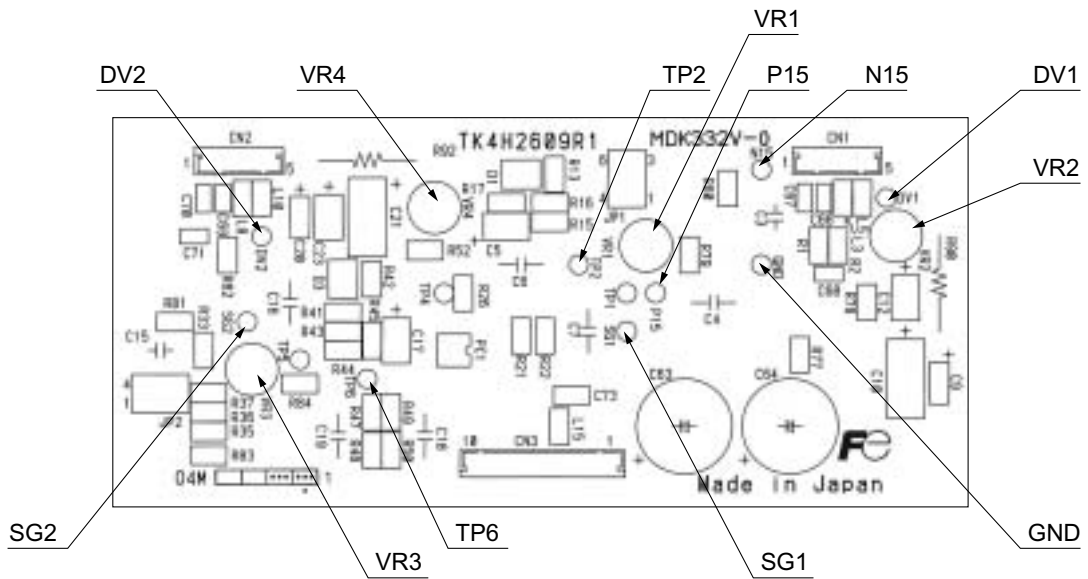

## 11.2 Control printed circuit board at analyzer unit

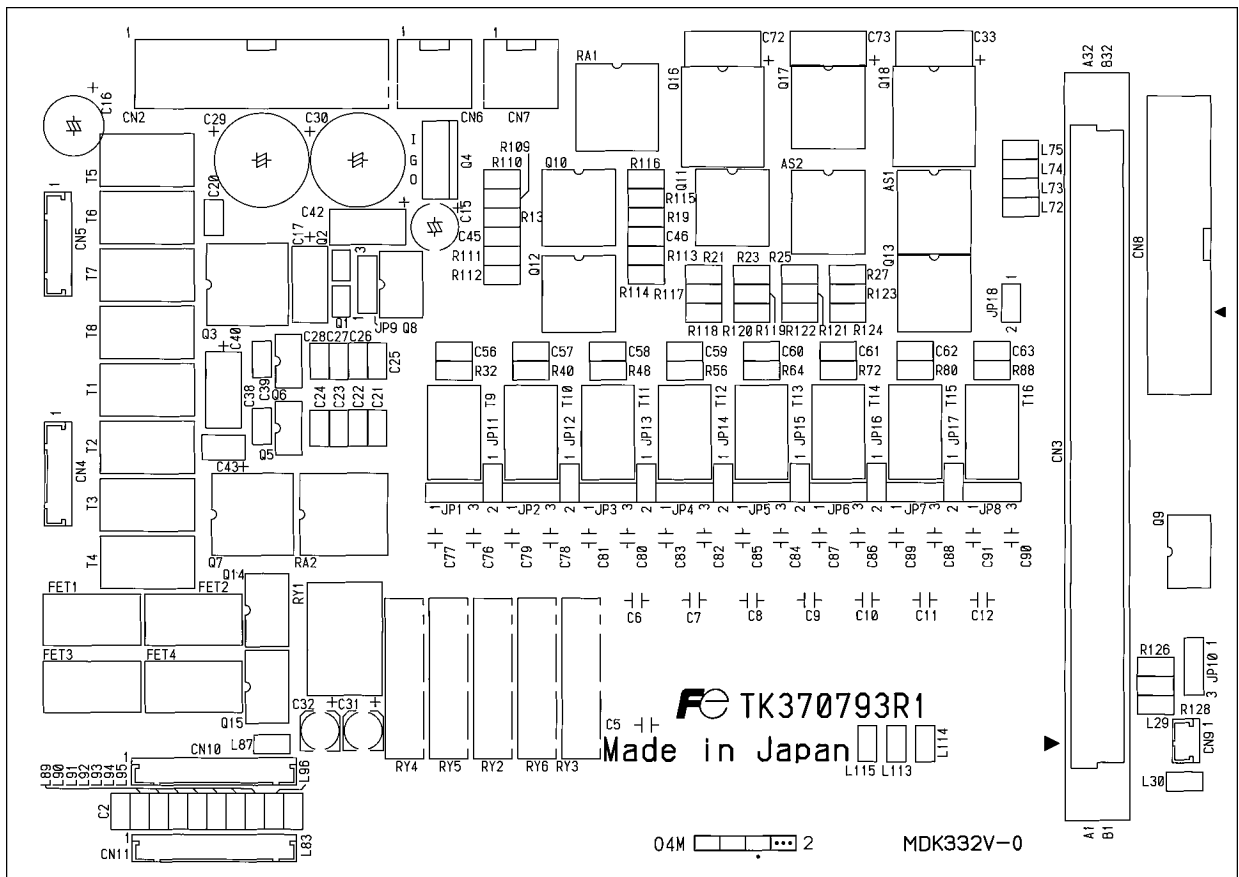

# 11.3 Main printed circuit board at analyzer unit

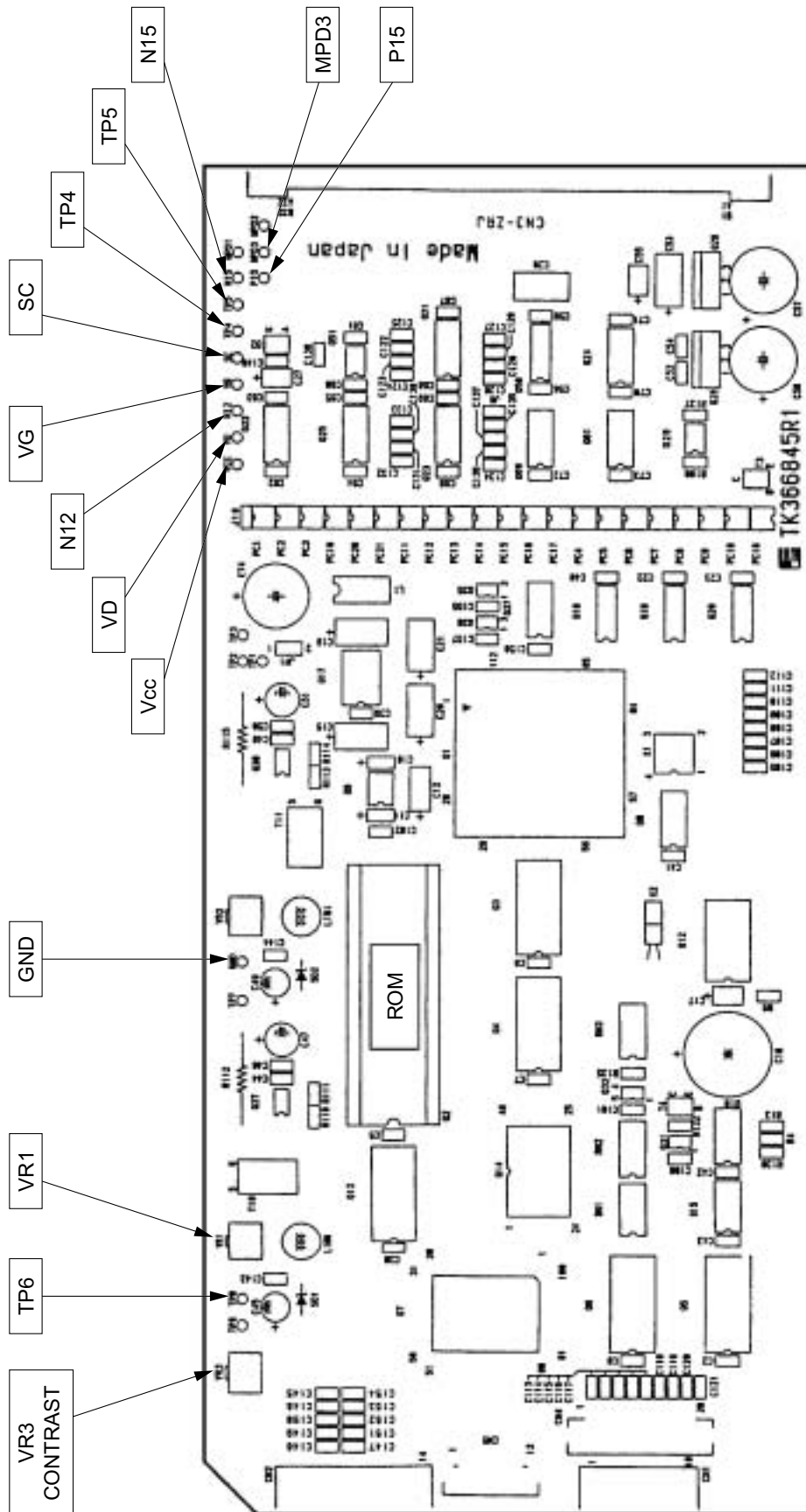

---

## **Fuji Electric Co., Ltd.**

### **International Sales Div**

#### **Sales Group**

Gate City Ohsaki, East Tower, 11-2, Osaki 1-chome,  
Shinagawa-ku, Tokyo 141-0032, Japan

<http://www.fujielectric.com>

Phone: 81-3-5435-7280, 7281 Fax: 81-3-5435-7425

<http://www.fujielectric.com/products/instruments/>

---