

ANALOG DIFFERENTIAL PRESSURE TRANSMITTER

DATA SHEET

FYC...K, L

The FYC analog pressure transmitter accurately measures differential pressure and transmits a proportional 4 to 20mA signal.

The transmitter utilizes an unique micromachined capacitive silicon sensor to provide exceptional performance and functionality.

FYC series are specifically designed for safety related applications encountered in nuclear power plants where high reliability and long lifetime under mild to harsh environment is required (radiation with total integrated dose (TID) 50 kGray).



FEATURES

1. High accuracy

Fuji's micro-capacitance silicon sensor assures a high accuracy for all elevated or suppressed calibration ranges without additional adjustment.

2. Minimum environmental influence

The "Advanced Floating Cell" design which, protects the pressure sensor against changes in temperature, static pressure, and overpressure substantially reduces total measurement error in actual field applications.

3. Application flexibility

Various features that render the FCX-All suitable for almost any process applications include.

- Hazardous area approvals
- Built-in RFI filter and lightning arrester
- Stainless steel electronics housing

4. Fully analog electronics

The design of the electronics without any SMART device embedded ensure the ability to address the highest safety levels in nuclear applications.

Functional specifications

Type :

FYC : Analog differential pressure transmitter

Service :

Liquid, gas or vapour

Static pressure, span and range limit :

Type	Static pressure [MPa] {bar}	Span limit [mmWC] {mbar}		Range limit [kPa] {mbar}
		Min.	Max.	
FYC□11	-0.1 to +3.2 {-1 to +32}	20 {2}	100 {10}	±1 {±10}
FYC□22	-0.1 to +10 {-1 to +100}	120 {12}	600 {60}	±6 {±60}
FYC□33	-0.1 to +16 {-1 to +160}	530 {53}	3200 {320}	±32 {±320}
FYC□35	-0.1 to +16 {-1 to +160}	2160 {216}	13000 {1300}	±130 {±1300}
FYC□36	-0.1 to +16 {-1 to +160}	8333 {833}	50000 {5000}	±500 {±5000}
FYC□38	-0.1 to +16 {-1 to +160}	50000 {5000}	300000 {30000}	±3000 {±30000}
FYC□43	-0.1 to +42 {-1 to +420}	530 {53}	3200 {320}	±32 {±320}
FYC□45	-0.1 to +42 {-1 to +420}	2160 {216}	13000 {1300}	±130 {±1300}
FYC□46	-0.1 to +42 {-1 to +420}	8333 {833}	50000 {5000}	±500 {±5000}
FYC□48	-0.1 to +30 {-1 to +300}	50000 {5000}	300000 {30000}	±3000 {±30000}

Lower limit of static pressure (vacuum limit) :

Silicon fill sensor : see fig.1 page 4

Over range limit :

To maximum static pressure limit

Output signal :

4 to 20mA DC (linear)

Power supply :

Transmitter operates on 13 to 48V DC at transmitter terminals.

Load limitations :

Mini (Ω) = 100 Ω
 Maxi (Ω) = 600 Ω

Hazardous locations :

Designed to meet international flameproof (explosionproof) standards.
 Please consult the code symbols some pages further on, to know the different types of approvals.
 Consult Fuji Electric for status.

Zero/span adjustment :

Zero is adjustable from outside screw on the electronics housing and the span with the internal screw.

Damping :

Possible damping : 0.1, 0.4, 1.2, 3.2 sec.

Zero elevation / suppression :

Adjustable with the external screw on the electronic housing between -90% to +84% of URL.

Temperature limit :

Ambient (with specified performance) :
 0 to 70°C
 Accident :
 Mini : -40°C
 Maxi : 125°C during 65 hours
 Process :
 -40 to +120°C (silicon oil)
 Storage :
 -40 to +90°C

Humidity limit :

0 to 100% RH (electronics housing closed and sealed)

Performance specifications

(Reference conditions, silicone oil fill).

Accuracy ratings :

(including linearity, hysteresis, and repeatability)

Max span above 32kPa models :

For spans greater than 1/6 of URL :
 $\pm 0.25\%$ of span

For spans below 1/6 of URL :

Fuji Electric doesn't guaranty the measurement accuracy.

Max span 1kPa, 6kPa models :

For spans greater than 1/5 of URL :
 $\pm 0.5\%$ of span

For spans below 1/5 of URL :

Fuji Electric doesn't guaranty the measurement accuracy.

Stability :

$\pm 0,2\%$ of upper range limit (URL) for 30 days.

Temperature effect :

Effects per 55°C change

Range (6th digit in code symbols)	Zero shift (% of URL)	Total effect (% of URL)
"1"	$\pm 2\%$	$\pm 4\%$
"2"		
"3"		
"5"	$\pm 1\%$	$\pm 2\%$
"6" and "8"		

Static pressure effect :

Static pressure code (5th digit in code symbols)	Zero shift (% of URL)	Span shift (% of URV)
"1"	$\pm 1\%$ / 10bar	-0,6% / 10bar
"2"	$\pm 0,2\%$ / 32bar	-0,6% / 32bar
"3"	$\pm 0,3\%$ / 100bar	-0,6% / 100bar
"4"		

Overrange effect :

Static pressure code (5th digit in code symbols)	Zero shift (% of URL)
"1"	$\pm 0,3\%$ / 10 bar
"2"	$\pm 0,1\%$ / 32 bar
"3"	$\pm 0,1\%$ / 160 bar
"4"	$\pm 0,25\%$ / 420 bar

Supply voltage effect :

$\pm 0,005\%/V$

RFI effect :

Less than 0,25% of URL for the frequencies of 80 to 2000MHz and field strength 10V/m when electronics covers on.

Response time : (at 63,2% of the output signal)

Range code (6th digit in code symbols)	Response time
"1"	800 msec
"2"	500 msec
"3"	300 msec
"5" to "8"	200 msec

Mounting position effect :

Zero shift :

Less than 12 mmH₂O for a 10° tilt in any plane.

No effect on span.

This error can be corrected by adjusting zero.

Vibration effect :

$< \pm 1.5\%$ of URL

Frequency 10 to 500Hz, acceleration 9,8m/sec²

Seismic resistance :

Qualification to the "assembly" seismic spectrum x 1.5 according to RCC-E :

- Horizontal 7.5g ZPA

- Vertical 6g ZPA

Integrity to the "components" seismic spectrum as per RCC-E : 30g ZPA

Dielectric strength :

500V AC, 50/60Hz during 1 min. between terminals + & - on the one hand, and transmitter body on the other hand.

Leak current less than 3mA.

Insulation resistance :

More than 100M Ω at 500V DC, during 1 min., between terminals + & - on the one hand, and transmitter body on the other hand.

Turn-on time :
4 seconds

Irradiation effect :
±2,5% of URL at total Integrated Dose (50 kGy)
Maximum Total Integrated Dose without permanent failure 65 kGy

Pressure equipment Directive (PED) 2014/68/UE
Digit 5 code 1, 2, 3 according to Article 4.3
Digit 5 code 4 : Category III module H1

Physical specifications

Electrical connections :
M20 x 1,5 or
Souriau 8N35 socket, or
Souriau 8N45S socket, or
Souriau 8N45 socket, or
SAIB NU25 ref. 251-103-401 / M20 x 1,5 socket
(Compatible with 8N45 installed base)

Process connections :
Standard : 1/4"-18 NPT
Option : 1/2"-14 NPT with oval flange

Process-wetted parts material :

Material code (7th digit)	Process cover	Diaphragm	wetted sensor body	Vent / Drain	
V	Ranges 1 & 2	SS 316	SS 316 L	SS 318LN (Duplex 1.4462)	SS 316
	Range 3 to 8	SS 316	SS 316 L	SS 316L	SS 316
A	Hast C276	Hast C276	Hast C276	Hast C276	Hast C276

Other material, upon request

Process gasket :
EPDM O-ring (mandatory when submitted to radiation with TID > 50 Gy) or Viton O-ring

Non-wetted parts material :
Electronics housing :
SS 316
Bolts and nuts :
SS 316 (static pressure ≤ 160 bar) or
SS 660 (static pressure > 160 bar)
Fill fluid :
Silicon oil
Mounting bracket :
SS 304

Environmental protection :
IP66/IP67

Mounting :
Without mounting bracket :
Direct mounting on manifold (optional)
With optional mounting bracket :
For 50mm (2") pipe or direct wall mounting

Mass {weight} :
Transmitter only : 7,4 kg
Add :
Mounting bracket : 0,5 kg

Optional features

Degreasing :
Process wetted parts are cleaned, but the fill fluid is standard silicone oil.

Optional customer tag plate (75 x 20 mm) :
A extra stainless steel tag with customer tag data is wired to the transmitter.

Vacuum service :
Special silicone oil and filling procedure are applied. (See below figure 1)

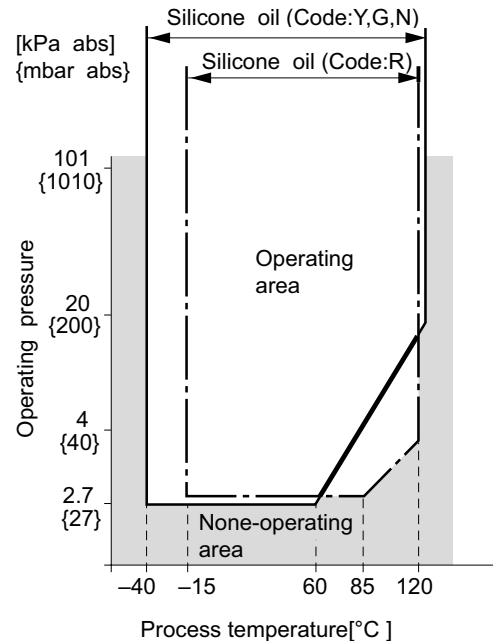

Fig.1 Relation between the temperature of process in contact with cell's diaphragms and operating pressure.

Optional accessories

Oval flanges :
Converts process connection to 1/2"-14 NPT

Manifolds :
Refer to datasheet No. EDS6-F03

CODE SYMBOLS - FYC

1	2	3	4	5	6	7	8	9	10	11	12	13	14	15	16	Description
F	Y	C						A							1	
																Analog differential pressure transmitter
																Connections
																Process
																Oval flange
																Conduit
W																M20 x 1,5 - ATEX cable gland for flameproof (optional)
3																Souriau 8N45S socket
6																Souriau 8N45 socket (not for EPR reactors)
7																Souriau 8N35 socket (not for EPR reactors)
8																SAIB NU25, ref 251-103-401 / M20 x 1,5 socket (compatible with 8N45 installed equipment)
																Range & materials
																Static pressure limits
																Spans
																Process cover LP & HP side
																Measuring diaphragm
																Wetted cell body
1	1	V														-1 to 32 bar
2	2	V														20 / 100 mmWC
3	3	V														530 / 3200 mmWC
3	5	V														2,16 / 13 mWC
3	6	V														8,333 / 50 mWC
3	8	V														50 / 300 mWC
4	3	V														530 / 3200 mmWC
4	5	V														2,16 / 13 mWC
4	6	V														8,333 / 50 mWC
4	8	V														50 / 300 mWC
1	1	A														-1 to 32 bar
2	2	A														20 / 100 mmWC
3	3	A														530 / 3200 mmWC
3	5	A														2,16 / 13 mWC
3	6	A														8,333 / 50 mWC
3	8	A														50 / 300 mWC
4	3	A														530 / 3200 mmWC
4	5	A														2,16 / 13 mWC
4	6	A														8,333 / 50 mWC
4	8	A														50 / 300 mWC
																Transmitter version
																EDF "K3ad classification"
																EDF "Not Classified"
																Approvals for hazardous locations (consult Fuji)
																None (standard)
																Flameproof housing ATEX II 2 GD - Ex d IIC T5/T6
																Vent / drain & mounting bracket
																Vent / drain
																Mounting bracket (SS 304)
																Universal, direct mounting
																None
																Universal, direct mounting
																Yes - Recommended for UTO stock
																Optional customer tag plate & Electronics housing
																Tag plate
																Electronics housing
																Without
																SS 316
																SS 316L
																SS 316
																Special applications & Fill fluids
																Treatment
																Fill fluids
																None
																Silicon oil
																Degreasing
																Silicon oil
																Vacuum service
																Silicon oil
																Process cover gasket
																Viton
																EPDM
																Bolts and nuts material
																SS 316/316 (Bolts/nuts) - M10
																SS 660/660 (Bolts/nuts) - M12
																Accessories (optional)
																ATEX - Flameproof cable gland

*Notes :

- All models are equipped with surge arrester specifically designed for EDF.
- 1- The thread of process cover is M12, if static pressure of 420 bar (5th digit = 4)
- 2- SS316 M10 bolting (15th digit = E) is only for use with models whose maximum working pressure is up to 160 bar ; For static pressure > 160 bar, please specify : SS 660 bolts in M12 (15th digit = W); Bolting for process covers of transmitters Classified K3A has a corrosion protective treatment on all non machined surfaces.
- 3- Not available for SAIB, Souriau 8N35 / 8N45 / 8N45S sockets. To use with flameproof cable gland ATEX delivered by FUJI (option) or mounted by EDF.
- 4- Transmitters' design is similar to K3A but on standard QA (ISO 9001)
- 5- For "K3A classification" transmitter, please contact Fuji Electric france
- 6- FYC6 & FYC7 transmitters can only be used in existing power plants (not for EPR)
- 7- FYCW, FYC3 & FYC8 transmitters can be used in existing power plants and EPR. FYCW transmitters can be equipped with (optional) Flameproof cable gland. When mounted on the transmitter, additional 16th digit is set to 1.
- 8- For others materials, please contact Fuji Electric france

OUTLINE DIAGRAM (unit : mm)

Conduit connection M20 x 1,5 (4th digit = W)

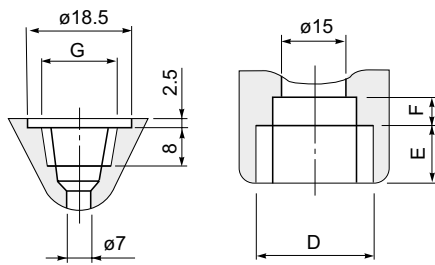
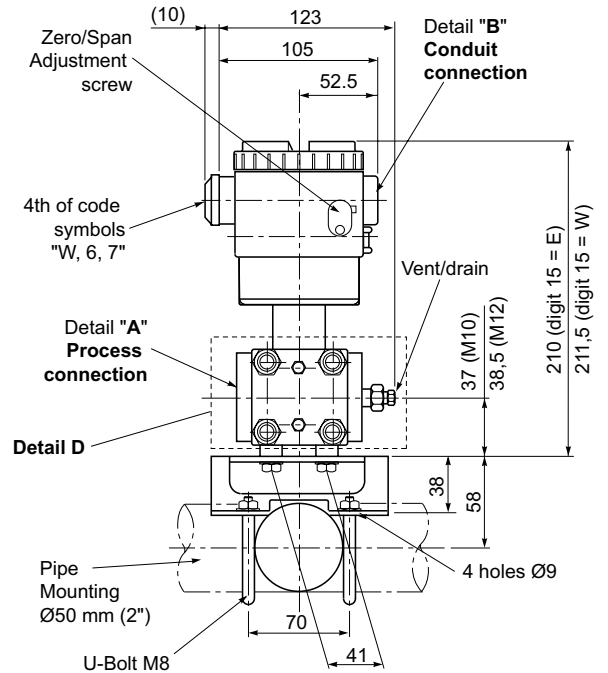
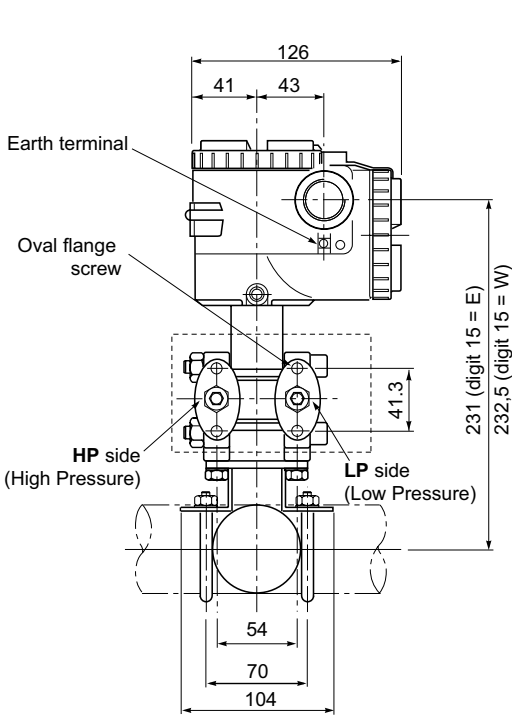

Detail "A" Process connection Detail "B" Conduit connection

4th digit	Conduit connection			Process connection
	D	E	F	G
W	M20 X 1,5	16	5	1/4-18NPT

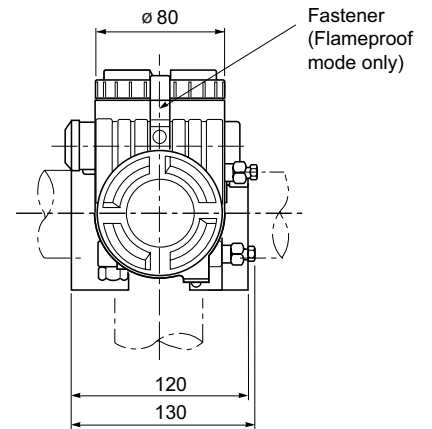

"Universal vent/drain, direct mounting" configuration (11th digit : G & H) (recommended for UTO stock)

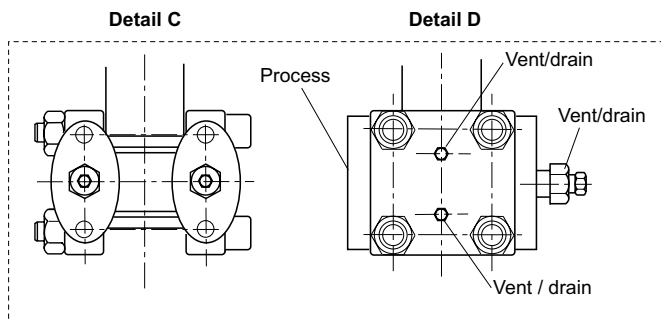

With this configuration, vent/drain function on the **external side** of the process flanges is achieved by way of vent screws directly attached to the flange (sealing is of metal to metal type). There is no more conventional screwed vent seat screwed in the flange and sealed with "PMUC Loctite" type compound.

OUTLINE DIAGRAM (unit : mm)

Conduit connection for SOURIAU sockets (4th digit = code 3, 6 or 7)

For Souriau 8N35 socket

CONDUIT CONNECTION - SOURIAU 8N35

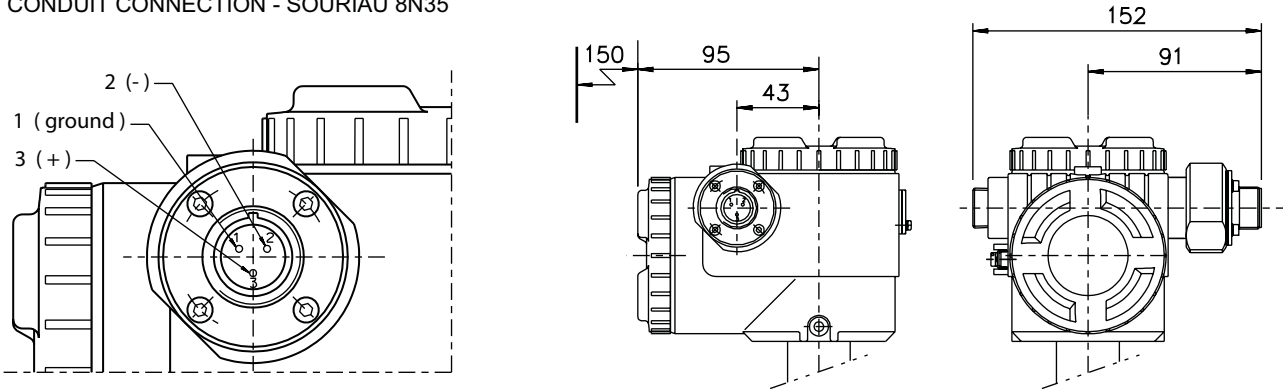

For Souriau 8N45 / 8N45S sockets

Conduit connection - SOURIAU 8N45 / 8N45S

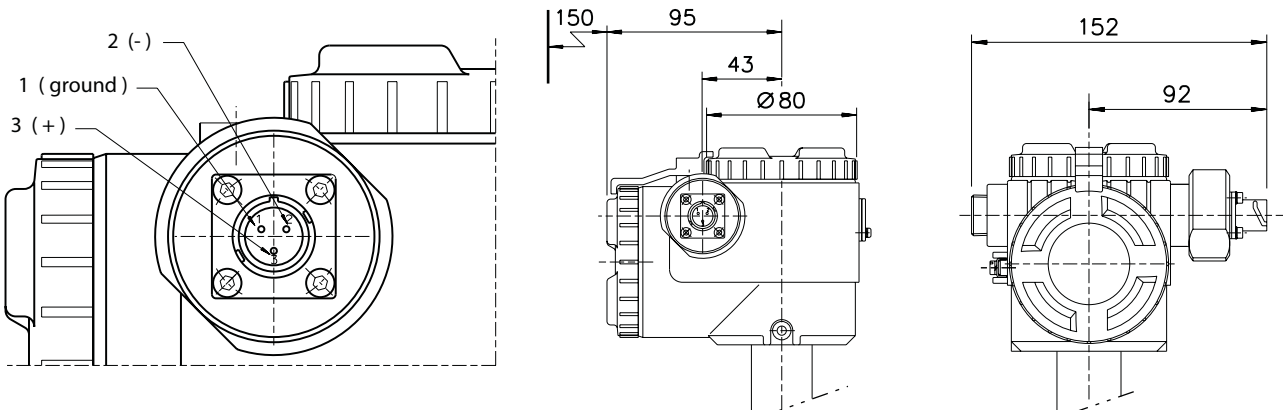

Conduit connection SAIB socket (4th digit = code 8)

CONDUIT CONNECTION- SAIB socket

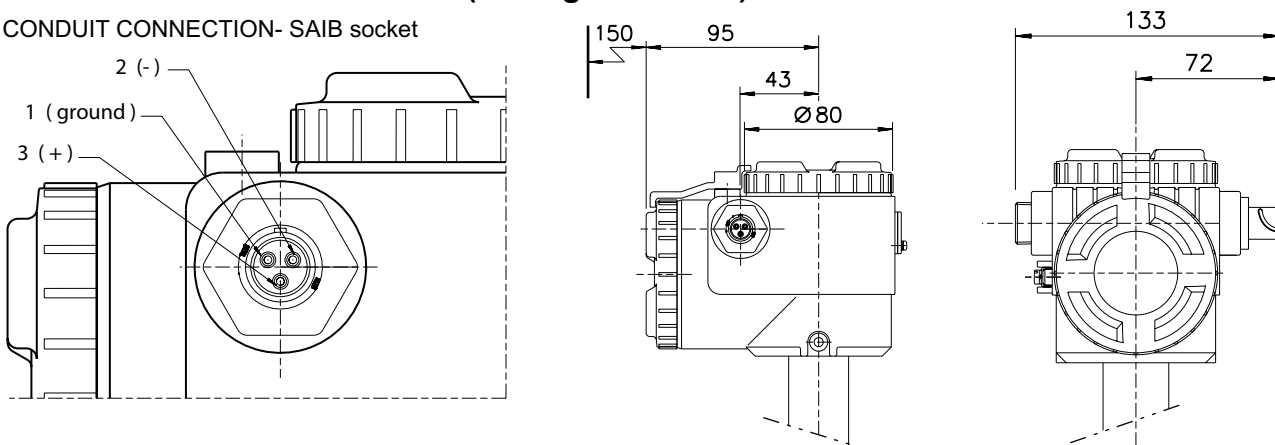

CONNECTION DIAGRAM

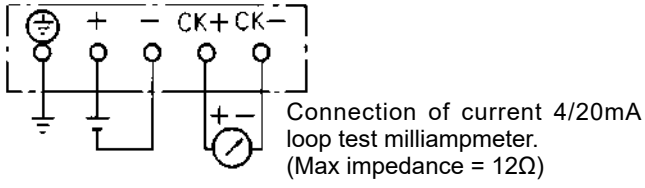

OPTIONAL CUSTOMER TAG PLATE

Attached to transmitter with SS 304 wire

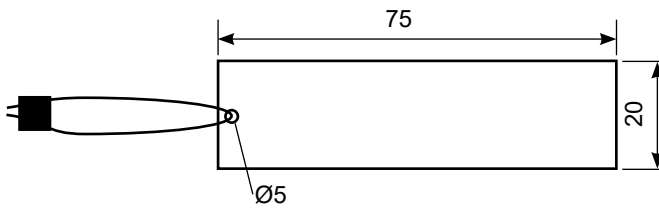

ELECTROMAGNETIC COMPATIBILITY

All FCX-All series of pressure transmitters are in conformity with the provision of the EMC Directive 2014/30/EU on the harmonization of the laws of the Members States relating to electromagnetic compatibility.

All these models of pressure transmitters are in accordance with the following harmonized standards :

- **EN 61326-1** (*Electrical equipment for measurement, control and laboratory use - EMC requirements - Part 1: General requirements*).
- **EN 61326-2-3** (*Particular requirements - Test configuration, operational conditions and performance criteria for transducers with integrated or remote signal conditioning*).

Emission limits (according to EN 55011 / CISPR 11, Group 1 Class A)

Frequency range (MHz)	Limits	Result
30 to 230	40 dB ($\mu\text{V/m}$) quasi peak, measured at 10 m distance	Passed
230 to 1000	47 dB ($\mu\text{V/m}$) quasi peak, measured at 10 m distance	

Immunity

Phenomenon	Test value	Standard	Required Performance criteria	Result of criteria
Electrostatic Discharge	± 4 kV (Contact) ± 8 kV (Air)	EN/IEC 61000-4-2	B	A
Radiated, Electromagnetic Field	10 V/m (0.08 to 1.0 GHz) 3 V/m (1.4 to 2.0 GHz) 1 V/m (2.0 to 2.7 GHz)	EN/IEC 61000-4-3	A	A
Fast transients (burst)	2 kV (5/50 ns, 5 kHz)	EN/IEC 61000-4-4	B	A
Surge Transients	1 kV Line to line 2 kV Line to ground	EN/IEC 61000-4-5	B	A
Conducted RF Disturbances	3 Vrms (150 kHz to 80 MHz) 80% AM @ 1 kHz	EN/IEC 61000-4-6	A	A
Power Frequency Magnetic Field	30 A/m (50 Hz, 60 Hz)	EN/IEC 61000-4-8	A	A

Performance criteria (A & B): according to IEC 61326

**Fuji Electric France S.A.S.**

46 rue Georges Besse - ZI du brézet - 63039 Clermont ferrand

Tél : 04 73 98 26 98 - Fax : 04 73 98 26 99

Mail : sales.dpt@fujielectric.fr - web : www.fujielectric.fr

Fuji Electric can accept no responsibility for possible errors in catalogues, brochures and other printed material. Fuji Electric reserves the right to alter its products without notice. This also applies to products already on order provided that such alterations can be made without subsequent changes being necessary in specifications already agreed. All trademarks in this material are property of the respective companies. All rights reserved.