

ANALOG ABSOLUTE PRESSURE TRANSMITTER

DATA SHEET

FYA...K, L

The FYA pressure transmitter accurately measures absolute pressure and transmits a proportional 4 to 20mA signal.

The transmitter utilizes an unique micromachined capacitive silicon sensor to provide exceptional performance and functionality.

FYA series are specially designed for safety related applications encountered in nuclear power plants where high reliability and long lifetime under mild to harsh environment is required (radiation with total integrated dose 50 kGray).



FEATURES

1. High accuracy

Fuji's micro-capacitance silicon sensor assures a high accuracy for all elevated or suppressed calibration ranges without additional adjustment.

2. Minimum environmental influence

The "Advanced Floating Cell" design which, protects the pressure sensor against changes in temperature, static pressure, and overpressure substantially reduces total measurement error in actual field applications.

3. Application flexibility

Various features that render the FCX-All suitable for almost any process applications include.

- Hazardous area approvals
- Built-in RFI filter and lightning arrester
- Stainless steel electronics housing

4. Fully analog electronics

The design of the electronics without any SMART device embedded ensure the ability to address the highest safety levels in nuclear applications.

Functional specifications

Type :

FYA : Analog absolute pressure transmitter

Service :

Liquid, gas or vapour

Span, range and overrange limit :

Model	Span limits kPa abs {bar abs}		Range limits kPa abs {bar abs}	Overrange limit MPa {bar}
	Min.	Max.		
FYA□01	2.7 {0.027}	16 {0.16}	0 to +16 {0 to +0.16}	0.5 {5}
FYA□02	21.7 {0.217}	130 {1.3}	0 to +130 {0 to +1.3}	0.5 {5}
FYA□03	83.4 {0.834}	500 {5}	0 to +500 {0 to +5}	1.5 {15}
FYA□04	500 {5}	3000 {30}	0 to +3000 {0 to +30}	9 {90}

Output signal :

4 to 20 mA

Power supply :

Transmitter operates on 13 to 48V DC at transmitter terminals

Load limitations :

Mini = 100Ω
Maxi = 600Ω

Hazardous locations :

Designed to meet international flameproof (explosionproof) standards.
Please consult the code symbols some pages further on, to know the different types of approvals (digit 10).
Consult FUJI for status.

Zero/span adjustment :

Zero is adjustable from outside screw on the electronics housing and the span with the internal screw.

Damping :

Possible damping : 0.1, 0.4, 1.2, 3.2 sec.

Zero elevation / suppression :

Adjustable with the external screw on the electronic housing between 0 kPa abs. to +84% of URL.

Temperature limit :

Ambient :
0 to 70°C
Accident :
Mini : -40°C
Maxi : 125°C during 65 hours
Process :
-40 to +85°C (silicone oil)
Storage :
-40 to +90°C

Humidity limit :

0 to 100% RH (electronics housing closed and sealed)

Performance specifications

(reference conditions, silicone oil fill).

Accuracy ratings

(including linearity, hysteresis, and repeatability)

For all ranges :

For spans greater than 1/6 of URL :
±0.5% of span

For spans below 1/6 of URL :

Fuji Electric doesn't guaranty the measurement accuracy.

Stability :

± 0.4 % of upper range limit (URL) for 30 days.

Temperature effect :

Effects per 55°C change

For all ranges :

Zero shift :
±2% of URL
Span shift :
±2% of URL
Total effect :
±4% of URL

Overrange effect :

Zero shift :
0.2% of URL for any overrange up to maximum limit

Supply voltage effect :

± 0,005%/V

RFI effect :

Less than 0,25% of URL for the frequencies of 80 to 2000 MHz and field strength 10V/m when electronics covers on.

Response time : (at 63,2% of the output signal)

200 msec.

Mounting position effect :

Zero shift :
Less than 0.1kPa {1mbar} for a 10° tilt in any plane.
No effect on span.
This error can be corrected by adjusting Zero.

Vibration effect :

< ±0,25% of span for spans greater than 1/10 of URL.
Frequency 10 to 500Hz, acceleration 9,8m/sec²

Seismic resistance

Qualification to the "assembly" seismic spectrum x 1.5 according to RCC-E :
- Horizontal 7.5g ZPA
- Vertical 6g ZPA.
Integrity to the "components" seismic spectrum as per RCC-E : 30 g ZPA

Dielectric strength :

500V AC, 50/60Hz during 1min. between terminals + & - on the one hand, and transmitter body on the other hand.
Leak current less than 3 mA.

Insulation resistance :

More than 100MΩ at 500V DC during 1min. between terminals + & - on the one hand, and transmitter body on the other hand.

Turn-on time :

4 seconds

Irradiation effect :

±2,5% of URL at Total Integrated Dose (50 kGy)
Maximum Total Integrated Dose without permanent failure 65 kGy.

Pressure equipment Directive (PED) 2014/68/UE

Digit 5 code 1, 2, 3 according to Article 4.3
Digit 5 code 4 : Category III module H1

Physical specifications

Electrical connections :

M20 x 1,5 or
Souriau 8N35 socket, or
Souriau 8N45S socket, or
Souriau 8N45 socket, or
SAIB NU25 ref. 251-103-401 / M20 x 1,5 socket
(Compatible with 8N45 installed base)

Process connections :

Standard :
1/4 - 18 NPT
Option :
1/2 - 14 NPT with oval flange

Process-wetted parts material :

Material code (7th digit)	Process cover	Diaphragm	Wetted sensor body	Vent/ Drain
V	SS 316	SS 316 L	SS 316L	SS 316
J	SS 316	SS 316 L + Gold coat	SS 316L	SS 316
A	Hast.C 276	Hast.C 276	Hast.C 276	Hast.C 276

Other material, upon request

Process gasket :

EPDM O-ring (mandatory when submitted to radiation with TTD > 50 Gy) or Viton O-ring

Non-wetted parts material :

Electronics housing :
SS 316
Bolts and nuts :
SS 316
Fill fluid :
Silicon oil
Mounting bracket :
SS 304.

Environmental protection :

IP66/IP67

Mounting :

Without mounting bracket :
Direct mounting on manifold
With optional mounting bracket :
For 50 mm (2") pipe or direct wall mounting.

Mass {weight} :

Transmitter only : 5.7 kg
Add :
Mounting bracket : 0,5 kg

Optional features

Degreasing :

Process wetted parts are cleaned, but the fill fluid is standard silicone oil.

Customer tag plate (70 x 20 mm) :

A stainless steel tag with customer tag data is wired to the transmitter.

Optional accessories

Oval flanges :

Converts process connection to 1/2 - 14 NPT

Manifolds :

Refer to datasheet No. EDS6-F03

OUTLINE DIAGRAM (unit : mm)

Conduit connection for SOURIAU sockets (4th digit = code 3, 6 or 7)

For Souriau 8N35 socket

CONDUIT CONNECTION - SOURIAU 8N35

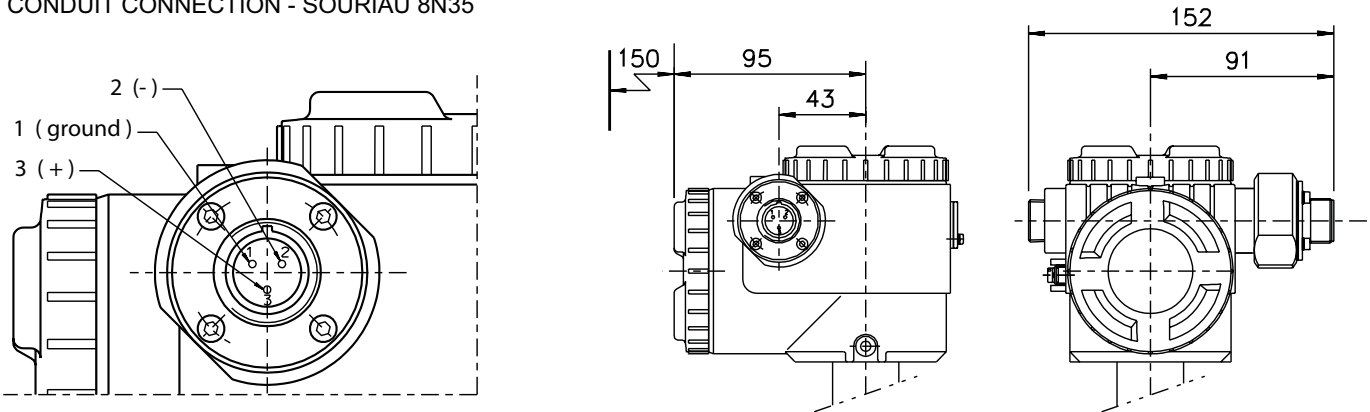

For Souriau 8N45 / 8N45S sockets

Conduit connection - SOURIAU 8N45 / 8N45S

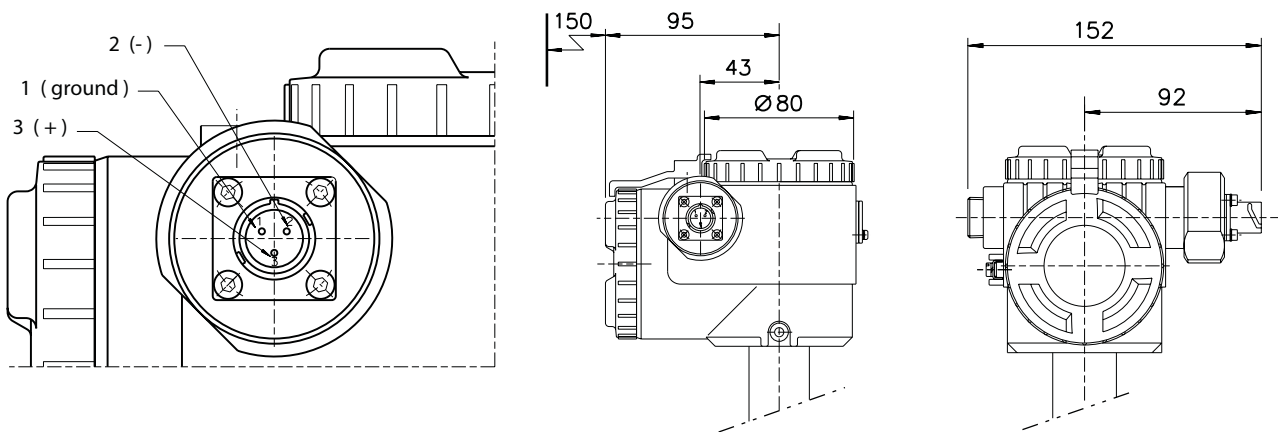

Conduit connection for SAIB socket (4th digit = code 8)

CONDUIT CONNECTION- SAIB socket

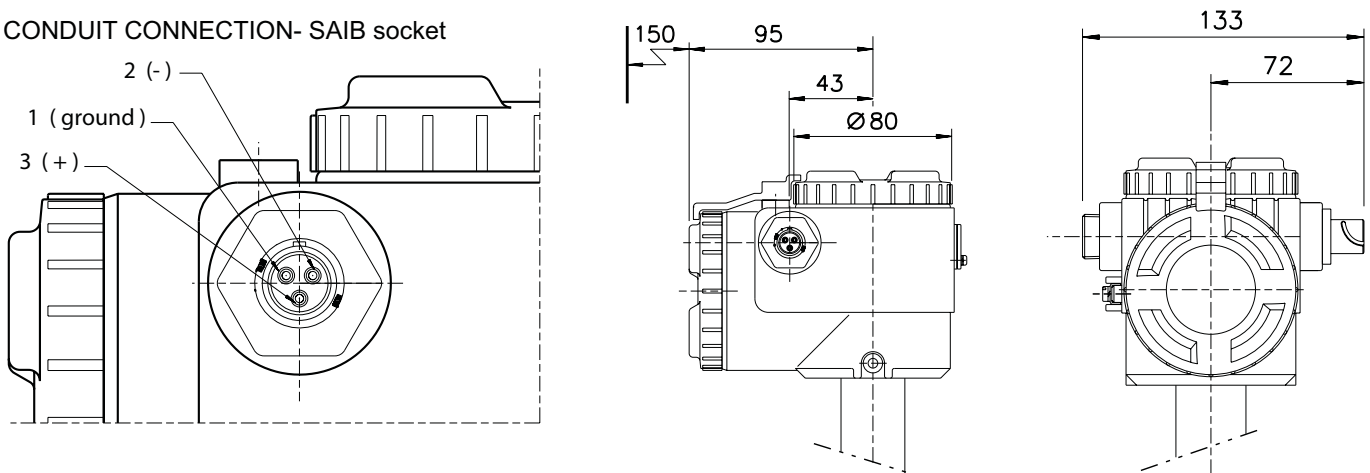

CONNECTION DIAGRAM

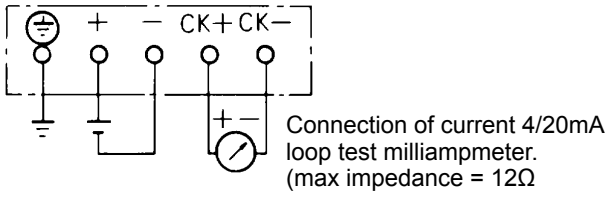

OPTIONAL CUSTOMER TAG PLATE

Attached to transmitter with SS 304 wire

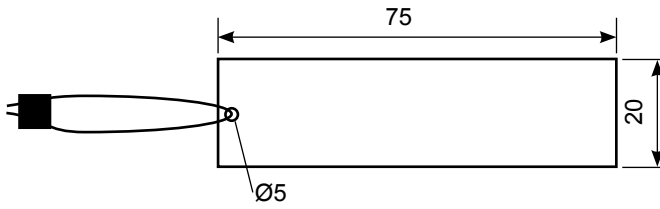

ELECTROMAGNETIC COMPATIBILITY

All FCX-All series of pressure transmitters are in conformity with the provision of the EMC Directive 2014/30/EU on the harmonization of the laws of the Members States relating to electromagnetic compatibility.

All these models of pressure transmitters are in accordance with the following harmonized standards :

- **EN 61326-1** (*Electrical equipment for measurement, control and laboratory use - EMC requirements - Part 1: General requirements*).
- **EN 61326-2-3** (*Particular requirements - Test configuration, operational conditions and performance criteria for transducers with integrated or remote signal conditioning*).

Emission limits (according to EN 55011 / CISPR 11, Group 1 Class A)

Frequency range (MHz)	Limits	Result
30 to 230	40 dB (μ V/m) quasi peak, measured at 10 m distance	Passed
230 to 1000	47 dB (μ V/m) quasi peak, measured at 10 m distance	

Immunity

Phenomenon	Test value	Standard	Required Performance criteria	Result of criteria
Electrostatic Discharge	± 4 kV (Contact) ± 8 kV (Air)	EN/IEC 61000-4-2	B	A
Radiated, Electromagnetic Field	10 V/m (0.08 to 1.0 GHz) 3 V/m (1.4 to 2.0 GHz) 1 V/m (2.0 to 2.7 GHz)	EN/IEC 61000-4-3	A	A
Fast transients (burst)	2 kV (5/50 ns, 5 kHz)	EN/IEC 61000-4-4	B	A
Surge Transients	1 kV Line to line 2 kV Line to ground	EN/IEC 61000-4-5	B	A
Conducted RF Disturbances	3 Vrms (150 kHz to 80 MHz) 80% AM @ 1 kHz	EN/IEC 61000-4-6	A	A
Power Frequency Magnetic Field	30 A/m (50 Hz, 60 Hz)	EN/IEC 61000-4-8	A	A

Performance criteria (A & B): according to IEC 61326

**Fuji Electric France S.A.S.**

46 rue Georges Besse - ZI du brézet - 63039 Clermont ferrand

Tél : 04 73 98 26 98 - Fax : 04 73 98 26 99

Mail : sales.dpt@fujielectric.fr - web : www.fujielectric.fr