

# THERMAL CONDUCTIVITY GAS ANALYZER <FOR HAZARDOUS LOCATION>

DATA SHEET

ZAFE

Thermal conductivity gas analyzer is a gas analyzer which quantitatively measures gas concentration by utilizing a causal relationship that the temperature of a heated platinum wire changes with gas concentration. The analyzer continuously measures the concentration of gases such as H<sub>2</sub>, He, and Ar with high stability.

## FEATURES

1. Easy-to-see large LCD is helpful for efficient operation.
2. Measured value is output as a linearized output signal.
3. Line voltage lies within 100 V to 240 V AC, 50/60 Hz.
4. Zero point and span can be automatically calibrated (at option).
5. Other gases' interference is correctable (at option).
6. Communicable with other system through an RS-232C interface (MODBUS™) (at option).

## SPECIFICATIONS

### Standard Specifications

#### Measuring principle:

Measurement of thermal conductivity

#### Measurable component:

He, Ar, H<sub>2</sub>, CH<sub>4</sub>, CO<sub>2</sub>

#### Measurable range: Refer to Table 1

Output signal: 4 to 20 mA DC, 0 to 1 V DC, 0 to 10 mV DC

Isolated output

(Any one-output signal specifiable in CODE SYMBOLS)

#### Allowable load resistance:

550 Ω max. (in 4 to 20 mA DC output)

#### Output resistance:

100 kΩ (in 0 to 1 V DC or 0 to 10 mV DC output)

Display unit: LCD with backlight

#### Display of measured value:

Max. 4 digits

Display language: English

#### Output signal holding:

In both manual and automatic calibrations, output value just before calibration can be held

Power supply: 100 to 240 V AC, 50/60 Hz

#### Power consumption:

Approx. 50 VA

Warm-up time: At least 30 min



#### Ambient temperature:

-5 to 45°C

Ambient humidity: Less than 90% RH (condensation unallowable)

#### Storage conditions:

-20 to 60°C, less than 95% RH (condensation unallowable)

Mounting: Mounted flush on panel

#### External dimensions (H x W x D):

470 x 354 x 211 mm

Mass: Approx. 22 kg

Finish color: Case: Silver  
Cover: Blue

Housing: Aluminum case/cover (IP65)

#### Material of gas-contacting parts:

JIS SUS304, platinum, platinum iridium, silver, fluororubber, epoxy resin, nickel, tin

#### Gas inlet/outlet, purge port:

Rc1/2 or NPT1/2 or G1/2 (whichever specified)

#### External connection terminal:

M3.5 screw terminal (9-pin D-sub connector for RS-232C)

Ex. Standard: NEPSI (Exd IIc T6Gb)

**Performance**

**Repeatability:** ±1% of F.S.  
**Linearity:** ±2% of F.S.  
**Drift:** Zero point : within ± 2% of full scale/ week (H<sub>2</sub> meter, reference gas N<sub>2</sub>)  
 Span : within ± 2% of full scale/week (H<sub>2</sub> meter, reference gas N<sub>2</sub>)  
**Response time (90% response):**  
 High speed within 10 sec (at flow rate 1L/min), allowed only for H<sub>2</sub> meter (reference gas N<sub>2</sub>, without interference compensation)  
 Standard within 60 sec (at flow rate 0.4 L/min)

**Other gases interference:**

Indication error of each measured value (vol%)

Interference component	H <sub>2</sub> meter	H <sub>4</sub> meter	Ar meter	CO <sub>2</sub> meter
H <sub>2</sub> 1%	-	+5.8	-6.5	-8.0
CH <sub>4</sub> 1%	+0.17	-	-1.15	-1.38
SO <sub>2</sub> 1%	-0.31	-1.8	+2.1	+2.5
Ar 1%	-0.15	-0.87	-	+1.2
CO <sub>2</sub> 1%	-0.125	-0.725	+0.83	-
O <sub>2</sub> 1%	+0.019	+0.11	-0.125	-0.15
H <sub>2</sub> O 1.5°C saturation	-	-	-	-0.56

**Standard Gas Measurement Conditions**

**Temperature:** 0 to 50 °C  
**Gas flow rate:** Constant at 0.4 ± 0.05 L/min  
 Constant at 1 ± 0.05 L/min(High response)  
**Dust:** Less than 100 µg/Nm<sup>3</sup> with a particle size of 0.3 µm max  
**Pressure:** 10 kPa max  
**Mist:** Unallowable  
**Oxygen gas:** No oxygen should be contained in measured combustible gases.  
**Moisture:** Below saturation at 2 °C  
**Corrosive gas:** Unallowable  
**Standard gases for calibration:**

Zero gas: same as reference gas or as specified  
 Span gas: Concentration within 90 to 100% of measuring range (Positive range)  
 Concentration beyond 100% is inapplicable

**Installation Conditions**

- The analyzer should not be exposed to direct sunlight or radiation from a hot object.
- A place subjected to heavy vibrations should be avoided. A location with clean atmosphere should be selected.
- When the analyzer is installed outdoors, it should be sheltered with a housing or cover to protect it from rain and wind.

**Optional Specifications**

**Relay contact output:**

5 SPST relay contact outputs  
 Relay contact capacity; 220 V AC/2 A (resistive load)  
 Isolated with relay between contacts, and between contacts and internal circuit.  
 Max. 5 points are selectable among those listed below.  
 <1> Zero-side solenoid valve drive output for automatic calibration  
 <2> Span-side solenoid valve drive output for automatic calibration  
 <3> Suction pump OFF output in automatic calibration (reray "ON" immediately after turning on power supply)  
 <4> Upper limit (1 point) concentration alarm output  
 <5> Lower limit (1 point) concentration alarm output  
 <6> Upper/Lower limit (1 point) concentration alarm output  
 <7> Upper limit (1 point) and lower limit (1 point) concentration alarm output (Total 2 points)  
 <8> High-high limit (1 point at each step) concentration alarm output (Total 2 points)  
 <9> Low-low limit (1 point at each step) concentration alarm output (Total 2 points)  
 <10> Analyzer error or automatic calibration error alarm output  
 <11> Calibrating status output  
 <12> Range information output (only with 2-range meter)

**Contact input:**

3 non-voltage contact inputs  
 ON; 0 V, OFF; 5 V DC, current at ON; 5 mA  
 Isolated with photo coupler between inputs and internal circuit. Not is lated between contact inputs.  
 The following actions can be input  
 <1> Remote holding of measured value output  
 <2> Remote range changeover (only with 2-range meter)  
 <3> Remote start of automatic calibration

**Interference gas measured value input:**

Analog input for H<sub>2</sub> meter interference correction (1 to 5 V DC, 1 range)  
 Either CO<sub>2</sub> or CH<sub>4</sub> component of an external gas analyzer is to be input. Adjustment is required at Fuji Electric's factory.  
 Details of measurement gas will be checked when receiving an order.

### Automatic calibration function:

Zero and span calibrations are automatically carried out at the predetermined intervals.  
Calibration gases are flowed sequentially by driving the externally installed solenoid valves.

### Communicating function

RS-232C (9-pin D-sub output)  
Half duplex, asynchronous  
MODBUS™ protocol, communication speed 9600 bps

Contents of communication:

Reading/writing of measured concentration values and various set values, and output of device status

Remarks: For connection in RS-485, RS-232C/RS-485 converter should be provided separately

### Performance

Output signal holding	When holding is set (user setting is turned ON), the latest measured value output just before output signal holding will be held during manual or automatic calibration, or by remote output holding input. In this status, indicated values will not be held.
Remote output holding input	Upon short-circuiting the remote output holding input terminal when holding is set (user setting is turned ON), the latest measured value output will be held. Holding continues while the contact input terminal is close-circuited. In this period, indicated values will not be held.
Remote range changeover input	When remote range setting is selected (user setting is turned ON) for two rang type, range will be changed over according to the external signal input (non-voltage contact) applied to the remote range changeover input terminal. In this mode, range cannot be changed manually. When close-circuiting the contact input terminal, the first range is selected, and the second range is selected at open circuit.
Range identification signal output	With two rang type, the current measuring range identification is output in contact signal. The contact output terminal is closed for the first range, and open for the second range.
Automatic calibration	Zero and span calibrations are automatically carried out by outputting the signal for driving the externally installed solenoid valves for calibration gases at the set start time and interval or through input of the remote calibration start signal. <ul style="list-style-type: none"> <li>• Calibration channel: 1 component</li> <li>• Calibration accuracy: 0.2% of F.S.</li> <li>• Zero calibration point settable range: 0 to 100% of F.S.</li> <li>• Span calibration point settable range: 1 to 100% of F.S.</li> <li>• Calibration interval settable range: 1 to 99 hours (1 hour step) or 1 to 40 days (1 day step)</li> <li>• Calibration gas injection time settable range: 60 to 599 sec (in sec)</li> <li>• Calibration start: Internal timer or remote calibration start input</li> <li>• Solenoid valve drive signal output: SPST contact (zero x 1, span x 1)</li> <li>• Suction pump OFF output in calibration: SPST contact (suction pump OFF x 1)</li> <li>• Remote calibration start input: No-voltage contact input</li> </ul> <p>Automatic calibration is started by applying a non-voltage rectangular wave to the remote calibration start input terminal (opened after close-circuiting for 1.5 sec or longer). When contacts open, automatic calibration is carried out once.</p> <ul style="list-style-type: none"> <li>• Automatic calibration error alarm output: SPST contact Contacts close when the quantity of zero or span calibration exceeds 50% of full scale from the level of previous calibration, and contacts open when there is no abnormalities. When automatic calibration is abnormal, measurement output depends on the previous calibration values.</li> <li>• Automatic calibration status output: SPST contact During automatic calibration, contacts close, and open when within 50%.</li> </ul>
Upper/lower limit, upper limit and lower limit alarm output	Alarm contact output is issued with reference to the set upper/lower limit for alarm. Hysteresis is settable. When measuring value exceed alarm setting value, contacts close, and open when not exceeded. SPST contact
Analyzer error	When the analyzer or automatic calibration is abnormal, contacts close, and open when normal. SPST contact
Interference correction by interference gas measured value input	Correction is made using either CO <sub>2</sub> or CH <sub>4</sub> component for H <sub>2</sub> measurement. Measured H <sub>2</sub> gas concentration is corrected in response to a concentration change of interference gas within its concentration range measured and set in advance. External interference gas measured value input : 1 to 5 V DC, 1range Interference gas fluctuation range : Reference concentration 20% F.S. H <sub>2</sub> gas concentration correcting range : Reference concentration 25% F.S. Correction accuracy : 5% F.S. (Note 1) Enter in the sample gas component check list on the back cover. (Note 2) Correction accuracy value is larger when other interference gas is contained in the sample gas.

## MEASURING PRINCIPLE

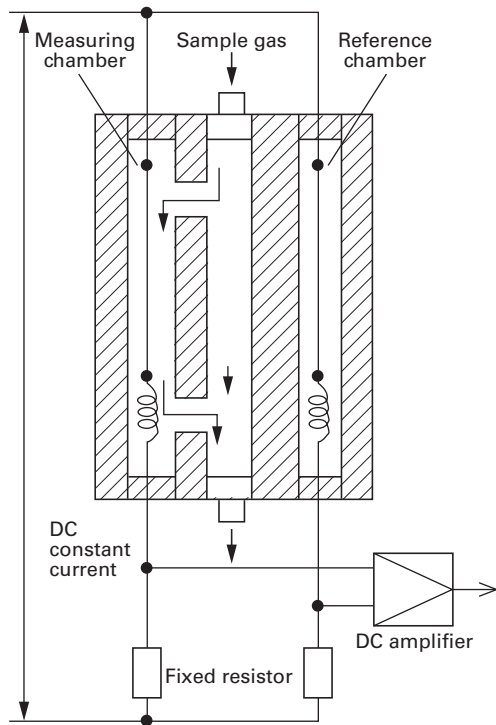

This thermal conductivity gas analyzer measures gas concentration by utilizing the different thermal conductivities of 2 gas components. In the detector, there are reference and measuring chambers in each of which a thin platinum wire is stretched. The reference chamber is filled with reference gas and through the measuring chamber, sample gas is flowed. Each platinum wire composes a bridge circuit in combination with an external fixed resistor, and it is heated by flowing a constant current. When there is a change in the concentration of the component under measurement, the thermal conductivity of sample gas will change to affect the temperature of the platinum wire in the measuring chamber. The resulting thermal change is taken out as a change in electric resistance, according to which the concentration of measured gas is calculated.

## Thermal Conductivity Ratio of Gases

Gases	Comparative thermal conductivity (0C) when replacing thermal conductivity of air ( $2.41 \times 10^{-2}$ w/(m.k) with 1
Sulfur dioxide gas SO <sub>2</sub>	0.5
Carbon dioxide gas CO <sub>2</sub>	0.7
Argon Ar	0.7
Carbon monoxide CO	0.7
Steam (100C) H <sub>2</sub> O	0.7
Air	1.0
Nitrogen N <sub>2</sub>	1.0
Oxygen O <sub>2</sub>	1.0
Methane CH <sub>4</sub>	1.5
Hydrogen H <sub>2</sub>	2.0

Table 1: Measurable Component and Measurable Range

Measured gas	Reference gas component (Note 1)	Measurable range	Range ratio(Note 2)
H <sub>2</sub>	N <sub>2</sub> , (CO <sub>2</sub> , Ar, He)	0 to 3, 5, 10, 20, 50, 80, 100% 100 to 90, 100 to 80%	1 : 10
He	N <sub>2</sub> , (CO <sub>2</sub> , Ar) O <sub>2</sub> , Air	0 to 5, 10, 20, 30, 40, 50, 80, 100% 100 to 90, 100 to 80%	1 : 10
Ar	N <sub>2</sub> , O <sub>2</sub> , Air, (He)	0 to 10, 20, 50, 80, 100% 100 to 90, 100 to 80%	1 : 5
CH <sub>4</sub>	N <sub>2</sub> , (CO <sub>2</sub> , Ar, He)	0 to 20, 40, 50, 60, 80, 100% 100 to 80%	1 : 5
CO <sub>2</sub>	N <sub>2</sub> , O <sub>2</sub> , Air, (He)	0 to 10, 20, 50, 100% 100 to 90, 80%	1 : 5

(Note 1) Contact us for the components in the parentheses. H<sub>2</sub> contained in O<sub>2</sub> cannot be measured.  
 (Note 2) Range ratio stands for maximum value.

## GAS SAMPLING SYSTEM DIAGRAM (EXAMPLE)

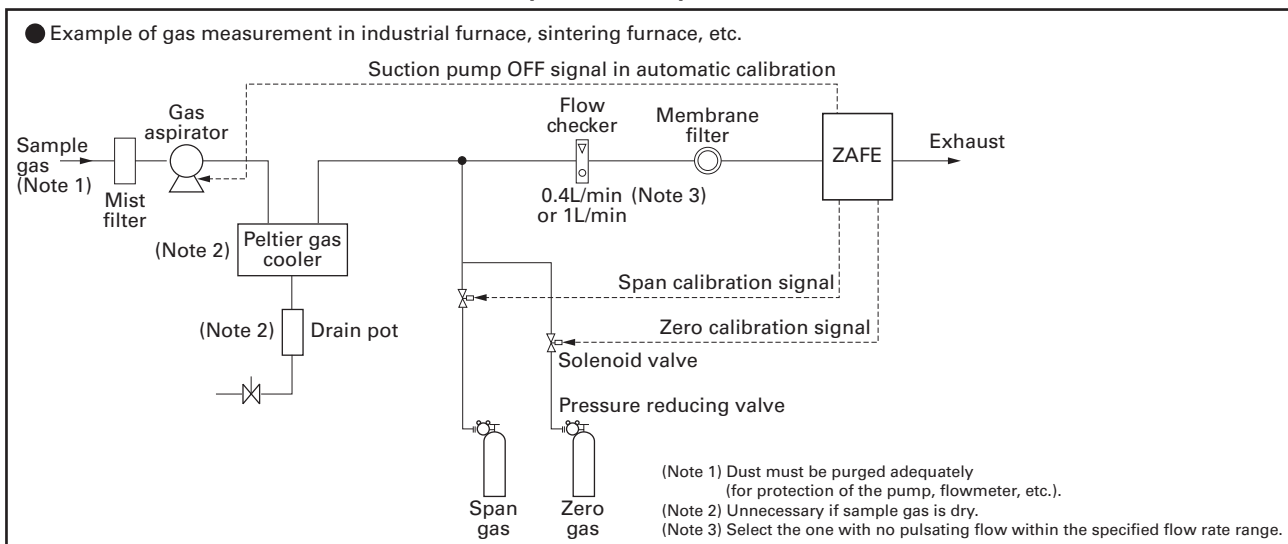

# CODE SYMBOLS

Digit	Description	4	5	6	7	8	9	10	11	12	13	14	15	16	17	18
4	<Construction> Hazardous location	E														
5	<Measured component> H <sub>2</sub> Ar He CH <sub>4</sub> CO <sub>2</sub> (reference gas Ar unallowable) Other	K L M E A Z														
6	<Reference gas> (Note 1) N <sub>2</sub> Air (incompatible with H <sub>2</sub> /CH <sub>4</sub> measurement) O <sub>2</sub> (incompatible with H <sub>2</sub> /CH <sub>4</sub> measurement) Other			4 5 6 Z												
7	<Connection port size> G1/2 Rc1/2 NPT1/2				A B C											
8	<Revision No.>					4										
9	<Measuring range (1st range)> 0 to 3% (H <sub>2</sub> ) 0 to 5% (H <sub>2</sub> , He) 0 to 10% (H <sub>2</sub> , He, Ar, CO <sub>2</sub> ) 0 to 20% 0 to 30% 0 to 50% 0 to 80% 0 to 100% 100 to 90% (H <sub>2</sub> , He, Ar) 100 to 80% (H <sub>2</sub> , He, Ar, CH <sub>4</sub> ) Other						Q L M N V P T J 9 8 Z									
10	<Measuring range (2nd range)> (Note 2) None 0 to 5% (H <sub>2</sub> , He) 0 to 10% (H <sub>2</sub> , He, Ar) 0 to 20% (H <sub>2</sub> , He, Ar, CO <sub>2</sub> ) 0 to 30% 0 to 50% 0 to 80% 0 to 100% Other						Y L M N V P T J Z									
11	<Measured value output> DC4 to 20 mA DC0 to 1V DC4 to 20 mA + RS-232C communication DC 0 to 1 V + RS-232C communication DC0 to 10mV							A B C D E								
12	—								A							
13	<H <sub>2</sub> meter interference corrective calculation> (Note 3) None Provided									Y A						
14	<Input/output contacts> None Automatic calibration Concentration alarm Contact output selection } See table below.											Y A C E				
15	<Indication> Japanese English Chinese												J E C			
16	<Response speed> Standard response High-speed response (Note 4)													A B		
17	<Number of cable gland> None 3 4 5 6 7 8														0 3 4 5 6 7 Z	
18	<Ex. Standard> NEPSI															N

(Note 1) Reference gas refers to gas other than the component to be measured in sample gas.

("Z" must be specified when interference gas is to be contained.)

(Note 2) The ratio of maximum range to the first range is as given below.

For CO<sub>2</sub>, Ar or CH<sub>4</sub> measurement : 1st range x 5 (times)

For He or H<sub>2</sub> measurement : 1st range x 10 (times) A range from 0 to ...% cannot be combined with that from 100 to ...%.

1st range < 2nd range

(Note 3) A CO<sub>2</sub> or CH<sub>4</sub> meter needs to be prepared separately.

A reverse range such as 100 to 0% cannot be specified.

Input signal is 1 to 5 V DC.

Adjustment is required at Fuji Electric's factory.

Details of measurement gas will be checked when receiving an order.

Reverse range such as 100% to 0% cannot be specified.

Cannot be specified if high-speed response is selected.

(Note 4) High-speed response is for H<sub>2</sub> meter used for reference gas N<sub>2</sub> only.

Input/output contact specifications		14th digit : A	14th digit : C	14th digit : E	
		Automatic calibration	Concentration alarm	Contact output selection (Note 7)	
Contact output	Automatic calibration	Zero gas valve drive Span gas valve drive Suction pump OFF in automatic calibration	○ (DO1) ○ (DO2) ● (DO3)	— — —	○ ○ ●
	Concentration alarm	Upper limit (1 point) concentration alarm Lower limit (1 point) concentration alarm Upper/lower limit (1 point as a set) concentration alarm Upper limit (1 point) and lower limit (1 point) concentration alarm 2-step upper limit (1 point each) concentration alarm 2-step lower limit (1 point each) concentration alarm	— — — — —	Any one alarm settable on screen (DO1, 2) 2 Point (NO) Contact	Any one alarm settable on screen 2 Point (NO) Contact
	Other	Calibration status Range information (2-range meter) (Note 3) Analyzer error or automatic calibration error	○ (DO4) — ○ (DO5)	○ (DO4) ○ (DO3) ○ (DO5)	○ ○ ○
Contact input		Remote automatic calibration start (Note 4) Remote range changeover (2-range meter) (Note 5) Remote measured value output holding (Note 6)	○ (DI3) ○ (DI2) ○ (DI1)	○ (DI3) ○ (DI2) ○ (DI1)	○ (DI3) ○ (DI2) ○ (DI1)

(Note 1) Mark ○: Normally Open (NO) contact  
 (Note 2) Mark ●: Normally Closed (NC) contact, after turning on power supply  
 (Note 3) Low range : Contacts close, High range : Contacts open  
 (Note 4) When contacts open 1.5 sec after their closure, automatic calibration starts.  
 (Note 5) Contacts closed : Low range, Contacts open : High range  
 (Note 6) Contacts closed : Holding, Contacts open : Holding canceled  
 (Note 7) Up to 5 contact output points can be selected.

## SCOPE OF DELIVERY

Analyzer main unit  
 2 power fuses (250 V AC, 1 A)  
 Opner × 1  
 Wrench × 1  
 Instruction Manual

## ITEMS TO BE PREPARED SEPARATELY

Gas sampling equipment, standard gas, receiving instrument, etc.  
 With interference corrective calculation: CH<sub>4</sub> or CO<sub>2</sub> gas analyzer

## ORDERING INFORMATION

1. Analyzer type
2. Gas component to be measured
3. Measuring range
4. Gas component other than measured  
 Very important information required to achieve intended accuracy of the instrument.  
 (Enter in "Table for checking sample gas component" on the next page.)

# OUTLINE DIAGRAM (Unit : mm)

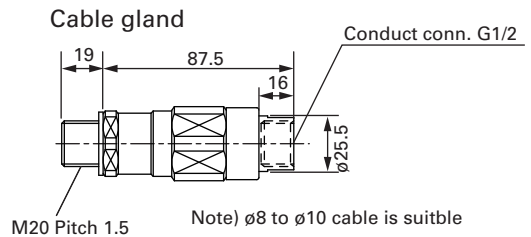
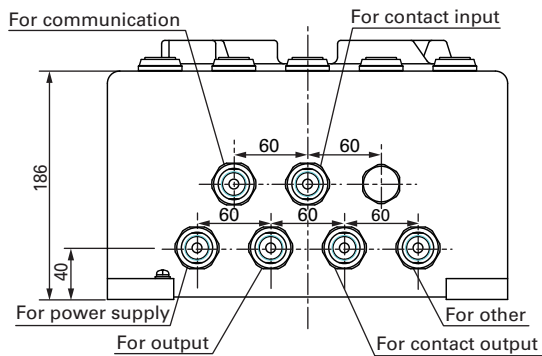
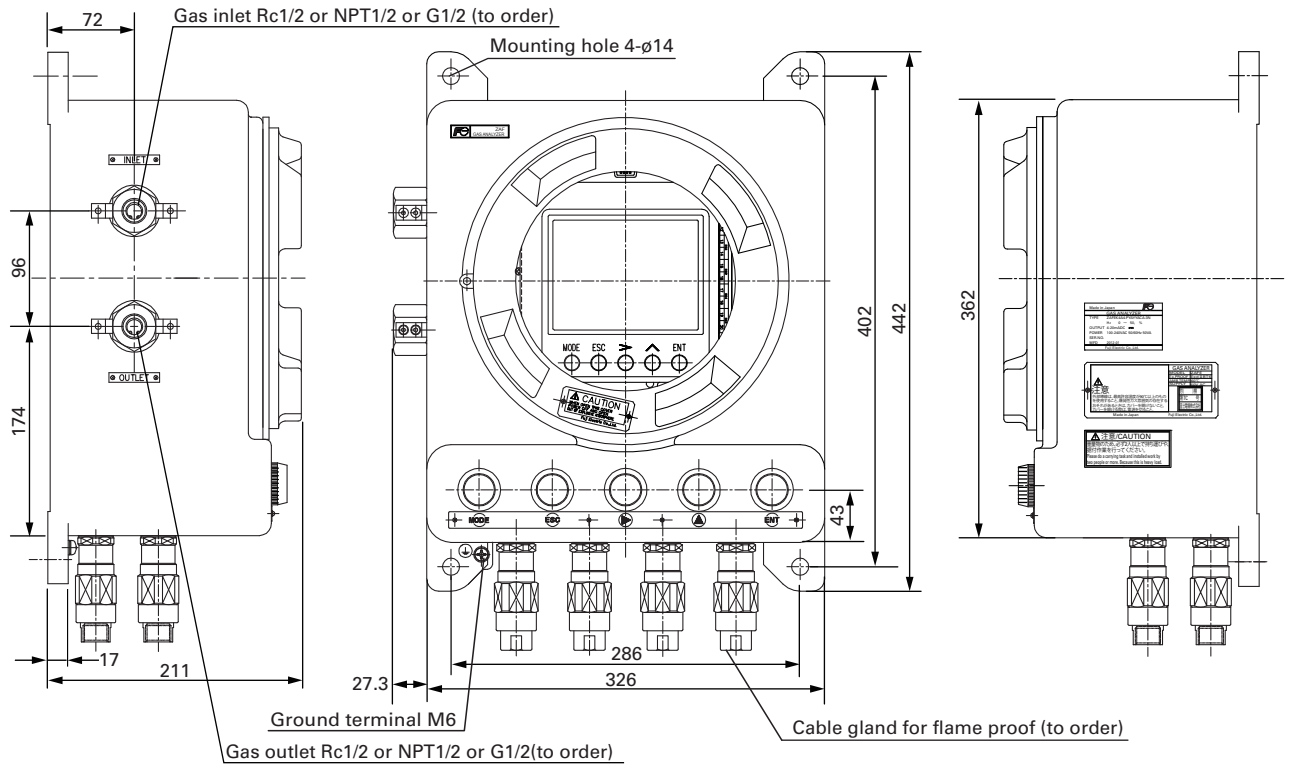

# CONNECTION DIAGRAM

(Standard)

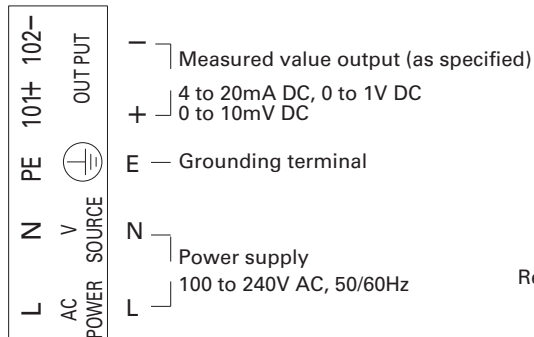

(M3.5 screw)

(Option) 13th digit A and 14th digit A, C, E

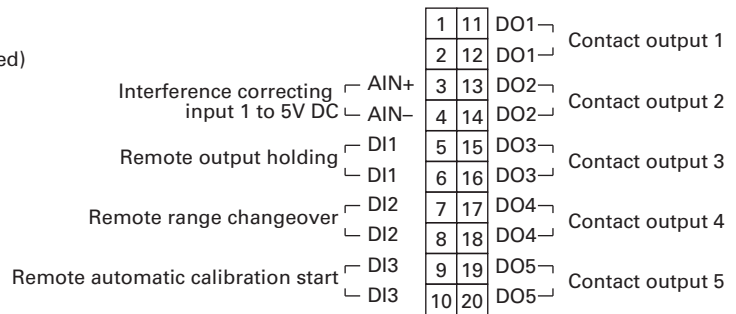

(M3.5 screw)

Refer to "Input/output contact specifications" in CODE SYMBOLS.

## RS-232C communication (option)

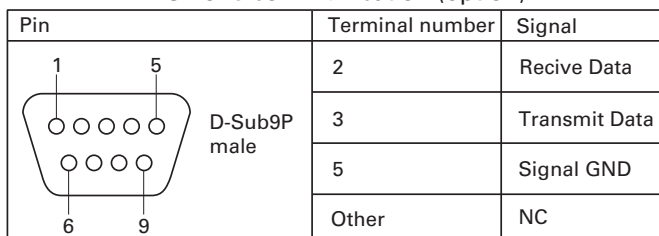

## <Table for checking sample gas component of thermal conductivity gas analyzer (ZAFE)>

Let us check your sample gas for safe use of Fuji Electric' gas analyzer.  
 Make entries where you can answer. If there is any question, contact our salesperson in charge of your company.  
 The analyzer may not provide full performance depending on other gas components contained in sample gas.

Date

Item	Description
Name of customer at delivery destination	
Application, purpose	
Gas component to be measured	

Sample gas		Minimum concentration (%)	Normal concentration (%)	Maximum concentration (%)	Remarks
Component to be measured					
Other component gas					
Other component gas					

Interference gas input	Measuring range	CO <sub>2</sub> meter or CH <sub>4</sub> meter
	0-	

Your question, etc.	
---------------------	--

Customer information	Company name
	Section
	Address
	TEL
	Person in charge

Fuji Electric's salesperson in charge of your company \_\_\_\_\_

⚠ Caution on Safety

\*Before using this product, be sure to read its instruction manual.



**Global Sales Section**  
**Instrumentation & Sensors Planning Dept.**  
 1, Fuji-machi, Hino-city, Tokyo 191-8502, Japan  
<http://www.fujielectric.com>  
 Phone: +81-42-514-8930 Fax: +81-42-583-8275  
<http://www.fujielectric.com/products/instruments/>